



GENERAL CATALOGUE

 **PEDROLLO**[®]
... the spring of life



PEDROLLO S.p.A.

Via Enrico Fermi 7

37047 San Bonifacio (Verona) ITALY

paid-up capital € 40.000.000,00

Tel. +39 045 6136311

Fax +39 045 7614663

e-mail: sales@pedrollo.com

www.pedrollo.com

Index

PERIPHERAL



CENTRIFUGAL



MULTI-STAGE



SELF-PRIMING



BRONZE PERIPHERAL



STAINLESS STEEL PERIPHERAL



STANDARDIZED CENTRIFUGAL



PORTABLE



SUBMERSIBLE MULTI-STAGE



VERTICAL MULTI-STAGE



SUBMERSIBLE MULTI-STAGE



VERTICAL MULTI-STAGE



4" SUBMERSIBLE PERIPHERAL

4SK  **214**

4" SUBMERSIBLE MONOBLOCK

4BLOCK  **218**

4" SUBMERSIBLE

4SR  **222**

6" SUBMERSIBLE

6SR  **238**

4" - 6" MOTORS

4PD  **250**

6PD  **254**

SUBMERSIBLE

TOP  **256**

RX  **278**

SUBMERSIBLE

VX-I  **290**

MC-I  **294**

ZD  **298**

ZX  **302**

D  **306**

DC  **310**

VX  **314**

MC  **318**

VX-F  **322**

MC-F  **326**

VXC  **330**

MC  **338**

PVXC **346**

PMC **350**

SAR

 **354**

EASYPRESS

 **364**

 **366**

EASYPUMP

 **368**

PR

 **369**

HYDROFRESH

 **370**

COMBIPRESS "CB2"

 **374**

Km1

 **380**

DHL CIRCULATORS

 **382**

ACCESSORIES

384

Pedrollo S.p.A. was founded in 1974. Having grown over the years to assume an international character, the company is now recognised as one of the world leaders in the domestic pump sector.

Currently the company covers an area of 80.000 m² and is characterised by its highly automated production process.

The constant quality control of the entire production cycle and the use of the most advanced technological solutions available guarantees that the products are of an extremely high quality.

Thanks to the use of the most sophisticated robots and advanced production lines available, the company is capable of producing over 2.000.000 pumps a year from a range covering over 100 different families of pumps.







Pedrollo pumps are sold in over 160 countries worldwide via a sales network capable of offering its clients the choice from a vast range of products suitable for most domestic, civil, agricultural and industrial applications.

An international sales team, composed of professionals from various parts of the world, ensures that the client is able to count on an extremely high level of service and personalised advice regarding the best solution to adopt.

The research and design department is equipped with the most advanced hardware and software available.

A modern laboratory where hydraulic tests take place, workstations where fluid-dynamic and finite element analysis is carried out, together with creativity and passion, all combine to produce new pumps and to continually improve the existing range with particular attention being paid to sturdiness and low energy consumption, thus providing each and every client with a simple and reliable product capable of providing surprising levels of performance.







All major components are manufactured 'in house' by Pedrollo.
Starting with raw materials, the foundry, machine shop, sheet metal works and motor winding facilities, under the guidance of our QA Inspectors, produce high quality precision components at all times.



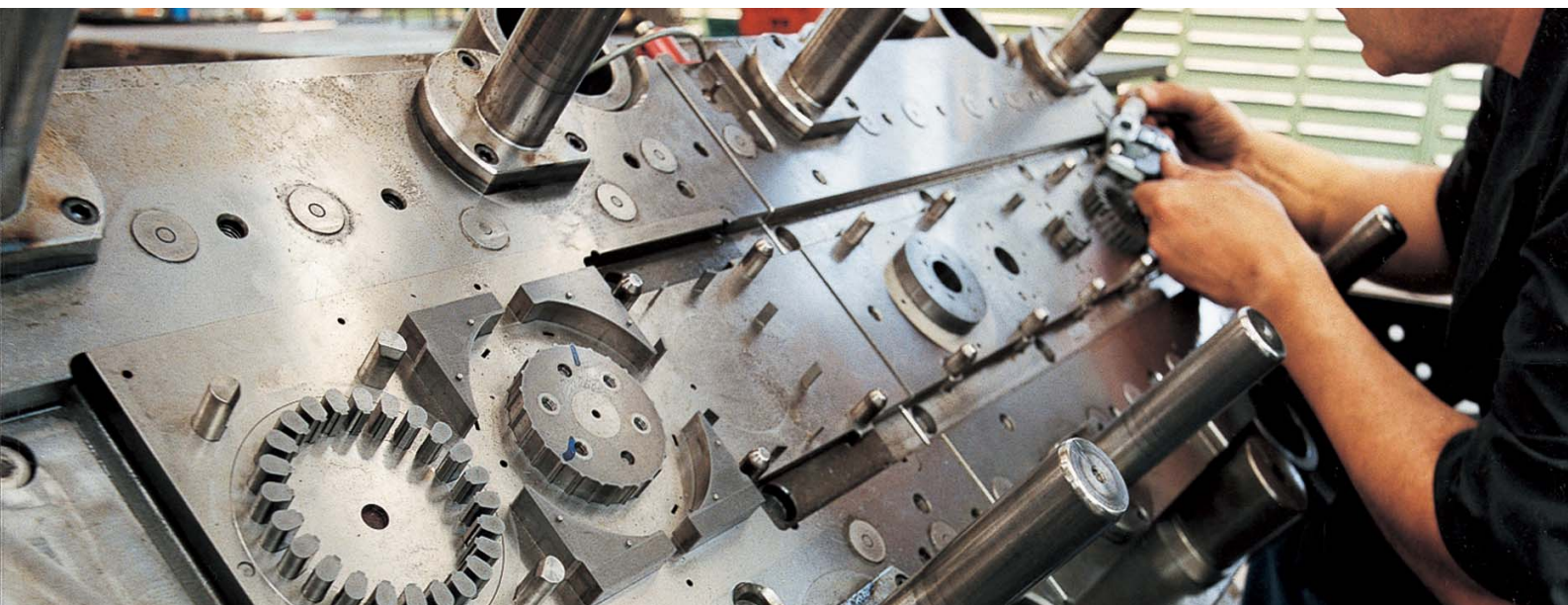
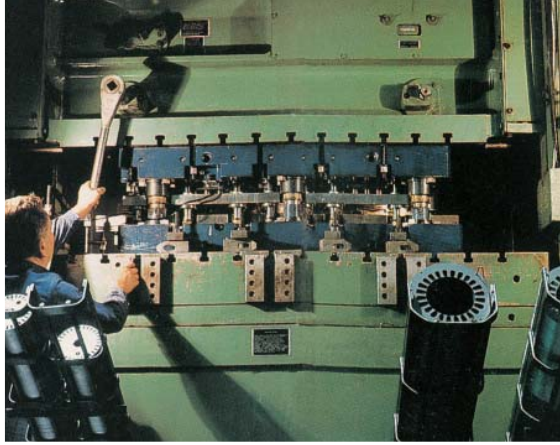





The final assembly of our pumps takes place on automated assembly lines, capable of providing a high assembly quality while carrying out automated tests at the same time, thus ensuring that the final product is produced in the shortest time possible.







Before approval is given for the production of a new pump, all new models are tested in our laboratory.

Fitted with a rig capable of reproducing the most strenuous of working conditions, the laboratory allows us to test the success of the design process.

 **PEDROLLO**[®]
... the spring of life





PERFORMANCE RANGE

- Flow rate up to **90 l/min** (5.4 m³/h)
- Head up to **100 m**

APPLICATION LIMITS

- Manometric suction lift up to **8 m**
- Liquid temperature between **-10 °C** and **+60 °C**
- Ambient temperature up to **+40 °C**
- Max. working pressure:
 - **6.5 bar** for PK 60-65-70-80
 - **10 bar** for PK 90-100-200-300
- Continuous service **S1**

CONSTRUCTION AND SAFETY STANDARDS

EN 60335-1
IEC 60335-1
CEI 61-150

EN 60034-1
IEC 60034-1
CEI 2-3



CERTIFICATIONS



INSTALLATION AND USE

Suitable for use with clean water that does not contain abrasive particles and liquids that are not chemically aggressive towards the materials from which the pump is made.

Thanks to their reliability, the fact that they are easy to use and are economical, they are ideal for domestic use and in particular for distributing water in combination with small pressure sets and for the irrigation of gardens and allotments.

The pump should be installed in an enclosed environment, or at least sheltered from inclement weather.

PATENTS - TRADE MARKS - MODELS

- Motor bracket: patent n° IT1243605 (reduces the risk of the impeller locking after long periods of inactivity)
- PKm 60° is a registered trade mark
- Registered Italian model n° 72753

OPTIONALS AVAILABLE ON REQUEST

- Special mechanical seal
- Other voltages or 60 Hz frequency
- IP55 class protection

GUARANTEE

1 year subject to terms and conditions

CHARACTERISTIC CURVES AND PERFORMANCE DATA

50 Hz n= 2900 1/min HS= 0 m

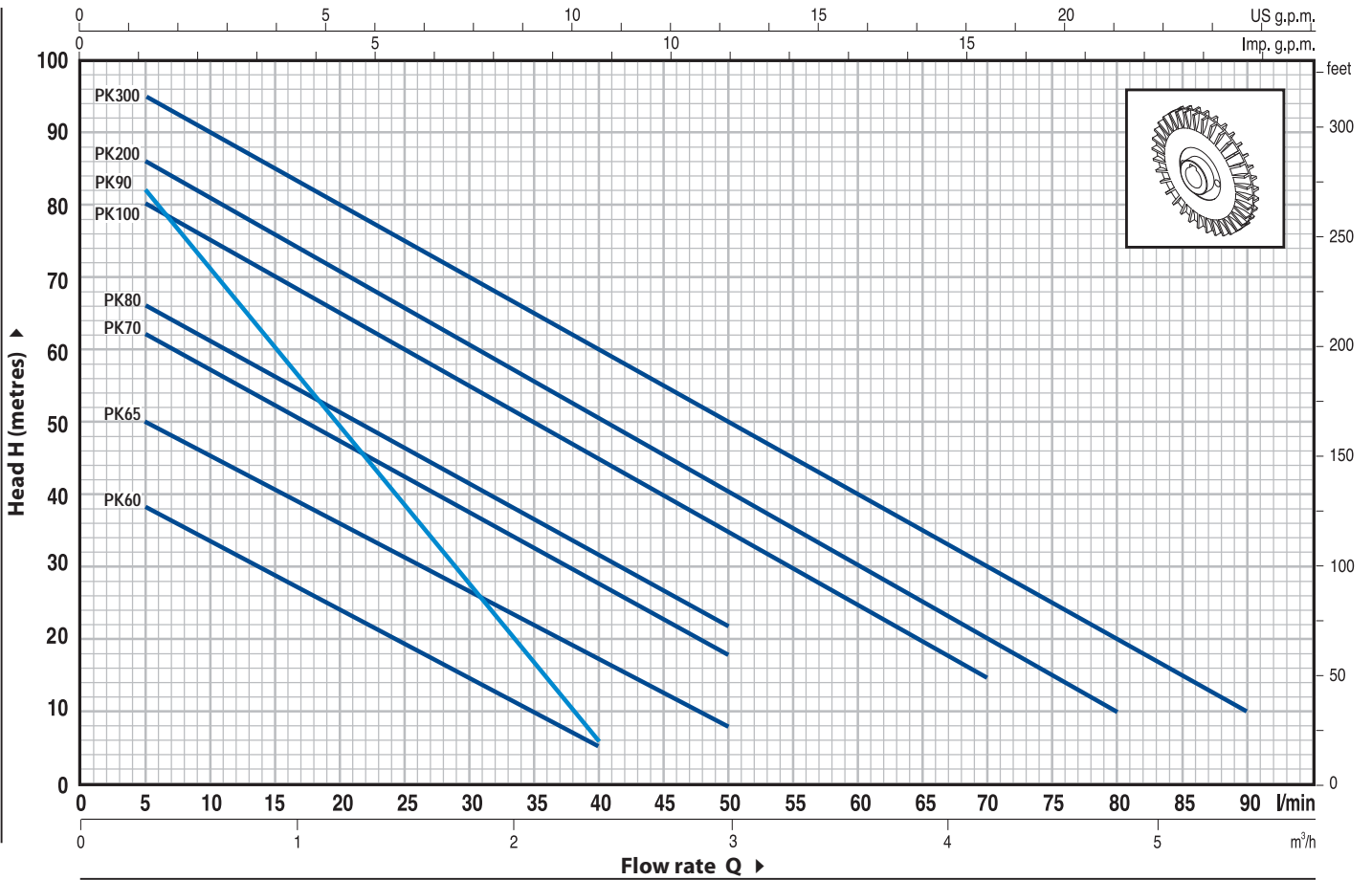

MODEL		POWER		Q	Flow rate																
Single-phase	Three-phase	kW	HP		m³/h	0	0.3	0.6	0.9	1.2	1.5	1.8	2.1	2.4	3.0	3.6	4.2	4.8	5.4		
				l/min	0	5	10	15	20	25	30	35	40	50	60	70	80	90			
	PKm 60®	PK 60®	0.37	0.50	H metres	40	38	33.5	29	24	19.5	15	10	5							
	PKm 65	PK 65	0.50	0.70		55	50	45.5	40.5	36	31	27	22	17	8						
	PKm 70	PK 70	0.60	0.85		65	62	57	52	47	42	37	32	27	18						
	PKm 80	PK 80	0.75	1		70	66	61	56	51	46	41	36.5	31	22						
	PKm 90	PK 90	0.75	1		90	82	71	60	49	38	27	17	5							
	PKm 100	PK 100	1.1	1.5		85	80	75	70	65	60	55	50	45	35	25	15				
	PKm 200	PK 200	1.5	2		90	86	81	76	71	65.5	60	55	50	40	30	20	10			
	-	PK 300	2.2	3		100	95	90	85	80	75	70	65	60	50	40	30	20	10		

Q = Flow rate H = Total manometric head HS = Suction height

Tolerance of characteristic curves in compliance with EN ISO 9906 App. A.

POS.	COMPONENT	CONSTRUCTION CHARACTERISTICS						
1	PUMP BODY	Cast iron, complete with threaded ports in compliance with ISO 228/1						
2	MOTOR BRACKET	Aluminium with brass insert (patented), reduces the risk of impeller seizure						
3	IMPELLER	Brass, with peripheral radial vanes						
4	MOTOR SHAFT	Stainless steel EN 10088-3 - 1.4104						
5	MECHANICAL SEAL	Pump	Seal	Shaft	Materials			
		<i>Model</i>	<i>Model</i>	<i>Diameter</i>	<i>Stationary ring</i>	<i>Rotational ring</i>	<i>Elastomer</i>	
		PK 60-65-70-80	AR-12	Ø 12 mm	Ceramic	Graphite	NBR	
		PK 90	FN-12	Ø 12 mm	Ceramic	Graphite	NBR	
	PK 100-200-300	FN-14	Ø 14 mm	Graphite	Ceramic	NBR		
6	BEARINGS	Pump	Model					
		PK 60-65	6201 ZZ / 6201 ZZ					
		PK 70-80-90	6203 ZZ / 6203 ZZ					
		PK 100-200-300	6204 ZZ / 6204 ZZ					
7	CAPACITOR	Pump	Capacitance					
		<i>Single-phase</i>	<i>(230 V or 240 V)</i>		<i>(110 V)</i>			
		PKm 60	10 µF 450 VL	25 µF 250 VL				
		PKm 65	14 µF 450 VL	30 µF 250 VL				
		PKm 70	16 µF 450 VL	60 µF 300 VL				
		PKm 80	20 µF 450 VL	60 µF 300 VL				
		PKm 90	20 µF 450 VL	60 µF 300 VL				
		PKm 100	31.5 µF 450 VL	60 µF 250 VL				
	PKm 200	45 µF 450 VL	80 µF 250 VL					
8	ELECTRIC MOTOR	PKm: single-phase 230 V - 50 Hz with thermal overload protector built-in to the winding. PK: three-phase 230/400 V - 50 Hz. ⇒ Pumps fitted with the three-phase motor option offer IE2 (IEC 60034-30) class high performance – Insulation: F class. – Protection: IP 44.						

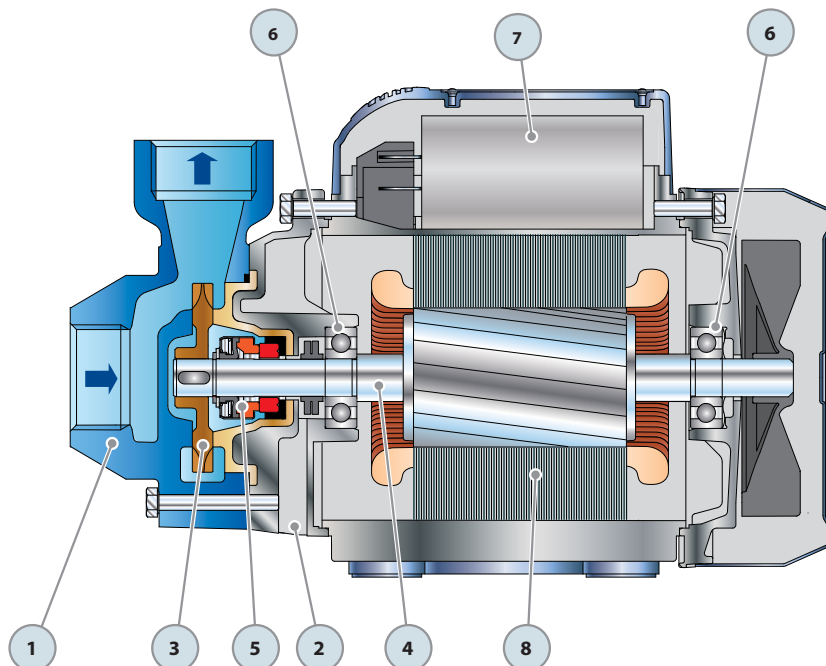

DIMENSIONS AND WEIGHT

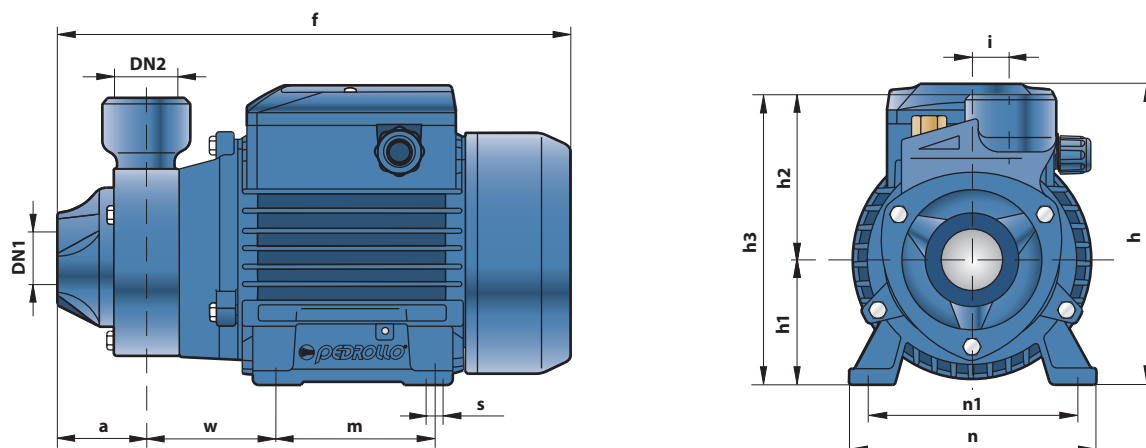

MODEL		PORTS		DIMENSIONS mm												kg	
Single-phase	Three-phase	DN1	DN2	a	f	h	h1	h2	h3	i	m	n	n1	w	s	1~	3~
PKm 60°	PK 60°	1"	1"	42	245	152	63	75	138	20	80	120	100	55	7	5.3	5.3
PKm 65	PK 65			55	285	180	71	80	143							6.9	6.4
PKm 70	PK 70			55	285	180	71	85	156							10.1	9.0
PKm 80	PK 80			55	285	180	71	85	156							10.1	9.0
PKm 90	PK 90	3/4"	3/4"	58	282			95	166							10.2	9.2
PKm 100	PK 100	1"	1"	55	350	212	80	94	174		100	164	125	85	9	14.4	12.4
PKm 200	PK 200															15.5	13.4
-	PK 300															-	15.6

ABSORPTION

MODEL	VOLTAGE (single-phase)		
	230 V	240 V	110 V
Single-phase			
PKm 60°	2.5 A	2.4 A	5.5 A
PKm 65	3.7 A	3.4 A	7.4 A
PKm 70	5.2 A	4.8 A	10.8 A
PKm 80	5.2 A	4.8 A	10.8 A
PKm 90	5.6 A	5.1 A	11.5 A
PKm 100	9.0 A	8.2 A	18.0 A
PKm 200	11.5 A	11.0 A	24.0 A

MODEL	VOLTAGE (three-phase)				
	230 V	400 V	690 V	240 V	415 V
Three-phase					
PK 60°	2.0 A	1.15 A	-	1.9 A	1.1 A
PK 65	3.0 A	1.7 A	-	2.8 A	1.6 A
PK 70	3.8 A	2.2 A	-	3.3 A	1.9 A
PK 80	3.8 A	2.2 A	-	3.3 A	1.9 A
PK 90	4.0 A	2.3 A	-	3.8 A	2.2 A
PK 100	6.2 A	3.6 A	2.05 A	5.7 A	3.3 A
PK 200	7.6 A	4.4 A	2.5 A	7.0 A	4.0 A
PK 300	9.3 A	5.4 A	3.15 A	8.7 A	5.0 A

PALLETIZATION

MODEL		GROUPAGE				CONTAINER			
Single-phase	Three-phase	n° pumps	H (mm)	kg		n° pumps	H (mm)	kg	
				1~	3~			1~	3~
PKm 60°	PK 60°	216	1420	1170	1170	324	2050	1740	1740
PKm 65	PK 65	216	1440	1510	1400	243	1600	1700	1580
PKm 70	PK 70	120	1300	1230	1100	180	1870	1840	1640
PKm 80	PK 80	120	1300	1230	1100	180	1870	1840	1640
PKm 90	PK 90	120	1300	1250	1130	180	1870	1860	1680
PKm 100	PK 100	72	1520	1060	910	84	1750	1230	1060
PKm 200	PK 200	72	1520	1140	990	84	1750	1320	1150
-	PK 300	72	1520	-	1140	84	1750	-	1330

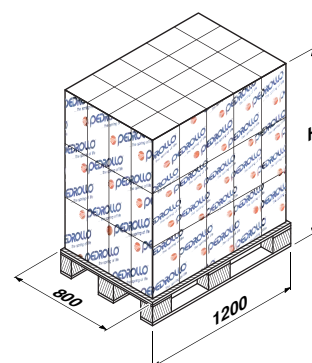



PERFORMANCE RANGE

- Flow rate up to **50 l/min** (3 m³/h)
- Head up to **70 m**

APPLICATION LIMITS

- Manometric suction lift up to **9 m** (HS)
- Liquid temperature between **-10 °C** and **+60 °C**
- Ambient temperature up to **+40 °C**
- Max. working pressure **6.5 bar**
- Continuous service **S1**

CONSTRUCTION AND SAFETY STANDARDS

EN 60335-1
IEC 60335-1
CEI 61-150

EN 60034-1
IEC 60034-1
CEI 2-3



CERTIFICATIONS



INSTALLATION AND USE

Suitable for use with clean water that does not contain abrasive particles and liquids that are not chemically aggressive towards the materials from which the pump is made.

As a result of their compactness, reliability and the fact that they are easy to use, they are suitable for use in domestic applications such as the distribution of water in combination with small pressure sets, for the irrigation of gardens and allotments, for drawing water from tanks and for all those other situations where air or water may be present in the water to be pumped. The pump comes complete with a flap-check valve.

The pump should be installed in an enclosed environment, or at least sheltered from inclement weather.

PATENTS - TRADE MARKS - MODELS

- Motor bracket: patent n° IT1243605
- Registered Italian model n° 72753

OPTIONALS AVAILABLE ON REQUEST

- Special mechanical seal
- Other voltages or 60 Hz frequency
- IP55 class protection

GUARANTEE

1 year subject to terms and conditions

CHARACTERISTIC CURVES AND PERFORMANCE DATA

50 Hz n= 2900 1/min HS= 0 m

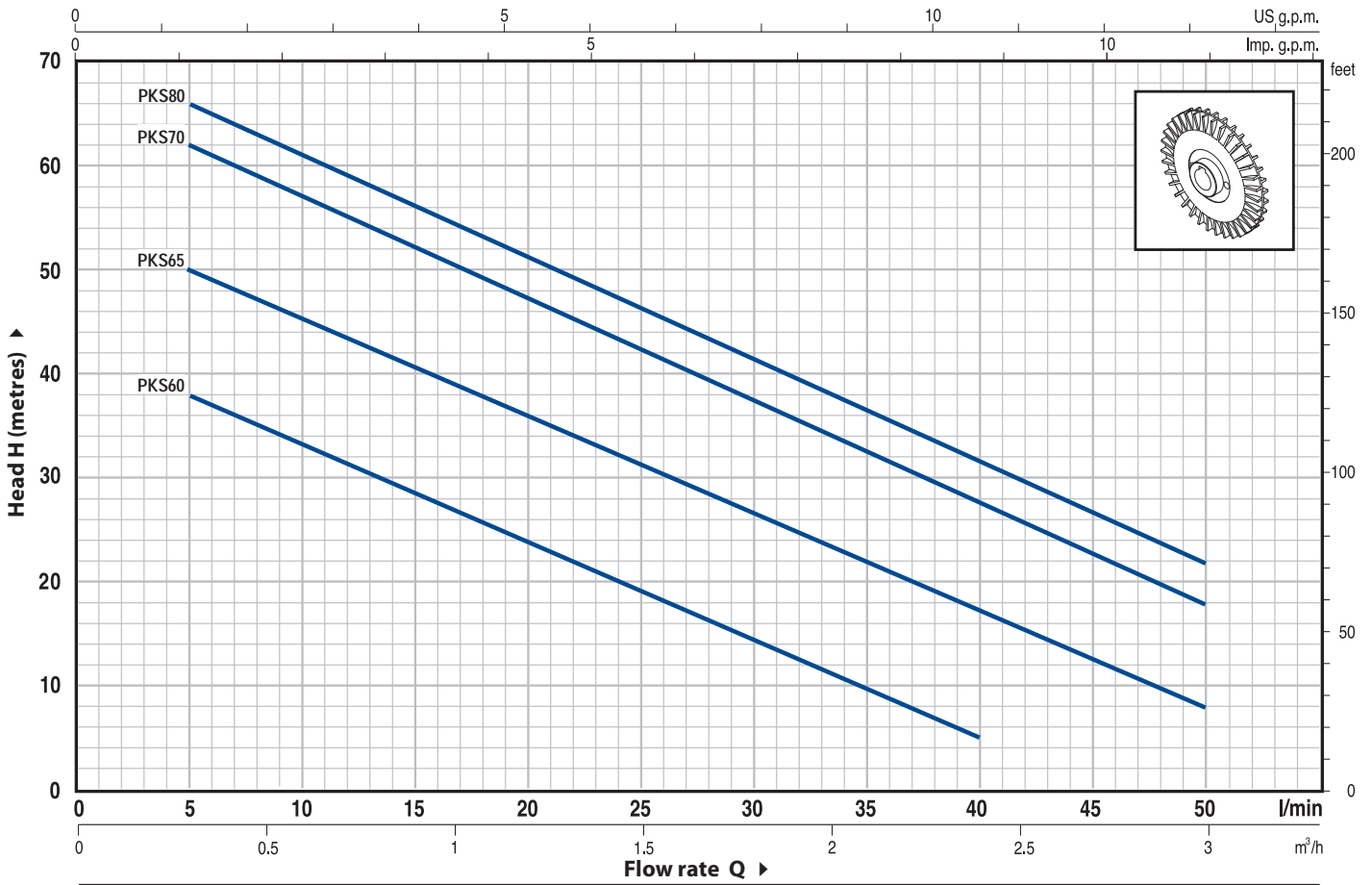

MODEL		POWER		Q	Flow rate														
Single-phase	Three-phase	kW	HP		m³/h	0	0.3	0.6	0.9	1.2	1.5	1.8	2.1	2.4	2.7	3.0			
				l/min	0	5	10	15	20	25	30	35	40	45	50				
PKSm 60	PKS 60	0.37	0.50	H metres	40	38	33.5	29	24	19.5	15	10	5						
PKSm 65	PKS 65	0.50	0.70		55	50	45.5	40.5	36	31	27	22	17	12.5	8				
PKSm 70	PKS 70	0.60	0.85		65	62	57	52	47	42	37	32	27	22	18				
PKSm 80	PKS 80	0.75	1		70	66	61	56	51	46	41	36.5	31	27	22				

Q = Flow rate H = Total manometric head HS = Suction height

Tolerance of characteristic curves in compliance with EN ISO 9906 App. A.

INSTALLATION EXAMPLE

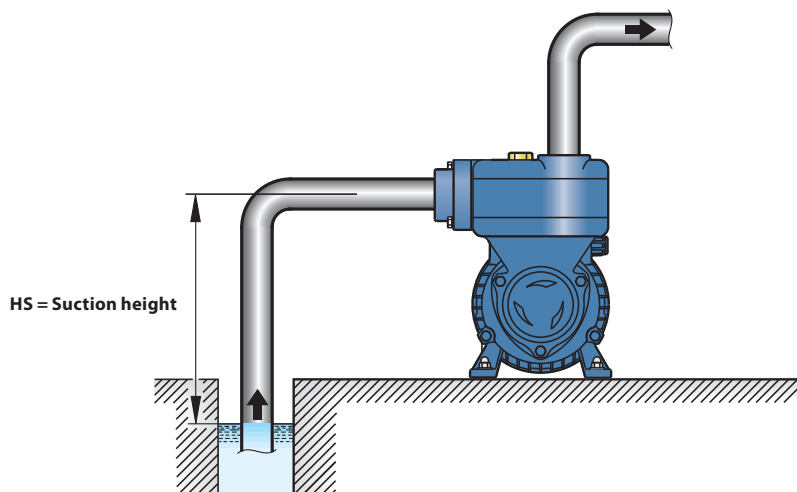

POS.	COMPONENT	CONSTRUCTION CHARACTERISTICS				
1	PUMP BODY	Cast iron, complete with threaded ports in compliance with ISO 228/1 and the suction port with built-in flap-check valve				
2	MOTOR BRACKET	Aluminium with brass insert (patented), reduces the risk of impeller seizure				
3	IMPELLER	Brass, with peripheral radial vanes				
4	MOTOR SHAFT	Stainless steel EN 10088-3 - 1.4104				
5	MECHANICAL SEAL	<i>Seal</i>	<i>Shaft</i>	<i>Materials</i>		
		<i>Model</i>	<i>Diameter</i>	<i>Stationary ring</i>	<i>Rotational ring</i>	<i>Elastomer</i>
		AR-12	Ø 12 mm	Ceramic	Graphite	NBR
6	BEARINGS	<i>Pump</i>	<i>Model</i>			
		PKS 60-65	6201 ZZ / 6201 ZZ			
		PKS 70-80	6203 ZZ / 6203 ZZ			
7	CAPACITOR	<i>Pump</i>	<i>Capacitance</i>			
		<i>Single-phase</i>	<i>(230 V or 240 V)</i>	<i>(110 V)</i>		
		PKSm 60	10 µF 450 VL	25 µF 250 VL		
		PKSm 60	14 µF 450 VL	30 µF 250 VL		
		PKSm 70	16 µF 450 VL	60 µF 250 VL		
		PKSm 80	20 µF 450 VL	60 µF 250 VL		
8	ELECTRIC MOTOR	<p>PKSm: single-phase 230 V - 50 Hz with thermal overload protector built-in to the winding.</p> <p>PKS: three-phase 230/400 V - 50 Hz.</p> <p>⇒ Pumps fitted with the three-phase motor option offer IE2 (IEC 60034-30) class high performance</p> <p>– Insulation: F class.</p> <p>– Protection: IP 44.</p>				

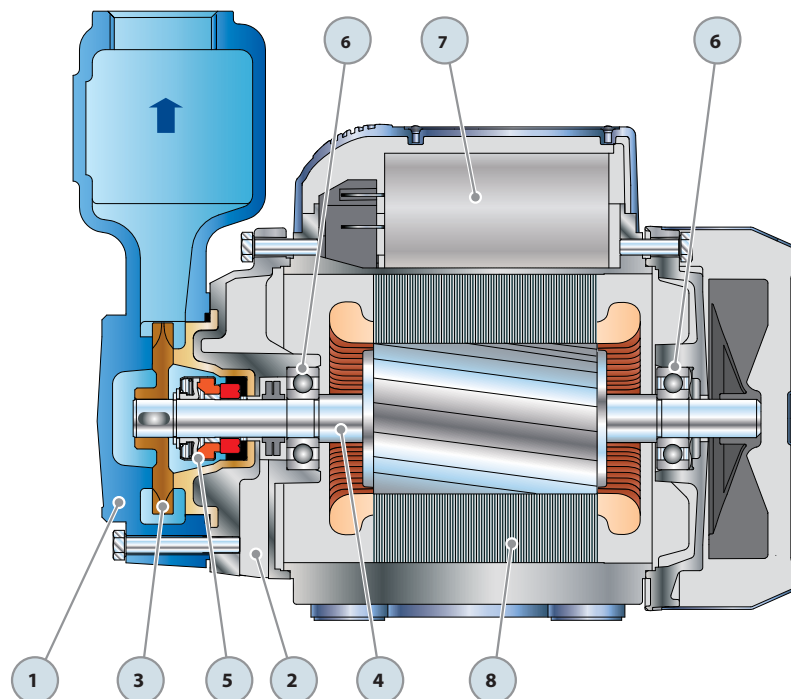

DIMENSIONS AND WEIGHT

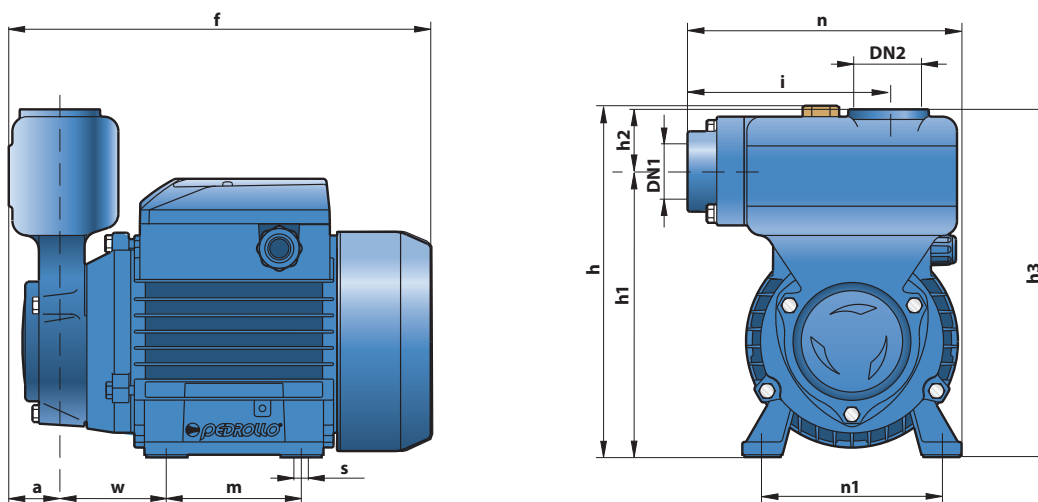

MODEL		PORTS		DIMENSIONS mm												kg	
Single-phase	Three-phase	DN1	DN2	a	f	h	h1	h2	h3	i	m	n	n1	w	s	1~	3~
PKSm 60	PKS 60	1"	1"	29	230	192	156	34	190	110	80	150	100	55	7	6.0	6.0
PKSm 65	PKS 65				260	200	164		198		90	160	112	62		7.5	7.0
PKSm 70	PKS 70				260	200	164		198		90	160	112	62		10.6	9.7
PKSm 80	PKS 80				260	200	164		198		90	160	112	62		10.6	9.7

ABSORPTION

MODEL	VOLTAGE (single-phase)		
	230 V	240 V	110 V
Single-phase	230 V	240 V	110 V
PKSm 60	2.5 A	2.4 A	5.5 A
PKSm 65	3.7 A	3.4 A	7.4 A
PKSm 70	5.2 A	4.8 A	10.8 A
PKSm 80	5.2 A	4.8 A	10.8 A

MODEL	VOLTAGE (three-phase)			
	230 V	400 V	240 V	415 V
Three-phase	230 V	400 V	240 V	415 V
PKS 60	2.0 A	1.15 A	1.9 A	1.1 A
PKS 65	3.0 A	1.7 A	2.8 A	1.6 A
PKS 70	3.8 A	2.2 A	3.3 A	1.9 A
PKS 80	3.8 A	2.2 A	3.3 A	1.9 A

PALLETIZATION

MODEL		GROUPAGE				CONTAINER			
Single-phase	Three-phase	n° pumps	H (mm)	kg		n° pumps	H (mm)	kg	
				1~	3~			1~	3~
PKSm 60	PKS 60	189	1570	1155	1155	243	1970	1480	1480
PKSm 65	PKS 65	189	1570	1440	1340	243	1970	1840	1720
PKSm 70	PKS 70	105	1300	1130	1040	168	1980	1800	1650
PKSm 80	PKS 80	105	1300	1130	1040	168	1980	1800	1650

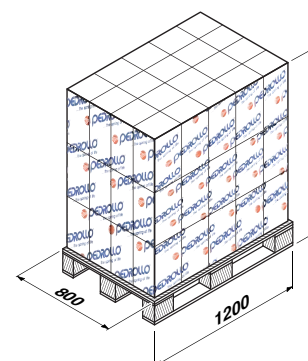



PERFORMANCE RANGE

- Flow rate up to **90 l/min** (5.4 m³/h)
- Head up to **100 m**

APPLICATION LIMITS

- Manometric suction lift up to **8 m**
- Liquid temperature between **-10 °C** and **+90 °C**
- Ambient temperature between **-10 °C** and **+40 °C**
- Max. working pressure:
 - **6 bar** for PQ 60-65
 - **10 bar** for PQ 70-80-81-90-100-200-300
- Continuous service **S1**

CONSTRUCTION AND SAFETY STANDARDS

EN 60034-1
IEC 60034-1
CEI 2-3



CERTIFICATIONS



INSTALLATION AND USE

Suitable for use with clean water that does not contain abrasive particles and liquids that are not chemically aggressive towards the materials from which the pump is made.

The hydraulic characteristics of these pumps, coupled with their compactness, makes them suitable for use in both domestic and industrial applications.

The pump should be installed in an enclosed environment, or at least sheltered from inclement weather.

PATENTS - TRADE MARKS - MODELS

- Motor bracket: patent n° IT1243605
- Registered Italian model n° 72753

OPTIONALS AVAILABLE ON REQUEST

- Special mechanical seal
- EN 10088-3 - 1.4401 (AISI 316) stainless steel motor shaft
- Other voltages or 60 Hz frequency
- IP55 class protection

GUARANTEE

1 year subject to terms and conditions

CHARACTERISTIC CURVES AND PERFORMANCE DATA

50 Hz n= 2900 1/min HS= 0 m

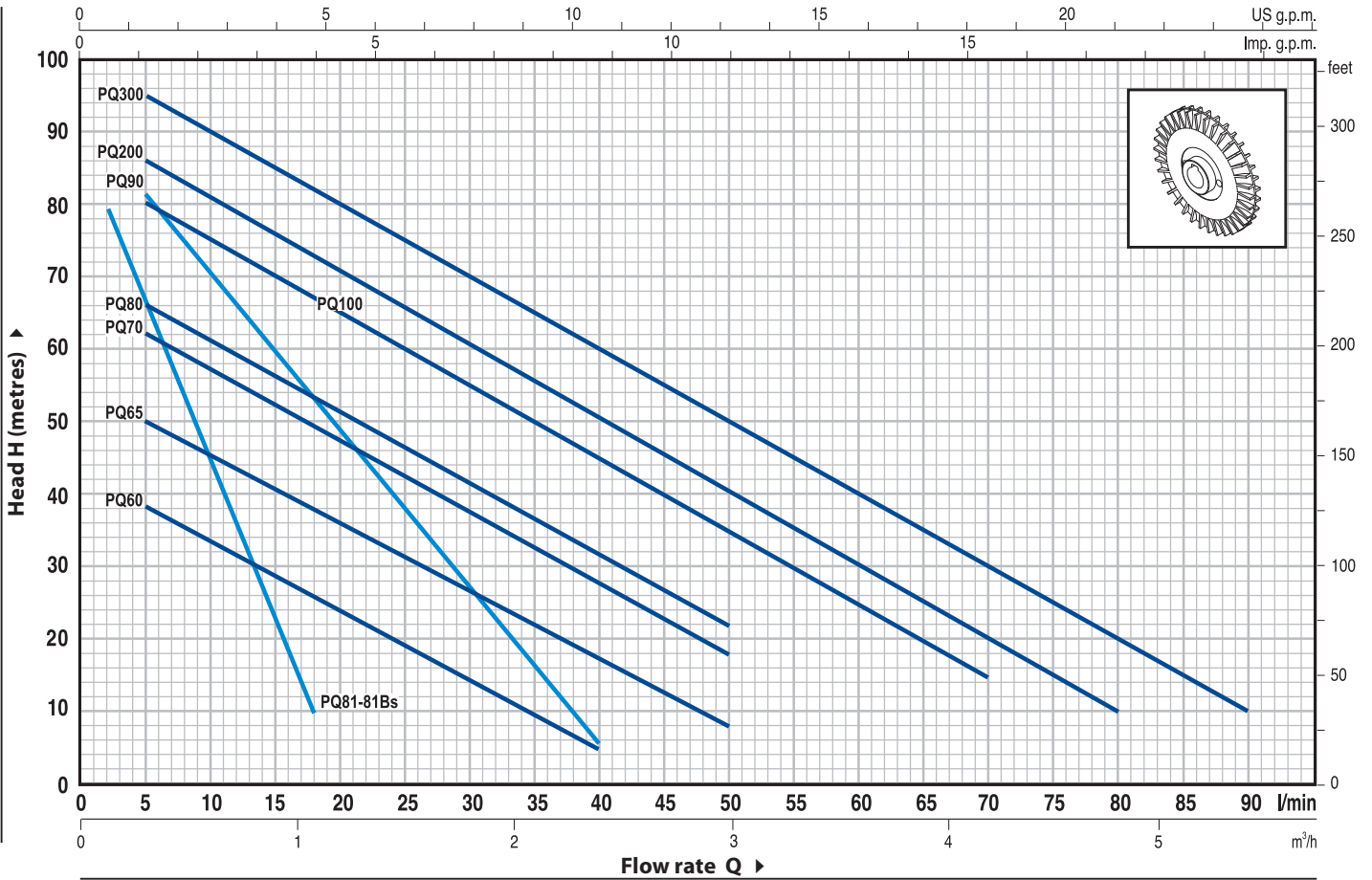

MODEL		POWER		Q	Flow rate																
Single-phase	Three-phase	kW	HP		m³/h	0	0.3	0.6	0.9	1.2	1.5	1.8	2.1	2.4	3.0	3.6	4.2	4.8	5.4		
				l/min	0	5	10	15	20	25	30	35	40	50	60	70	80	90			
PQm 60	PQ 60	0.37	0.50	H metres	40	38	33.5	29	24	19.5	15	10	5								
PQm 65	PQ 65	0.50	0.70		55	50	45.5	40.5	36	31	27	22	17	8							
PQm 70	PQ 70	0.60	0.85		65	62	57	52	47	42	37	32	27	18							
PQm 80	PQ 80	0.75	1		70	66	61	56	51	46	41	36.5	31	22							
PQm 90	PQ 90	0.75	1		90	82	71	60	49	38	27	17	5								
PQm 100	PQ 100	1.1	1.5		85	80	75	70	65	60	55	50	45	35	25	15					
PQm 200	PQ 200	1.5	2		90	86	81	76	71	65.5	60	55	50	40	30	20	10				
-	PQ 300	2.2	3		100	95	90	85	80	75	70	65	60	50	40	30	20	10			

MODEL		POWER		Q	Flow rate										
Single-phase	Three-phase	kW	HP		m³/h	0	0.12	0.24	0.36	0.48	0.60	0.72	0.84	0.96	1.08
				l/min	0	2	4	6	8	10	12	14	16	18	
PQm 81	PQ 81	0.50	0.70	H metres	90	80	71	63	54	45	37	28	19	10	
PQm 81-Bs	PQ 81-Bs	0.50	0.70		90	80	71	63	54	45	37	28	19	10	

⇒ PQ 81 Bs= version with brass pump body

Q = Flow rate H = Total manometric head HS = Suction height

Tolerance of characteristic curves in compliance with EN ISO 9906 App. A.

POS.	COMPONENT	CONSTRUCTION CHARACTERISTICS					
1	PUMP BODY	Cast iron (brass for PQ 81-Bs), complete with threaded ports in compliance with ISO 228/1					
2	MOTOR BRACKET	Aluminium with brass insert (patented), reduces the risk of impeller seizure					
3	IMPELLER	Brass, with peripheral radial vanes					
4	MOTOR SHAFT	Stainless steel EN 10088-3 - 1.4104					
5	MECHANICAL SEAL	Pump	Seal	Shaft	Materials		
		<i>Model</i>	<i>Model</i>	<i>Diameter</i>	<i>Stationary ring</i>	<i>Rotational ring</i>	<i>Elastomer</i>
		PQ 60-65	AR-12	Ø 12 mm	Ceramic	Graphite	NBR
		PQ 70-80-81-81Bs-90	FN-12	Ø 12 mm	Ceramic	Graphite	NBR
		PQ 100-200-300	FN-14	Ø 14 mm	Graphite	Ceramic	NBR
6	BEARINGS	Pump	Model				
		PQ 60-65-81-81Bs	6201 ZZ / 6201 ZZ				
		PQ 70-80-90	6203 ZZ / 6203 ZZ				
		PQ 100-200-300	6204 ZZ / 6204 ZZ				
7	CAPACITOR	Pump	Capacitance				
		<i>Single-phase</i>	<i>(230 V or 240 V)</i>	<i>(110 V)</i>			
		PQm 60	10 µF 450 VL	25 µF 250 VL			
		PQm 65	14 µF 450 VL	30 µF 250 VL			
		PQm 70	16 µF 450 VL	60 µF 300 VL			
		PQm 80	20 µF 450 VL	60 µF 300 VL			
		PQm 81 - 81Bs	14 µF 450 VL	30 µF 250 VL			
		PQm 90	20 µF 450 VL	60 µF 300 VL			
		PQm 100	31.5 µF 450 VL	60 µF 250 VL			
		PQm 200	45 µF 450 VL	80 µF 250 VL			
8	ELECTRIC MOTOR	PQm: single-phase 230 V - 50 Hz with thermal overload protector built-in to the winding.					
		PQ: three-phase 230/400 V - 50 Hz.					
		<p>➔ Pumps fitted with the three-phase motor option offer IE2 (IEC 60034-30) class high performance</p> <ul style="list-style-type: none"> - Insulation: F class. - Protection: IP 44. 					

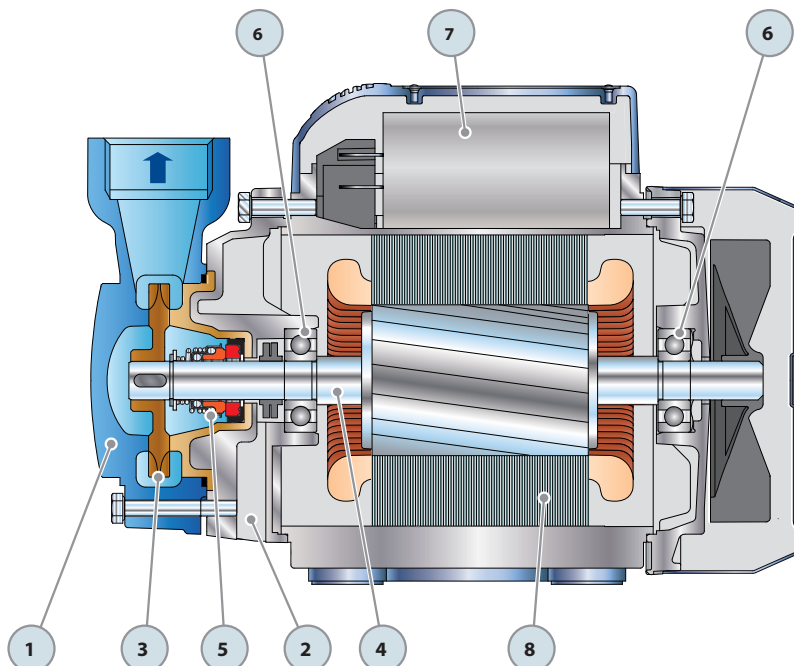

DIMENSIONS AND WEIGHT

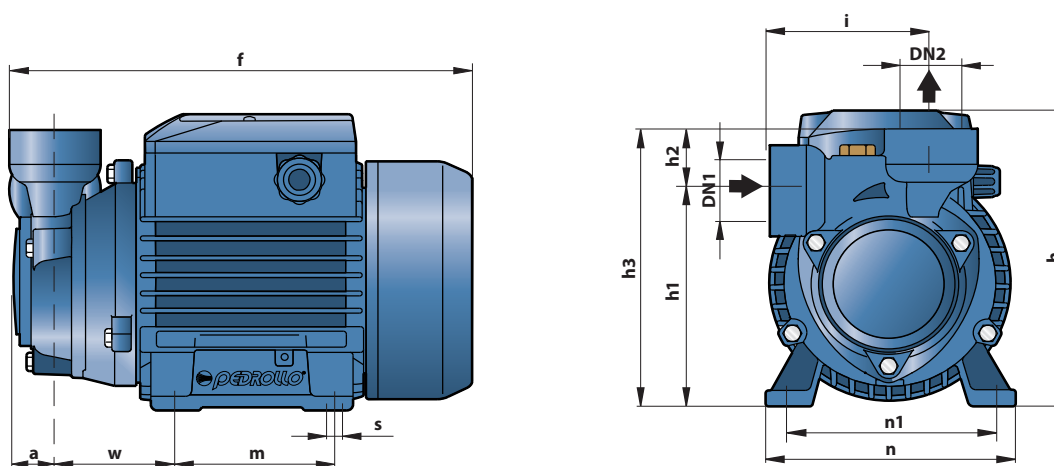

MODEL		PORTS		DIMENSIONS mm											kg		
Single-phase	Three-phase	DN1	DN2	a	f	h	h1	h2	h3	i	m	n	n1	w	s	1~	3~
PQm 60	PQ 60	1"	1"	22	225	152	108	30	138	78	80	120	100	55	7	5.1	5.1
PQm 65	PQ 65						113		143					57		6.6	6.1
PQm 70	PQ 70						121		151					62		9.7	9.0
PQm 80	PQ 80						126		153					62		9.7	9.0
PQm 81	PQ 81	1/2"	1/2"	18	220	152	119	23	141	71	80	120	100	58		6.6	6.2
PQm 81-Bs	PQ 81-Bs	1/2"	1/2"	18	220	152	119	23	141	71	80	120	100	58		6.5	6.1
PQm 90	PQ 90	3/4"	3/4"	22	255	180	126	27	153	84	90	138	112	62		9.9	8.8
PQm 100	PQ 100	1"	1"	25	318	212	140	30	170	89	100	164	125	85	9	14.1	12.2
PQm 200	PQ 200															15.2	14.1
-	PQ 300															-	15.2

ABSORPTION

MODEL	VOLTAGE (single-phase)		
	230 V	240 V	110 V
Single-phase	230 V	240 V	110 V
PQm 60	2.6 A	2.4 A	5.2 A
PQm 65	3.7 A	3.4 A	7.4 A
PQm 70	5.2 A	4.8 A	10.8 A
PQm 80	5.2 A	4.8 A	10.8 A
PQm 81	3.4 A	2.7 A	5.8 A
PQm 81-Bs	3.4 A	2.7 A	5.8 A
PQm 90	5.6 A	5.1 A	11.5 A
PQm 100	9.0 A	8.2 A	18.0 A
PQm 200	12.0 A	11.0 A	24.0 A

MODEL	VOLTAGE (three-phase)				
	230 V	400 V	690 V	240 V	415 V
Three-phase	230 V	400 V	690 V	240 V	415 V
PQ 60	2.0 A	1.15 A	-	1.9 A	1.1 A
PQ 65	3.0 A	1.7 A	-	2.8 A	1.6 A
PQ 70	3.8 A	2.2 A	-	3.3 A	1.9 A
PQ 80	3.8 A	2.2 A	-	3.3 A	1.9 A
PQm 81	2.2 A	1.3 A	-	2.0 A	1.15 A
PQm 81-Bs	2.2 A	1.3 A	-	2.0 A	1.15 A
PQ 90	4.2 A	2.4 A	-	3.8 A	2.2 A
PQ 100	6.3 A	3.6 A	2.05 A	5.7 A	3.3 A
PQ 200	7.6 A	4.4 A	2.5 A	7.0 A	4.0 A
PQ 300	9.3 A	5.4 A	3.15 A	8.7 A	5.0 A

PALLETIZATION

MODEL		GROUPAGE				CONTAINER			
Single-phase	Three-phase	n° pumps	H (mm)	kg		n° pumps	H (mm)	kg	
				1~	3~			1~	3~
PQm 60	PQ 60	240	1440	1250	1250	270	1600	1400	1400
PQm 65	PQ 65	240	1440	1600	1490	270	1600	1800	1670
PQm 70	PQ 70	120	1270	1190	1100	180	1850	1770	1640
PQm 80	PQ 80	120	1280	1190	1100	180	1850	1770	1640
PQm 81	PQ 81	192	1460	1290	1210	264	1960	1760	1660
PQm 81-Bs	PQ 81-Bs	192	1460	1270	1190	264	1960	1740	1630
PQm 90	PQ 90	120	1280	1210	1080	180	1850	1800	1610
PQm 100	PQ 100	72	1510	1040	900	96	1970	1380	1190
PQm 200	PQ 200	72	1510	1120	1040	96	1970	1480	1380
-	PQ 300	72	1510	-	1120	96	1970	-	1480

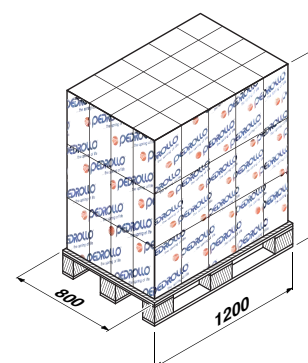

PQ 3000

Pump with peripheral impeller



PERFORMANCE RANGE

- Flow rate up to **50 l/min** (3 m³/h)
- Head up to **180 m**

APPLICATION LIMITS

- Manometric suction lift up to **8 m**
- Liquid temperature between **-10 °C** and **+90 °C**
- Ambient temperature between **-10 °C** and **+40 °C**
- Max. working pressure **18 bar**
- Continuous service **S1**

CONSTRUCTION AND SAFETY STANDARDS

EN 60034-1
IEC 60034-1
CEI 2-3



CERTIFICATIONS



INSTALLATION AND USE

Suitable for use with clean water and liquids that are not chemically aggressive towards the materials from which the pump is made. The hydraulic characteristics of this pump, coupled with its compactness, make it suitable for use in the industrial applications. The pump should be installed in an enclosed environment, or at least sheltered from inclement weather.

PATENTS - TRADE MARKS - MODELS

- Motor bracket: patent n° IT1243605

OPTIONALS AVAILABLE ON REQUEST

- Special mechanical seal
- EN 10088-3 - 1.4401 (AISI 316) stainless steel motor shaft
- Other voltages or 60 Hz frequency

GUARANTEE

1 year subject to terms and conditions

CHARACTERISTIC CURVES AND PERFORMANCE DATA

50 Hz n= 2900 1/min HS= 0 m

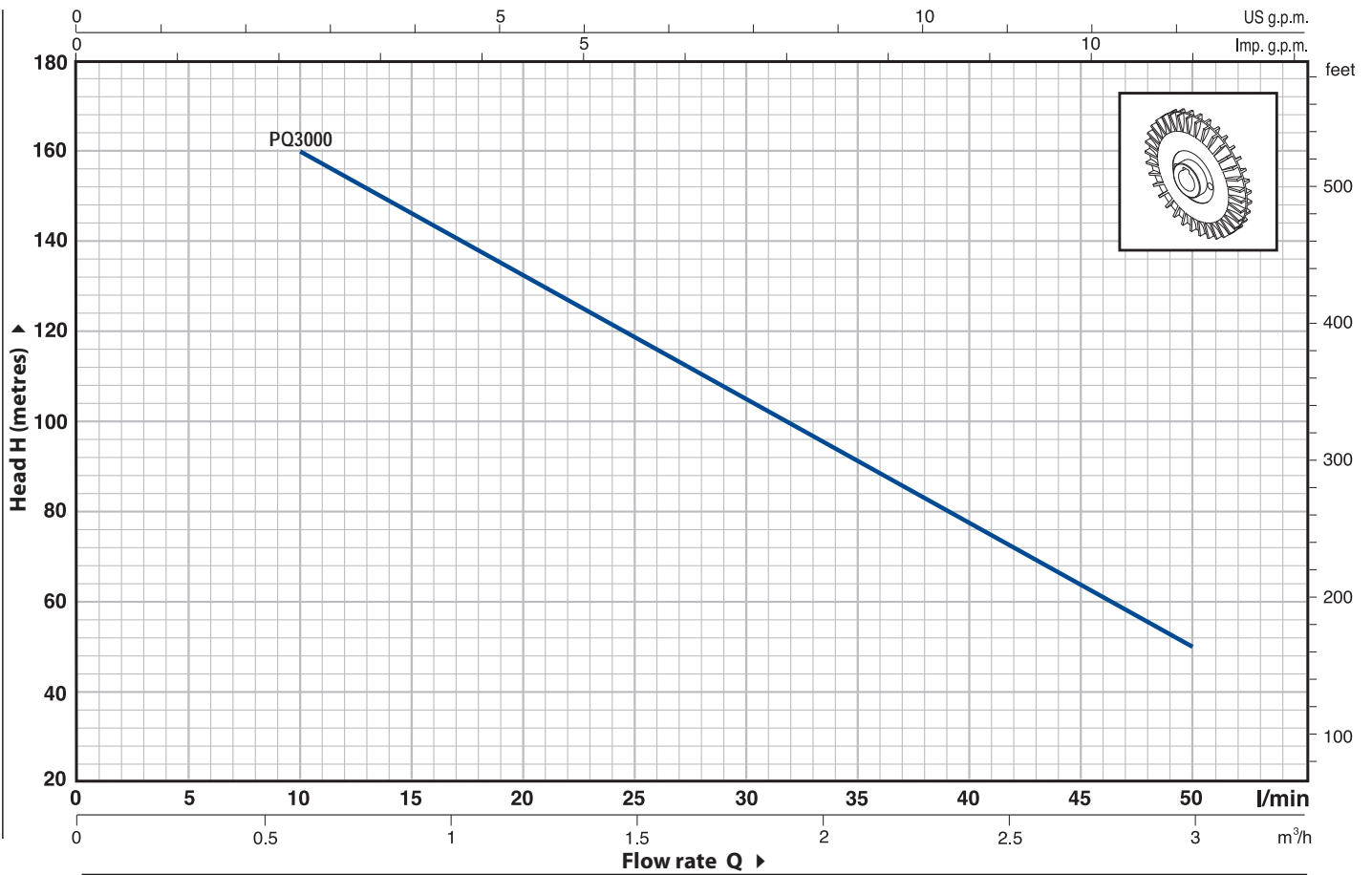

MODEL	POWER		Q	Flow rate									
	kW	HP		0	0.6	0.9	1.2	1.5	1.8	2.1	2.4	2.7	3.0
Three-phase				0	10	15	20	25	30	35	40	45	50
PQ 3000	2.2	3	H metres	180	160	145	132	118	105	92	78	63.5	50

Q = Flow rate H = Total manometric head HS = Suction height

Tolerance of characteristic curves in compliance with EN ISO 9906 App. A.

PQ 3000

POS.	COMPONENT	CONSTRUCTION CHARACTERISTICS				
1	PUMP BODY	Cast iron, complete with threaded ports in compliance with ISO 228/1				
2	BODY PLATE	Brass, with stainless steel shim disc				
3	MOTOR BRACKET	Aluminium, with brass insert and stainless steel shim disc that reduces the risk of impeller seizure				
4	IMPELLER	Bronze, with peripheral radial vanes				
5	MOTOR SHAFT	Stainless steel EN 10088-3 - 1.4104				
6	MECHANICAL SEAL	<i>Seal</i>	<i>Shaft</i>	<i>Materials</i>		
		<i>Model</i>	<i>Diameter</i>	<i>Stationary ring</i>	<i>Rotational ring</i>	<i>Elastomer</i>
		FN-18 NU	Ø 18 mm	Graphite	Ceramic	NBR
7	BEARINGS	6204 ZZ - C3 / 6204 ZZ - C3				
8	ELECTRIC MOTOR	PQ 3000: three-phase 230/400 V - 50 Hz. ⇒ Pump fitted with the three-phase motor option offers IE2 (IEC 60034-30) class high performance – Insulation: H class. – Protection: IP 55.				

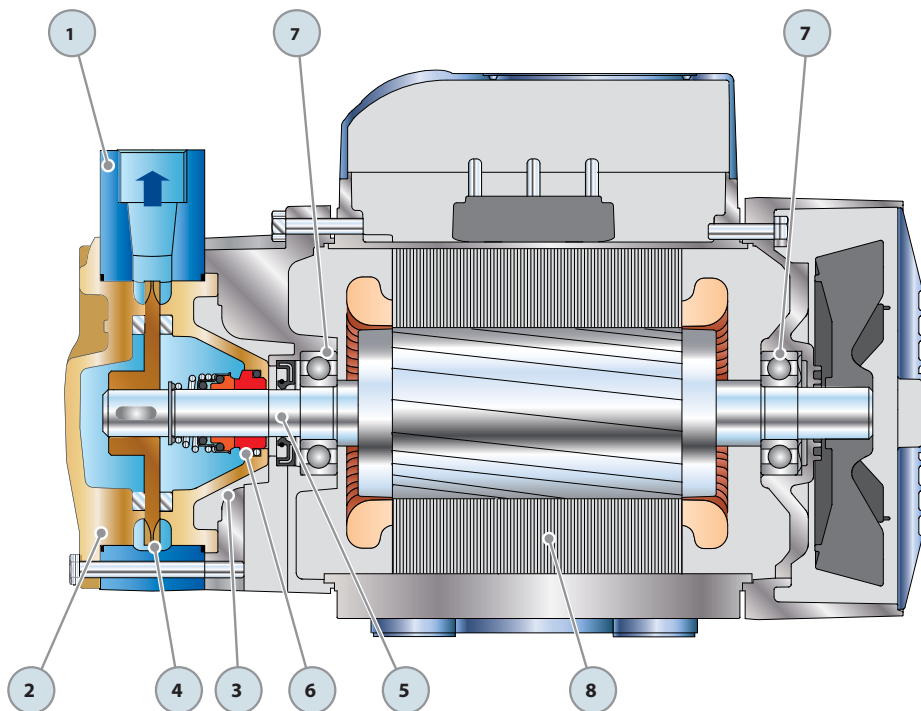

DIMENSIONS AND WEIGHT

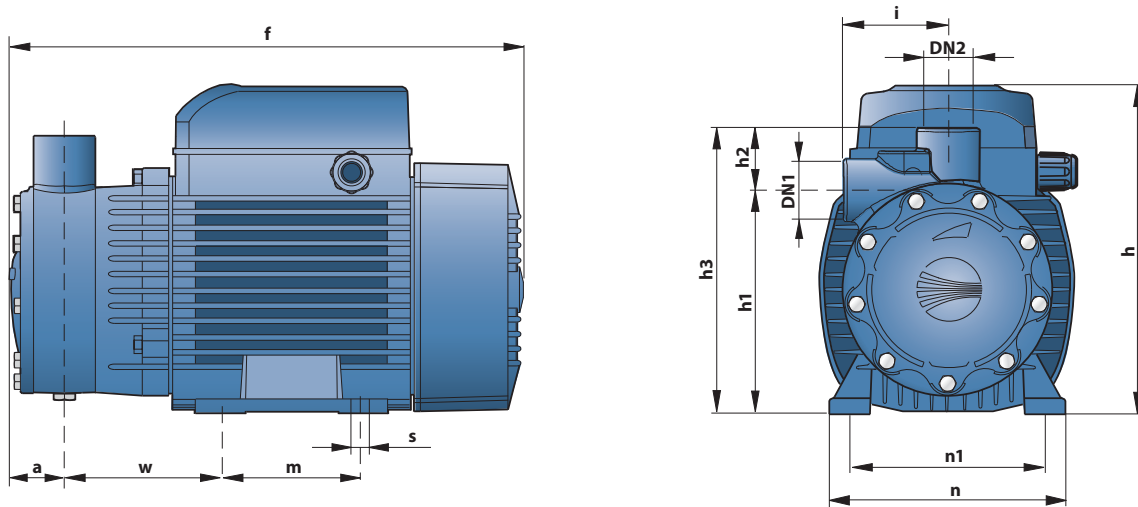

MODEL	PORTS		DIMENSIONS mm											kg		
	DN1	DN2	a	f	h	h1	h2	h3	i	m	n	n1	w		s	
Three-phase																3~
PQ 3000	¾"	¾"	34	329	212	142	38	180	65	100	164	125	97	9	18.8	

ABSORPTION

MODEL	VOLTAGE (three-phase)			
	Three-phase	230 V	400 V	240 V
PQ 3000	11.5 A	6.6 A	10.8 A	6.2 A

PALLETIZATION

MODEL	GROUPAGE			CONTAINER		
	n° pumps	H (mm)	kg	n° pumps	H (mm)	kg
PQ 3000	72	1840	1380	84	2114	1600

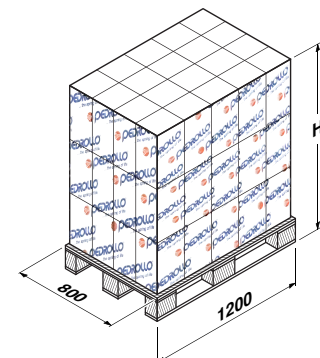



PERFORMANCE RANGE

- Flow rate up to **10 l/min** (0.6 m³/h)
- **50 Hz**: head up to **42 m**
- **60 Hz**: head up to **55 m**

APPLICATION LIMITS

- Manometric suction lift up to **8 m**
- Liquid temperature between **-10 °C** and **+90 °C**
- Ambient temperature between **-10 °C** and **+40 °C**
- Max. working pressure **10 bar**
- Continuous service **S1**

CONSTRUCTION AND SAFETY STANDARDS

EN 60034-1
IEC 60034-1
CEI 2-3



CERTIFICATIONS



AN30



VspTECT-003

INSTALLATION AND USE

Suitable for use with clean water and liquids that are not chemically aggressive towards the materials from which the pump is made. The design of this particularly compact brass pump offers an effective guarantee against the formation of rust and oxidation; as a result they are recommended for use in industrial applications such as cooling and conditioning. The pump should be installed in an enclosed environment, or at least sheltered from inclement weather.

PATENTS - TRADE MARKS - MODELS

- Motor bracket: patented n° IT1243605
- Registered Community Design n° 342159-0002

OPTIONALS AVAILABLE ON REQUEST

- Special mechanical seal
- EN 10088-3 - 1.4401 (AISI 316) stainless steel motor shaft
- Other voltages
- IP55 class protection

GUARANTEE

1 year subject to terms and conditions

CHARACTERISTIC CURVES AND PERFORMANCE DATA

50/60 Hz n= 2900/3450 1/min HS= 0 m

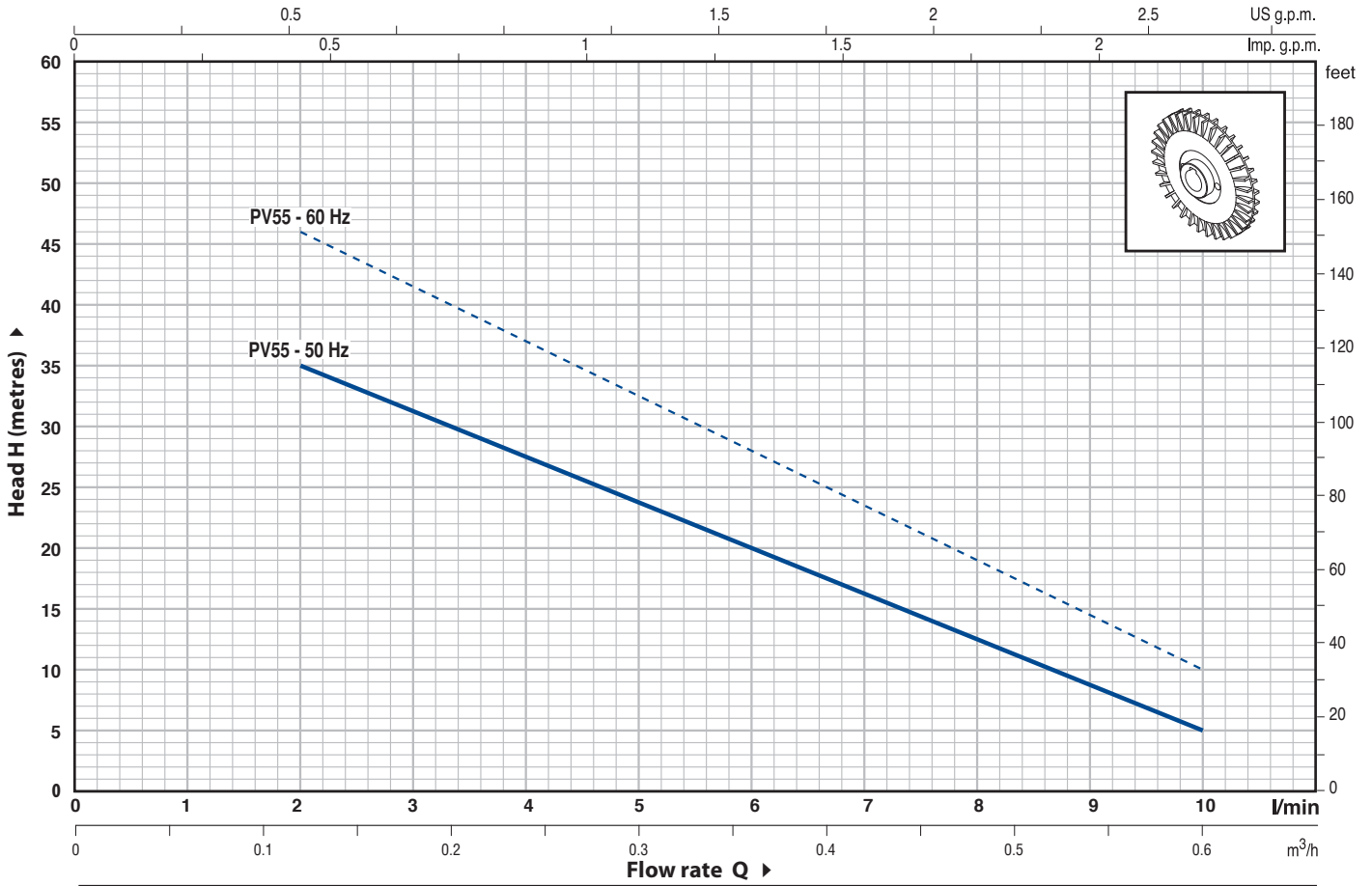

MODEL		POWER		Q	Flow rate										
Single-phase	Three-phase	kW	HP		m³/h	0	0.12	0.18	0.24	0.30	0.36	0.42	0.48	0.54	0.60
PVm 55	PV 55	0.18	0.25	H metres	50 Hz	42	35	31	27.5	24	20.5	16	12.5	9	5
					60 Hz	55	46	41.5	37	32.5	28	23.5	19	14.5	10

Q = Flow rate H = Total manometric head HS = Suction height

Tolerance of characteristic curves in compliance with EN ISO 9906 App. A.

➡ The PV 55 pump is designed to work at 50 Hz and 60 Hz (see the characteristic curves)

POS.	COMPONENT	CONSTRUCTION CHARACTERISTICS				
1	PUMP BODY	Brass, with threaded ports in compliance with ISO 228/1				
2	PUMP BODY BACK-PLATE	Brass				
3	MOTOR BRACKET	Aluminium				
4	IMPELLER	Brass, with peripheral radial vanes				
5	MOTOR SHAFT	Stainless steel EN 10088-3 - 1.4104				
6	MECHANICAL SEAL	Seal	Shaft	Materials		
		<i>Model</i>	<i>Diameter</i>	<i>Stationary ring</i>	<i>Rotational ring</i>	<i>Elastomer</i>
		PNL-12E	Ø 12 mm	Ceramic	Graphite	EPDM
7	BEARINGS	6201 ZZ / 6201 ZZ				
8	CAPACITOR	Capacitance				
		230÷240 V (50÷60 Hz)	110 V (50÷60 Hz)			
		10 µF 450 VL	25 µF 250 VL			
9	ELECTRIC MOTOR	<p>PV_m: single-phase 230 V - 50÷60 Hz with thermal overload protector built-in to the winding. PV: three-phase 230/400 V - 50÷60 Hz.</p> <p>➔ Pump fitted with the three-phase motor option offers IE2 (IEC 60034-30) class high performance</p> <ul style="list-style-type: none"> - Insulation: F class. - Protection: IP 44. 				

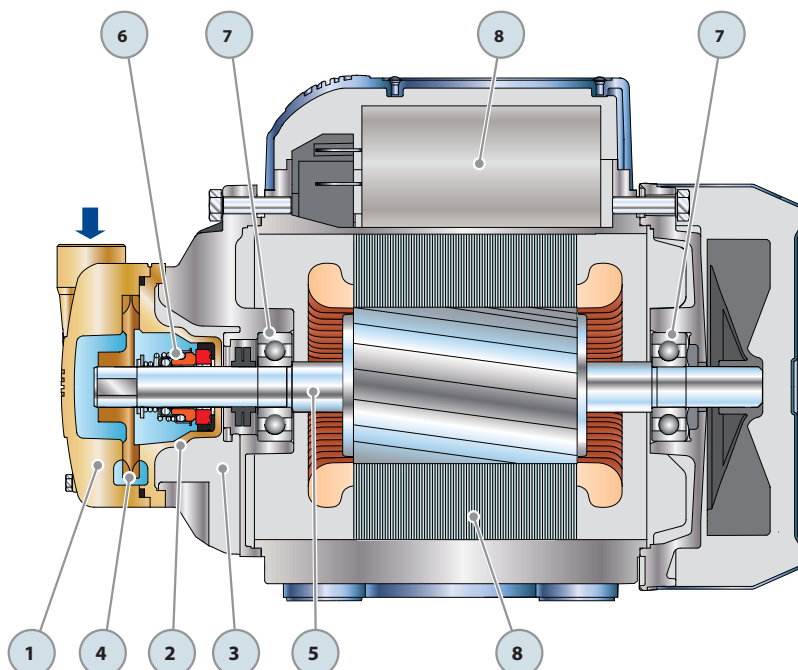

DIMENSIONS AND WEIGHT

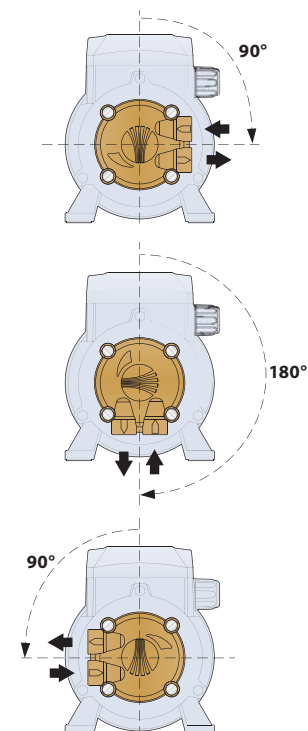
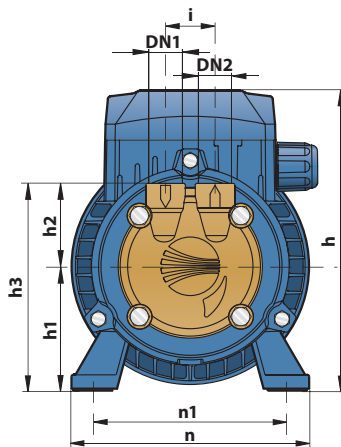
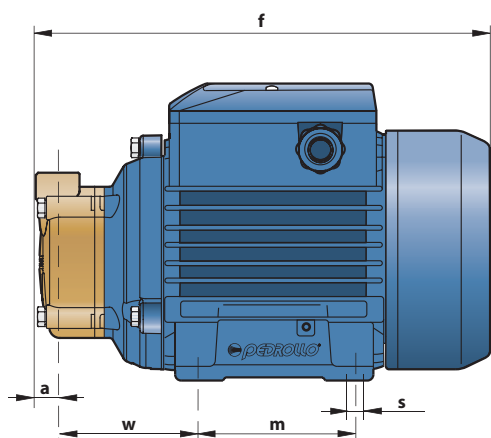

When rotating the pump body it is also necessary to rotate the pump body back-plate

MODEL		PORTS		DIMENSIONS mm												kg	
Single-phase	Three-phase	DN1	DN2	a	f	h	h1	h2	h3	i	m	n	n1	w	s	1~	3~
PVm 55	PV 55	1/4"	1/4"	11	223	152	63	42	105	25	80	120	100	65	7	4.6	4.6

ABSORPTION

MODEL	VOLTAGE (single-phase)		
Single-phase	230 V	240 V	110 V
PVm 55 (50Hz)	1.6 A	1.5 A	3.2 A
PVm 55 (60Hz)	2.0 A	1.9 A	4.0 A

MODEL	VOLTAGE (three-phase)	
Three-phase	230 V	400 V
PV 55 (50Hz)	1.7 A	1.0 A
PV 55 (60Hz)	1.7 A	1.0 A

PALLETIZATION

MODEL		GROUPAGE				CONTAINER			
Single-phase	Three-phase	n° pumps	H (mm)	kg		n° pumps	H (mm)	kg	
				1~	3~			1~	3~
PVm 55	PV 55	192	1460	910	910	264	1960	1240	1240

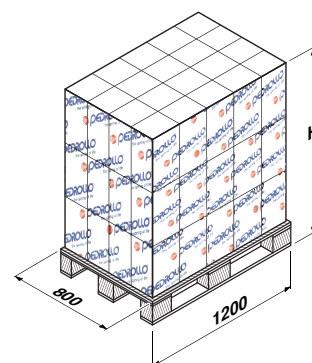

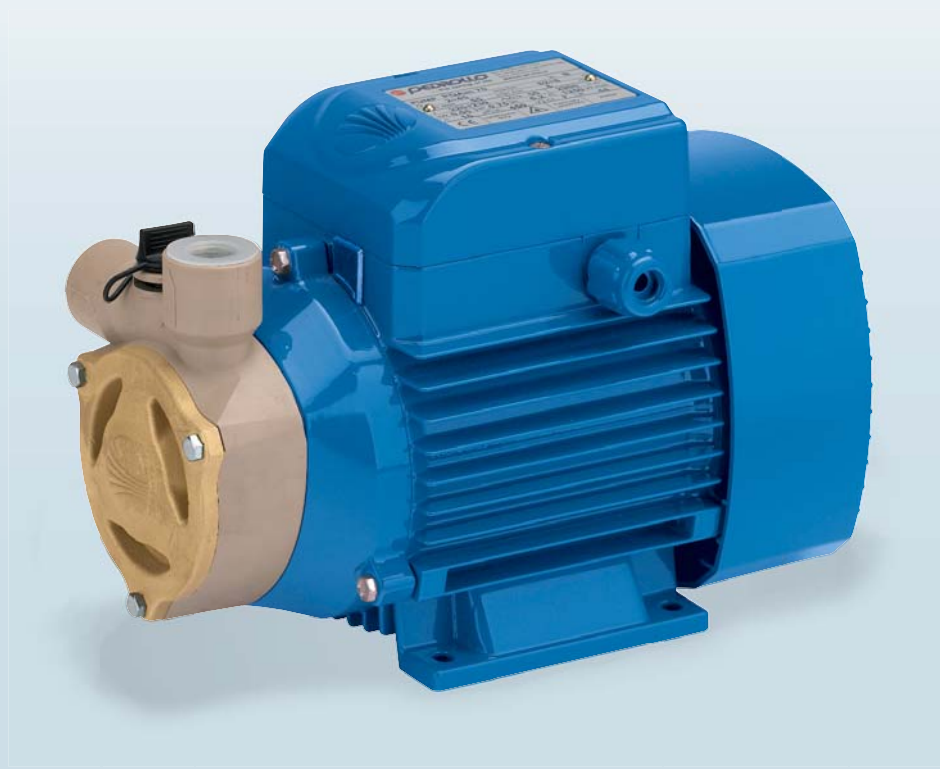

PERFORMANCE RANGE

- Flow rate up to **50 l/min** (3 m³/h)
- Head up to **90 m**

APPLICATION LIMITS

- Manometric suction lift up to **8 m**
- Liquid temperature between **-10 °C** and **+90 °C**
- Ambient temperature between **-10 °C** and **+40 °C**
- Max. working pressure **10 bar**
- Continuous service **S1**

CONSTRUCTION AND SAFETY STANDARDS

EN 60034-1
IEC 60034-1
CEI 2-3



CERTIFICATIONS



INSTALLATION AND USE

Suitable for use with clean water that does not contain abrasive particles and liquids that are not chemically aggressive towards the materials from which the pump is made.

The RYTON and brass pump body construction guarantees against the formation of rust and oxidation. As a result of these characteristics these pumps are suitable for use in industrial applications such as cooling, conditioning and boiler feed.

The pump should be installed in an enclosed environment, or at least sheltered from inclement weather.

PATENTS - TRADE MARKS - MODELS

- Motor bracket: patented n° IT1243605
- Registered Community Design n° 342159-001

OPTIONALS AVAILABLE ON REQUEST

- Special mechanical seal
- EN 10088-3 - 1.4401 (AISI 316) stainless steel motor shaft
- Other voltages or 60 Hz frequency
- IP55 class protection

GUARANTEE

1 year subject to terms and conditions

CHARACTERISTIC CURVES AND PERFORMANCE DATA

50 Hz n= 2900 1/min HS= 0 m

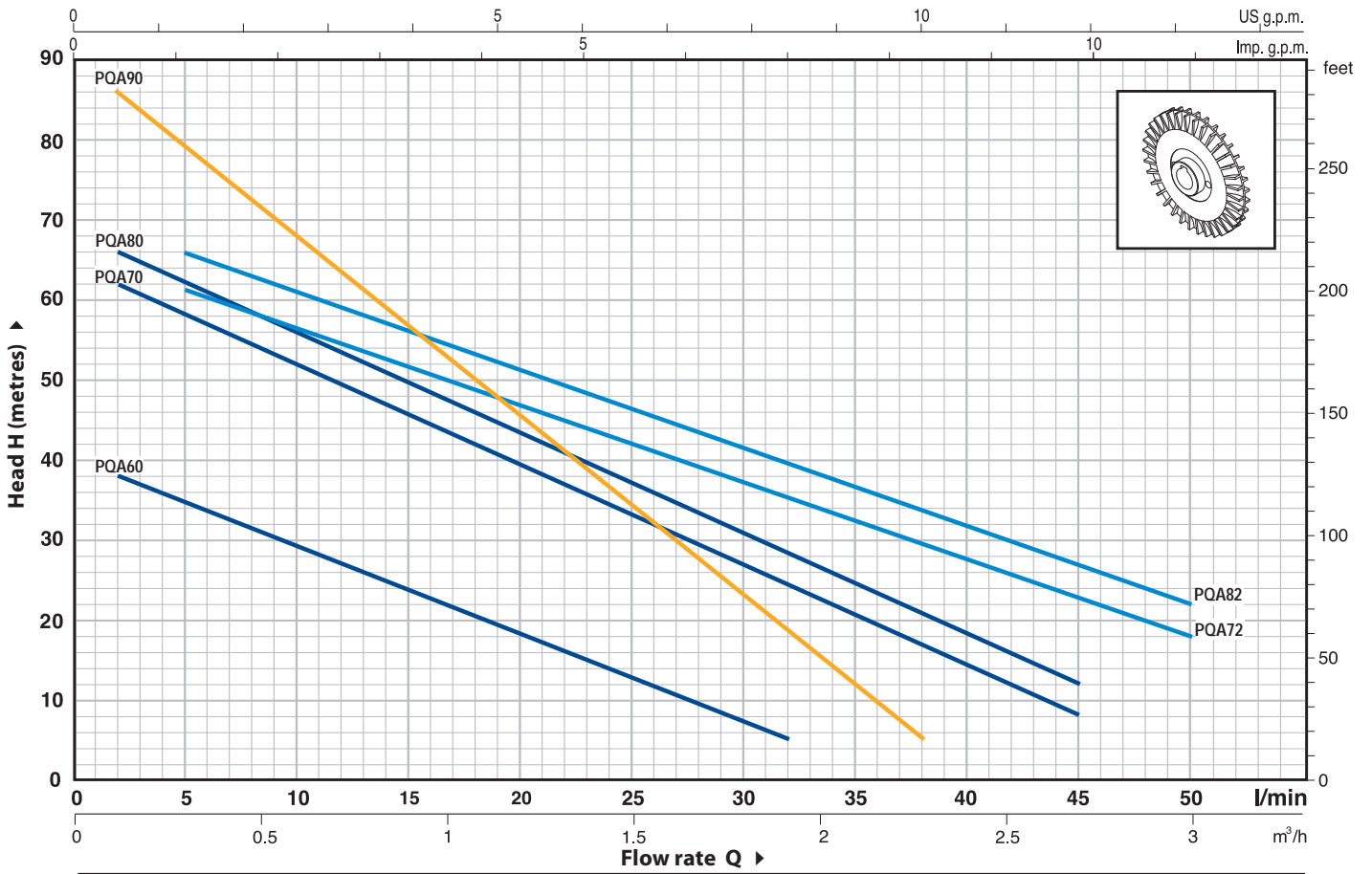

MODEL		POWER		Q	H metres														
Single-phase	Three-phase	kW	HP		m³/h	0	0.1	0.3	0.6	0.9	1.2	1.5	1.8	1.9	2.3	2.7	3.0		
				l/min	0	2	5	10	15	20	25	30	32	38	45	50			
PQAm 60	PQA 60	0.37	0.50	H metres	40	38	35	29	23.5	18	12.5	7	5						
PQAm 70	PQA 70	0.55	0.75		65	62	58	52	45.5	39.5	33	27	24	16.5	8				
PQAm 72	PQA 72	0.55	0.75		65	-	62	57	52	47	42	37.5	35.5	29.5	22.5	18			
PQAm 80	PQA 80	0.75	1		70	66	62	56	49.5	43	37	31	28	20.5	12				
PQAm 82	PQA 82	0.75	1		70	-	66	61	56	51	46	41.5	39.5	37.5	26.5	22			
PQAm 90	PQA 90	0.75	1		90	86	79	68	56.5	45.5	34	23	18.5	5					

Q = Flow rate H = Total manometric head HS = Suction height

Tolerance of characteristic curves in compliance with EN ISO 9906 App. A.

POS.	COMPONENT	CONSTRUCTION CHARACTERISTICS				
1	PUMP BODY	RYTON, complete with threaded metallic port inserts in compliance with ISO 228/1				
2	BODY PLATE	Brass				
3	MOTOR BRACKET	Aluminium with brass insert (patented), reduces the risk of impeller seizure				
4	IMPELLER	Brass, with peripheral radial vanes				
5	MOTOR SHAFT	Stainless steel EN 10088-3 - 1.4104				
6	MECHANICAL SEAL	<i>Seal</i>	<i>Shaft</i>	<i>Materials</i>		
		<i>Model</i>	<i>Diameter</i>	<i>Stationary ring</i>	<i>Rotational ring</i>	<i>Elastomer</i>
		FN-12	Ø 12 mm	Ceramic	Graphite	NBR
7	BEARINGS	<i>Pump</i>	<i>Model</i>			
		PQA 60	6201 ZZ / 6201 ZZ			
		PQA 70-72-80-82-90	6203 ZZ / 6203 ZZ			
8	CAPACITOR	<i>Pump</i>	<i>Capacitance</i>			
		<i>Single-phase</i>	<i>(230 V or 240 V)</i>	<i>(110 V)</i>		
		PQAm 60	10 µF 450 VL	25 µF 250 VL		
		PQAm 70-72	16 µF 450 VL	60 µF 250 VL		
		PQAm 80-82	20 µF 450 VL	60 µF 250 VL		
		PQAm 90	20 µF 450 VL	60 µF 250 VL		
9	ELECTRIC MOTOR	<p>PQAm: single-phase 230 V - 50 Hz with thermal overload protector built-in to the winding.</p> <p>PQA: three-phase 230/400 V - 50 Hz.</p> <p>⇒ Pumps fitted with the three-phase motor option offer IE2 (IEC 60034-30) class high performance</p> <ul style="list-style-type: none"> - Insulation: F class. - Protection: IP 44. 				

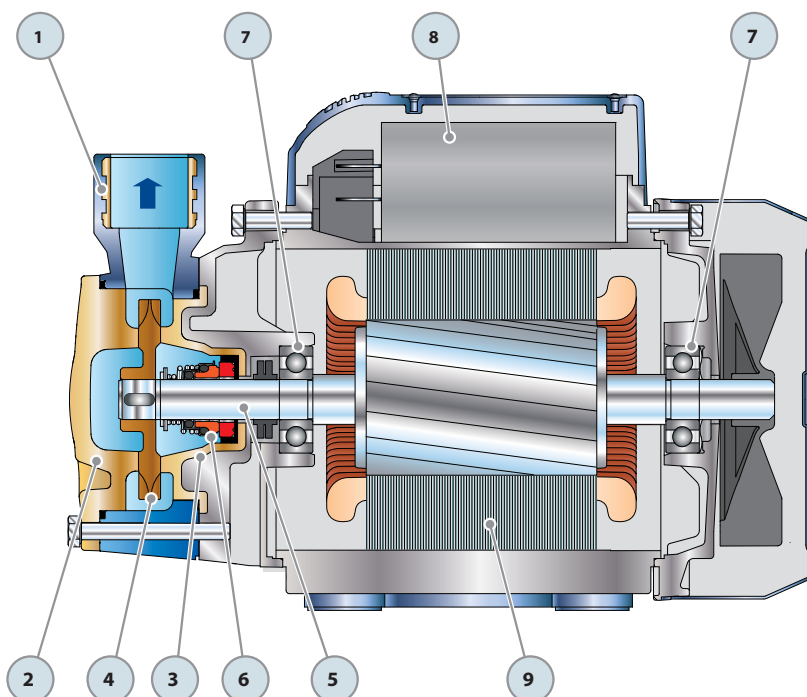

DIMENSIONS AND WEIGHT

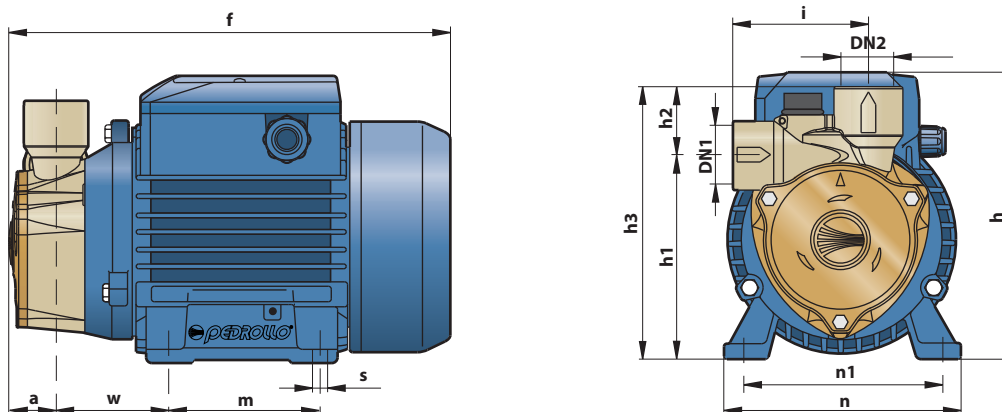

MODEL		PORTS		DIMENSIONS mm												kg	
Single-phase	Three-phase	DN1	DN2	a	f	h	h1	h2	h3	i	m	n	n1	w	s	1~	3~
PQAm 60	PQA 60	½"	½"	25	226	152	103	33	136	72.5	80	120	100	55	7	4.8	4.8
PQAm 70	PQA 70						116.5	32.5	149							9.4	8.4
PQAm 72	PQA 72	1"	1"	28	258	179	121	30	151	83	90	138	112	62	7	9.5	8.5
PQAm 80	PQA 80	½"	½"				116.5	32.5	149	72.5						9.4	8.4
PQAm 82	PQA 82	1"	1"	28	258	179	121	30	151	83	90	138	112	62	7	9.5	8.5
PQAm 90	PQA 90	½"	½"					35	156	76						72.5	9.5

ABSORPTION

MODEL	VOLTAGE (single-phase)		
	230 V	240 V	110 V
Single-phase	230 V	240 V	110 V
PQAm 60	2.5 A	2.4 A	5.2 A
PQAm 70	6.2 A	5.5 A	10.8 A
PQAm 72	6.2 A	5.5 A	10.8 A
PQAm 80	6.3 A	5.5 A	10.8 A
PQAm 82	6.3 A	5.5 A	10.8 A
PQAm 90	5.6 A	5.1 A	11.5 A

MODEL	VOLTAGE (three-phase)			
	230 V	400 V	240 V	415 V
Three-phase	230 V	400 V	240 V	415 V
PQA 60	2.0 A	1.15 A	1.9 A	1.1 A
PQA 70	4.2 A	2.4 A	3.7 A	2.2 A
PQA 72	4.2 A	2.4 A	3.7 A	2.2 A
PQA 80	4.2 A	2.4 A	3.7 A	2.2 A
PQA 82	4.2 A	2.4 A	3.7 A	2.2 A
PQA 90	4.2 A	2.4 A	3.8 A	2.2 A

PALLETIZATION

MODEL		GROUPAGE				CONTAINER			
Single-phase	Three-phase	n° pumps	H (mm)	kg		n° pumps	H (mm)	kg	
				1~	3~			1~	3~
PQAm 60	PQA 60	192	1490	940	940	264	1990	1290	1290
PQAm 70	PQA 70	120	1310	1150	1030	180	1900	1710	1530
PQAm 72	PQA 72	120	1310	1160	1040	180	1900	1730	1550
PQAm 80	PQA 80	120	1310	1150	1030	180	1900	1710	1530
PQAm 82	PQA 82	120	1310	1160	1040	180	1900	1730	1550
PQAm 90	PQA 90	120	1310	1160	1040	180	1900	1730	1550

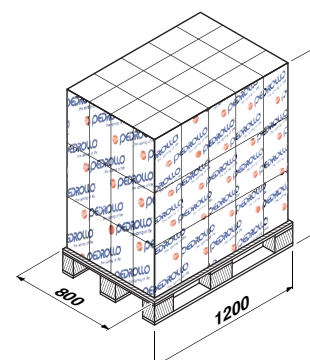



PERFORMANCE RANGE

- Flow rate up to **160 l/min** (9.6 m³/h)
- Head up to **58 m**

APPLICATION LIMITS

- Manometric suction lift up to **7 m**
- Liquid temperature between **-10 °C** and **+90 °C**
(up to +40 for the version with the technopolymer impeller)
- Ambient temperature up to **+40 °C**
- Max. working pressure:
 - **6 bar** for CP 100-130-132-150-158
 - **10 bar** for CP 170-190-200
- Continuous service **S1**

CONSTRUCTION AND SAFETY STANDARDS

EN 60034-1
IEC 60034-1
CEI 2-3



CERTIFICATIONS



AN30



UKPTECT-003

INSTALLATION AND USE

Suitable for use with clean water and liquids that are not chemically aggressive towards the materials from which the pump is made. As a result of their reliability and the fact that they are easy to use, these pumps are widely used in domestic and civil applications such as the distribution of water in combination with small and medium sized pressure sets, for transferring liquids and for the irrigation of gardens and allotments. The pump should be installed in an enclosed environment, or at least sheltered from inclement weather.

PATENTS - TRADE MARKS - MODELS

- Registered Community Design n° 406160-0001

OPTIONALS AVAILABLE ON REQUEST

- Pump with technopolymer impeller
- Special mechanical seal
- Other voltages or 60 Hz frequency
- IP55 class protection for CP 170, CP 170M

GUARANTEE

1 year subject to terms and conditions

CHARACTERISTIC CURVES AND PERFORMANCE DATA

50 Hz n= 2900 1/min HS= 0 m

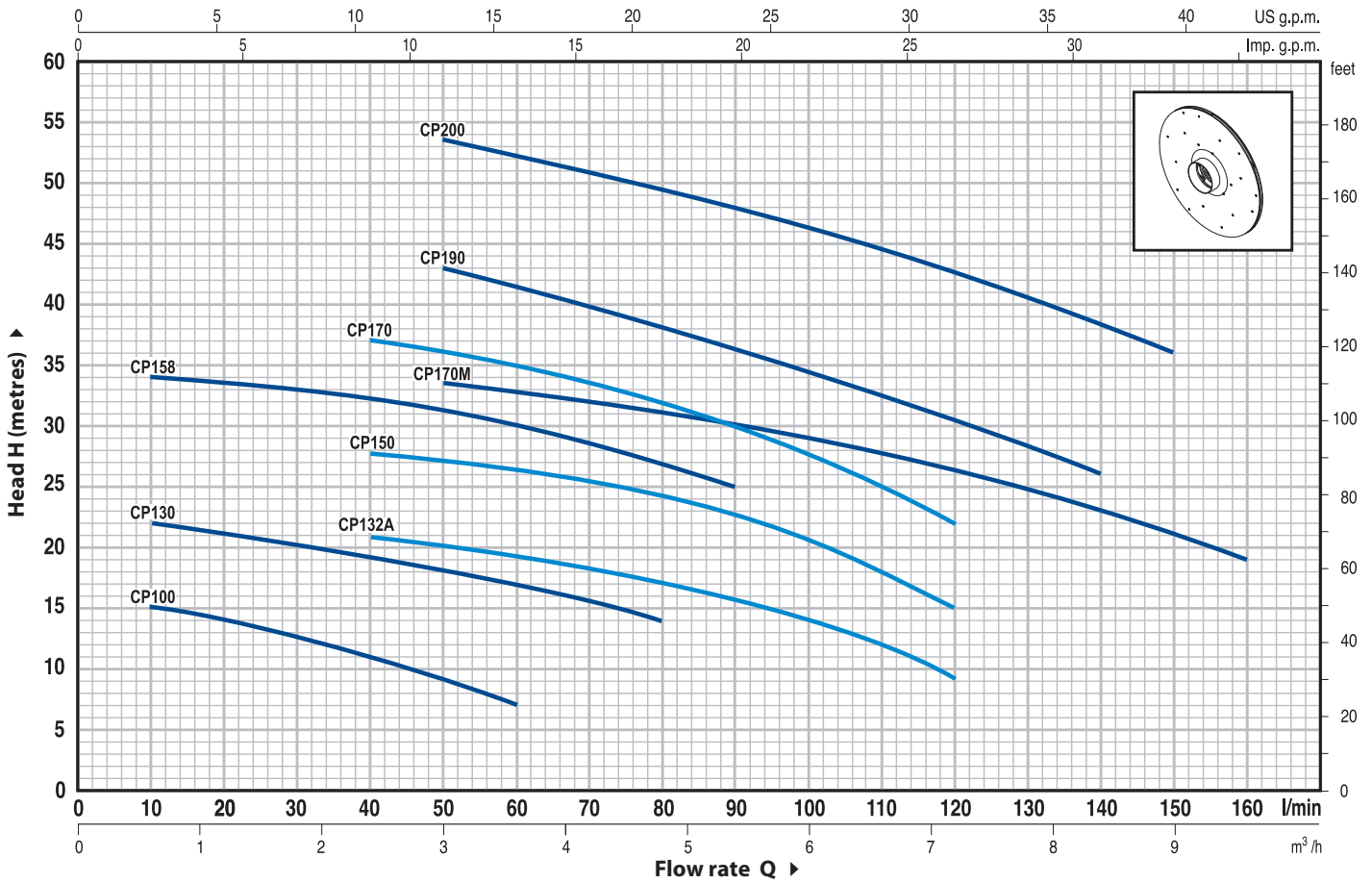

MODEL		POWER		Q	Flow rate																		
Single-phase	Three-phase	kW	HP		m³/h	0	0.6	1.2	1.8	2.4	3.0	3.6	4.2	4.8	5.4	6.0	6.6	7.2	7.8	8.4	9.0	9.6	
				l/min	0	10	20	30	40	50	60	70	80	90	100	110	120	130	140	150	160		
CPm 100	-	0.25	0.33	H metres	16	15	14	12.5	11	9	7												
CPm 130	CP 130	0.37	0.50		23	22	21	20	19	18	17	15.5	14										
CPm 132A	CP 132A	0.60	0.85		23	-	22	21.5	21	20	19	18	17	16	14	12	9						
CPm 150	CP 150	0.75	1		29.5	-	29	28.5	28	27.5	26.5	26	24.5	23	21	18	15						
CPm 158	CP 158	0.75	1		36	34	33.5	33	32.5	31.5	30	28.5	27	25									
CPm 170	CP 170	1.1	1.5		41	-	-	38	37	36	35	33.5	32	30	27.5	25	22						
CPm 170M	CP 170M	1.1	1.5		36	-	-	35	34.5	33.5	33	32	31	30	29	28	26.5	25	23	21	19		
CPm 190	CP 190	1.5	2		50	-	-	46	44.5	43	41.5	40	38	36	34.5	32.5	30.5	28	26				
-	CP 200	2.2	3		58	-	-	55	54.5	53.5	52	51	49.5	48	46	44.5	42.5	40.5	38.5	36			

Q = Flow rate H = Total manometric head HS = Suction height

Tolerance of characteristic curves in compliance with EN ISO 9906 App. A.

POS.	COMPONENT	CONSTRUCTION CHARACTERISTICS					
1	PUMP BODY	Cast iron, complete with threaded ports in compliance with ISO 228/1					
2	BODY BACKPLATE	Stainless steel AISI 304 (cast iron for CP 190-200)					
3	IMPELLER	Stainless steel AISI 304					
4	MOTOR SHAFT	Stainless steel EN 10088-3 - 1.4104					
5	MECHANICAL SEAL	<i>Pump</i>	<i>Seal</i>	<i>Shaft</i>	<i>Materials</i>		
		<i>Model</i>	<i>Model</i>	<i>Diameter</i>	<i>Stationary ring</i>	<i>Rotational ring</i>	<i>Elastomer</i>
		CP 100-130-132A	AR-12	Ø 12 mm	Ceramic	Graphite	NBR
		CP 150-158	AR-14	Ø 14 mm	Ceramic	Graphite	NBR
CP 170-170M-190-200	FN-18	Ø 18 mm	Graphite	Ceramic	NBR		
6	BEARINGS	<i>Pump</i>	<i>Model</i>				
		CP 100-130-132A	6201 ZZ / 6201 ZZ				
		CP 150-158	6203 ZZ / 6203 ZZ				
		CP 170-170M	6204 ZZ / 6204 ZZ				
		CP 190-200	6304 ZZ / 6204 ZZ				
7	CAPACITOR	<i>Pump</i>	<i>Capacitance</i>				
		<i>Single-phase</i>	<i>(230 V or 240 V)</i>	<i>(110 V)</i>			
		CPm 100	10 µF 450 VL	25 µF 250 VL			
		CPm 130	10 µF 450 VL	30 µF 250 VL			
		CPm 132A	14 µF 450 VL	30 µF 250 VL			
		CPm 150-158	20 µF 450 VL	60 µF 300 VL			
		CPm 170-170M	25 µF 450 VL	60 µF 250 VL			
		CPm 190	45 µF 450 VL	80 µF 250 VL			
8	ELECTRIC MOTOR	CPm: single-phase 230 V - 50 Hz with thermal overload protector built-in to the winding.					
		CP: three-phase 230/400 V - 50 Hz.					
		<p>➔ Pumps fitted with the three-phase motor option offer IE2 (IEC 60034-30) class high performance</p> <ul style="list-style-type: none"> - Insulation: F class. - Protection: IP 44. 					

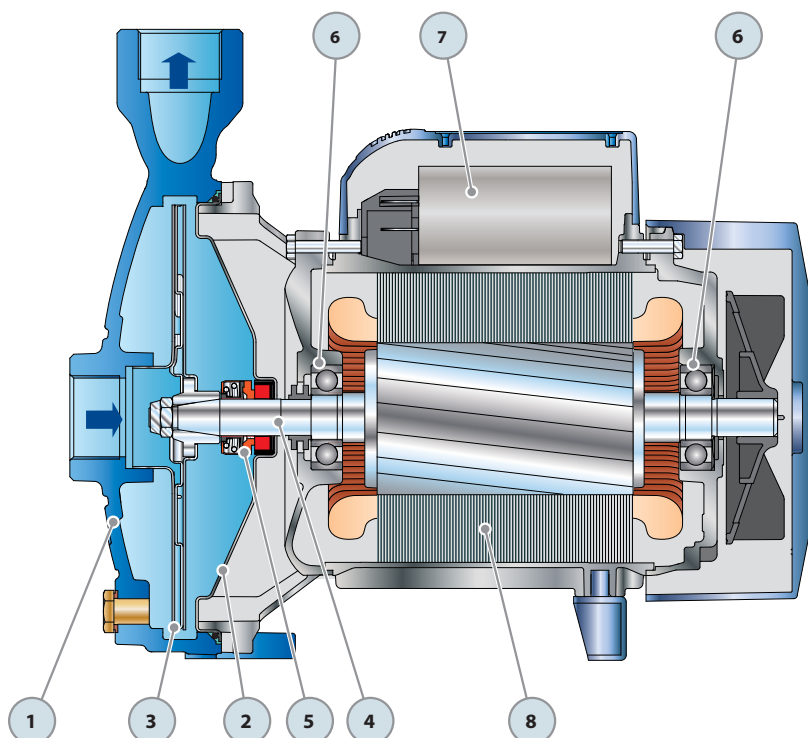

DIMENSIONS AND WEIGHT

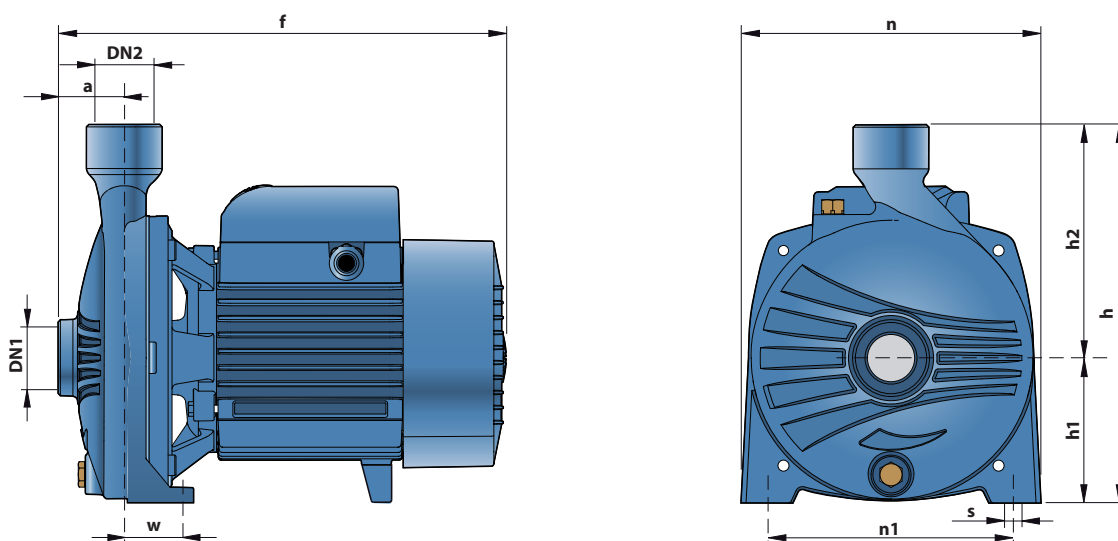

MODEL		PORTS		DIMENSIONS mm									kg	
Single-phase	Three-phase	DN1	DN2	a	f	h	h1	h2	n	n1	w	s	1~	3~
CPm 100	-	1"	1"	42	259	192	82	110	165	135	41	10	6.9	-
CPm 130	CP 130					205	82	123					7.6	7.1
CPm 132A	CP 132A					205	82	123					8.3	8.0
CPm 150	CP 150				285	92	148	12.4	11.4					
CPm 158	CP 158	1 1/4"	1"	51	367	240	110	150	206	165	44.5	11	12.0	11.0
CPm 170 - 170M	CP 170 - 170M					260	175	175					17.8	17.2
CPm 190	CP 190				364	115	175	242	206	32.5	22.3		21.3	
-	CP 200	-	-	-	-	-	-	-	-	-	-	-	-	22.5

ABSORPTION

MODEL	VOLTAGE (single-phase)		
	230 V	240 V	110 V
Single-phase	230 V	240 V	110 V
CPm 100	1.9 A	1.55 A	3.3 A
CPm 130	3.2 A	2.9 A	6.4 A
CPm 132A	3.5 A	3.2 A	7.0 A
CPm 150	5.7 A	5.4 A	11.4 A
CPm 158	6.0 A	5.8 A	12.0 A
CPm 170 - 170M	7.8 A	7.2 A	16.0 A
CPm 190	11.0 A	10.0 A	22.0 A

MODEL	VOLTAGE (three-phase)			
	230 V	400 V	240 V	415 V
Three-phase	230 V	400 V	240 V	415 V
CP 130	2.0 A	1.2 A	1.8 A	1.1 A
CP 132A	2.9 A	1.7 A	2.4 A	1.4 A
CP 150	4.2 A	2.4 A	4.1 A	2.4 A
CP 158	4.4 A	2.5 A	4.3 A	2.5 A
CP 170 - 170M	5.2 A	3.0 A	5.1 A	2.9 A
CP 190	7.5 A	4.3 A	7.3 A	4.2 A
CP 200	9.0 A	5.2 A	8.3 A	4.8 A

PALLETIZATION

MODEL		GROUPAGE				CONTAINER			
		n° pumps	H (mm)	kg		n° pumps	H (mm)	kg	
Single-phase	Three-phase			1~	3~			1~	3~
CPm 100	-	105	1280	741	-	189	2190	1321	-
CPm 130	CP 130	105	1280	820	770	189	2190	1460	1360
CPm 132A	CP 132A	105	1280	890	860	189	2190	1590	1530
CPm 150	CP 150	70	1450	890	820	112	2240	1410	1300
CPm 158	CP 158	70	1450	860	790	112	2240	1360	1250
CPm 170	CP 170	50	1560	900	870	70	2120	1250	1200
CPm 170M	CP 170M	50	1560	940	910	70	2120	1310	1260
CPm 190	CP 190	36	1410	820	790	54	2040	1220	1170
-	CP 200	36	1410	-	830	54	2040	-	1240

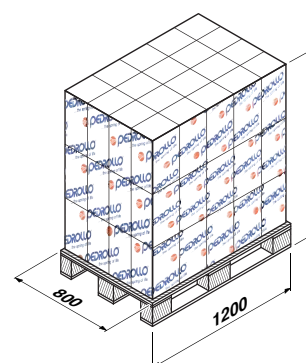



PERFORMANCE RANGE

- Flow rate up to **900 l/min** (54 m³/h)
- Head up to **74 m**

APPLICATION LIMITS

- Manometric suction lift up to **7 m**
- Liquid temperature between **-10 °C** and **+90 °C**
- Ambient temperature between **-10 °C** and **+40 °C**
- Max. working pressure **10 bar**
- Continuous service **S1**

CONSTRUCTION AND SAFETY STANDARDS

EN 60034-1
IEC 60034-1
CEI 2-3



CERTIFICATIONS



INSTALLATION AND USE

Suitable for use with clean water and liquids that are not chemically aggressive towards the materials from which the pump is made. As a result of their reliability and the fact that they are easy to use, these pumps are widely used in civil, agricultural and industrial applications such as for supplying water, in conditioning and cooling systems, for irrigation, etc. The pump should be installed in an enclosed environment, or at least sheltered from inclement weather.

PATENTS - TRADE MARKS - MODELS

- Registered Italian model n° 72753

OPTIONALS AVAILABLE ON REQUEST

- Special mechanical seal
- EN 10088-3 - 1.4401 (AISI 316) stainless steel motor shaft
- Other voltages or 60 Hz frequency
- IP55 class protection

GUARANTEE

1 year subject to terms and conditions

PERFORMANCE RANGE

50 Hz n= 2900 1/min HS= 0 m

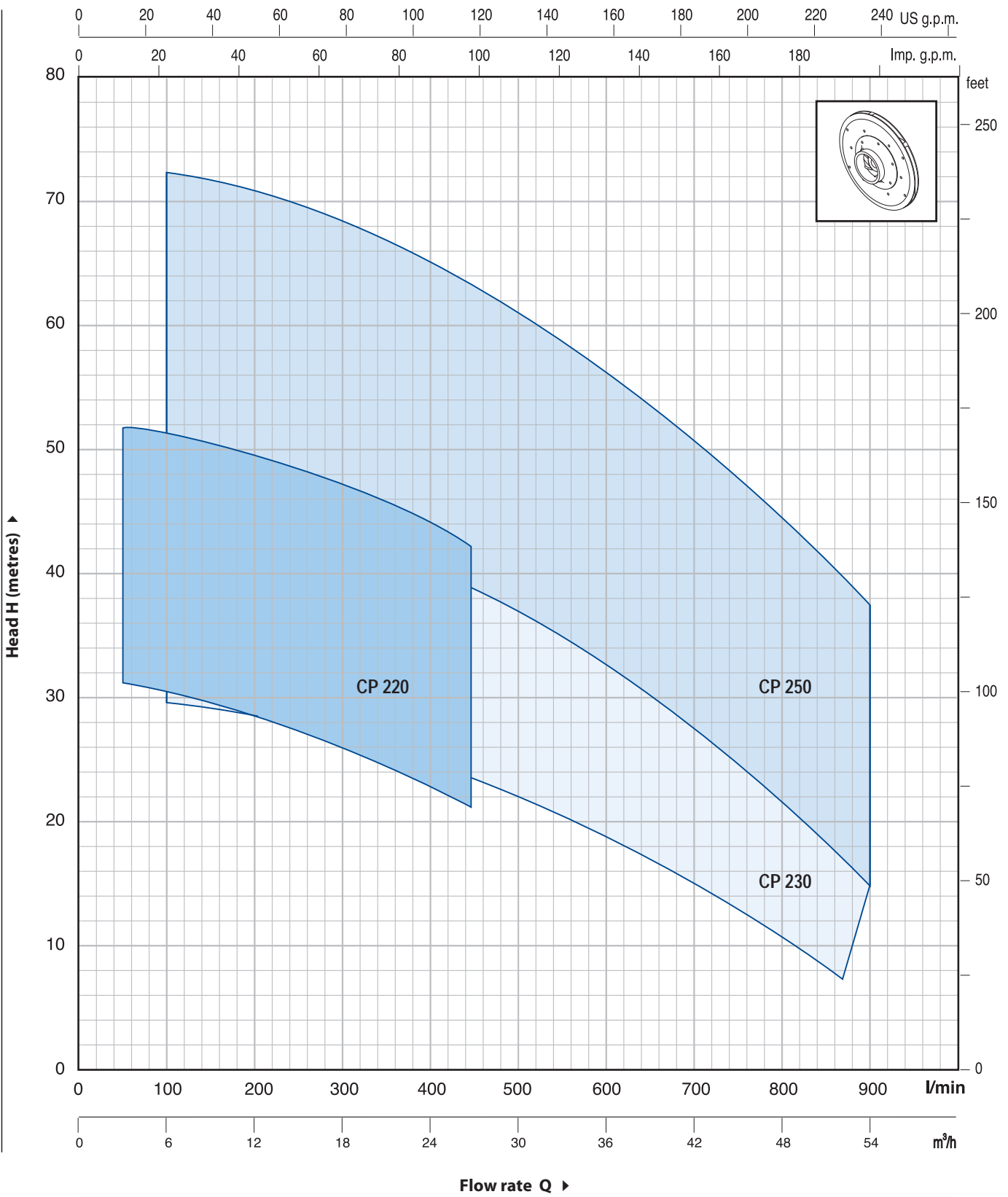

CHARACTERISTIC CURVES AND PERFORMANCE DATA

50 Hz n= 2900 1/min HS= 0 m

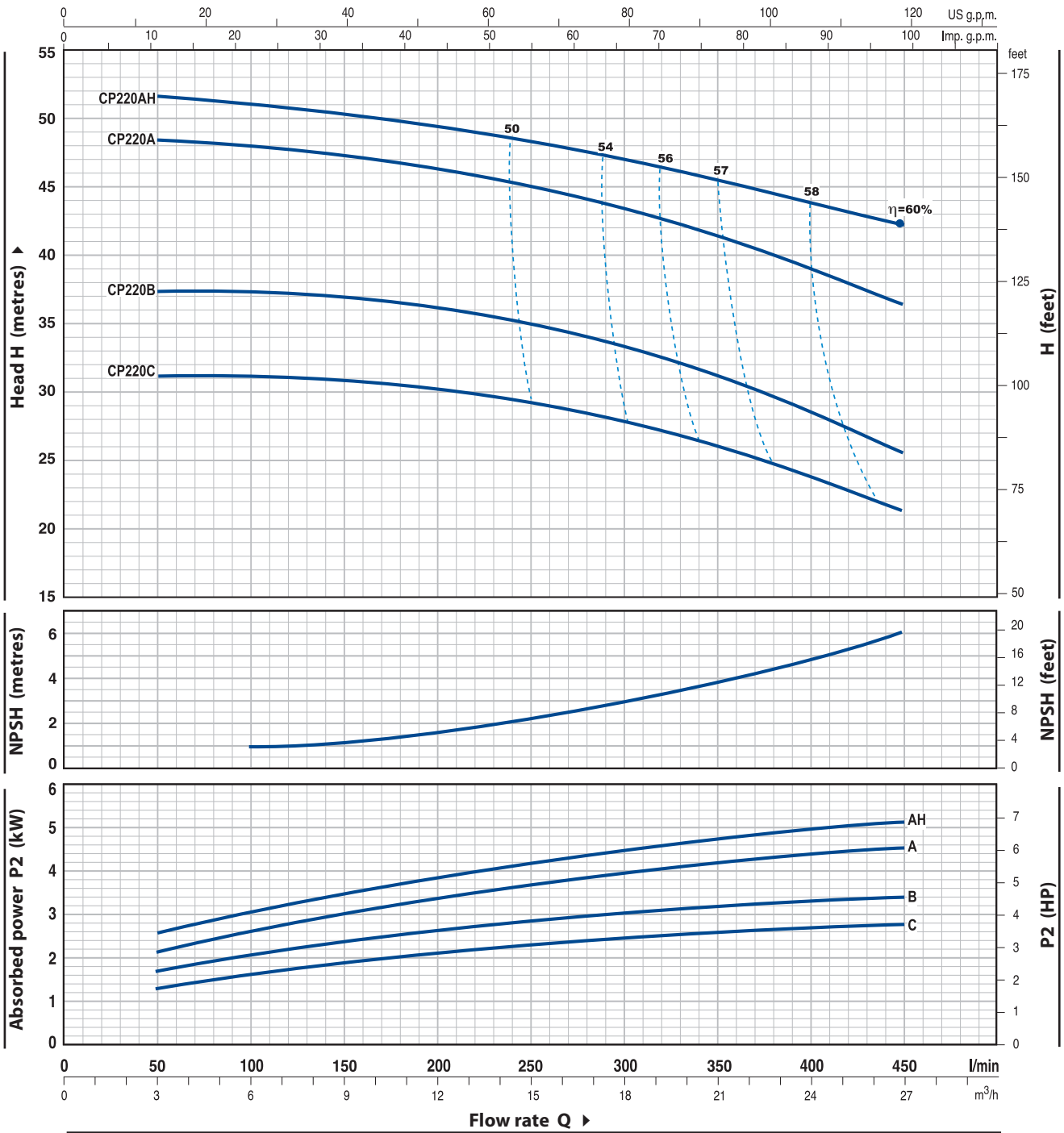

MODEL		POWER		Q	Flow rate Q						
Single-phase	Three-phase	kW	HP		m³/h	0	3	6	12	18	24
	CP 220C	2.2	3	H metres	0	50	100	200	300	400	450
-	CP 220B	3	4		32	31.5	31	30	28	24	21
-	CP 220A	4	5.5		38	37.5	37	36	33.5	29	25
-	CP 220AH	5.5	7.5		49	48.5	48	46	43.5	39.5	36
					52	51.5	51	49	47	44	42

Q = Flow rate H = Total manometric head HS = Suction height

Tolerance of characteristic curves in compliance with EN ISO 9906 App. A.

CHARACTERISTIC CURVES AND PERFORMANCE DATA

50 Hz n= 2900 1/min HS= 0 m

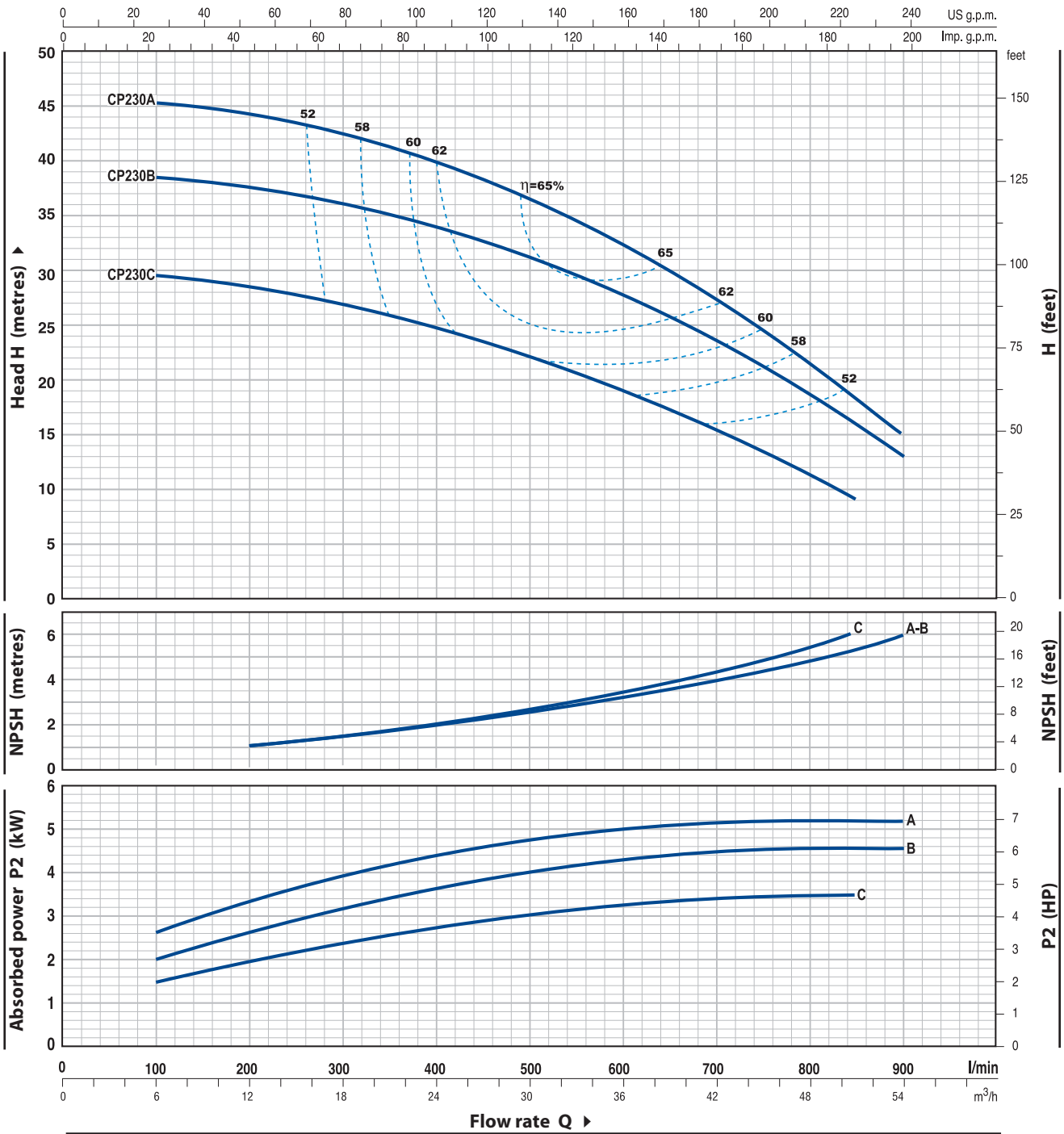

MODEL	POWER		Q	Flow rate												
	kW	HP		m ³ /h	0	6	12	18	24	30	36	42	48	51	54	
Three-phase			l/min	0	100	200	300	400	500	600	700	800	850	900		
CP 230C	3	4	H metres	30	29.5	28.5	27	25	22	19.5	15.5	11.5	9			
CP 230B	4	5.5		39	38.5	38	36	34	31	28	24	18.5	15	13		
CP 230A	5.5	7.5		46	45.5	44.5	42	40	37	32.5	27.5	21.5	18	15		

Q = Flow rate H = Total manometric head HS = Suction height

Tolerance of characteristic curves in compliance with EN ISO 9906 App. A.

CP 250

CHARACTERISTIC CURVES AND PERFORMANCE DATA

50 Hz n= 2900 1/min HS= 0 m

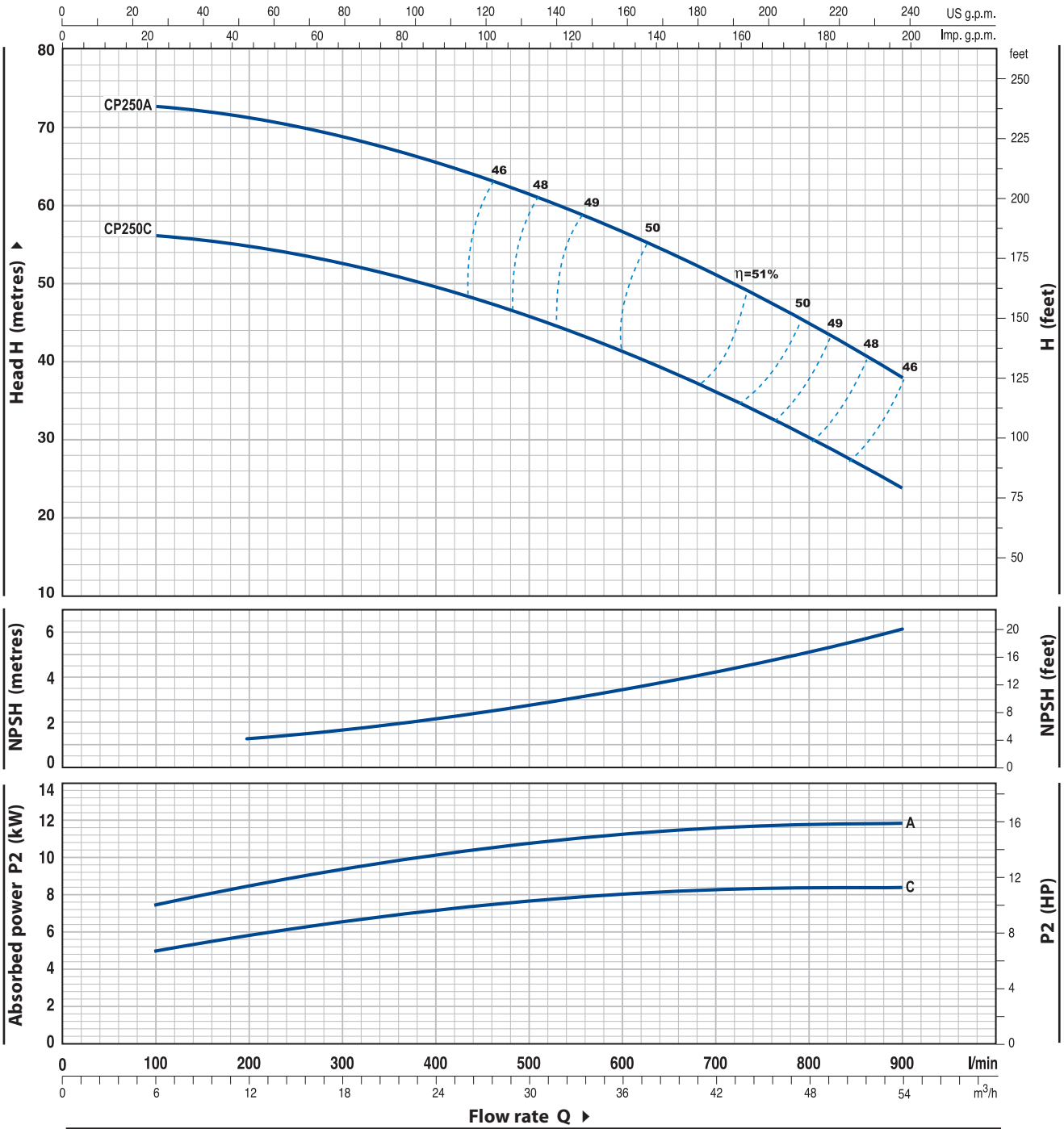

MODEL	POWER		Q	Flow rate												
	kW	HP		m ³ /h	0	6	12	18	24	30	36	42	48	54		
Three-phase			l/min	0	100	200	300	400	500	600	700	800	900			
CP 250C	7.5	10	H metres	57	56	54.5	52.5	49.5	46	41.5	35.5	30	24			
CP 250A	11	15		74	73	71	68	65	61	57	51	45	37			

Q = Flow rate H = Total manometric head HS = Suction height

Tolerance of characteristic curves in compliance with EN ISO 9906 App. A.

CHARACTERISTIC CURVES AND PERFORMANCE DATA

50 Hz n= 2900 1/min HS= 0 m

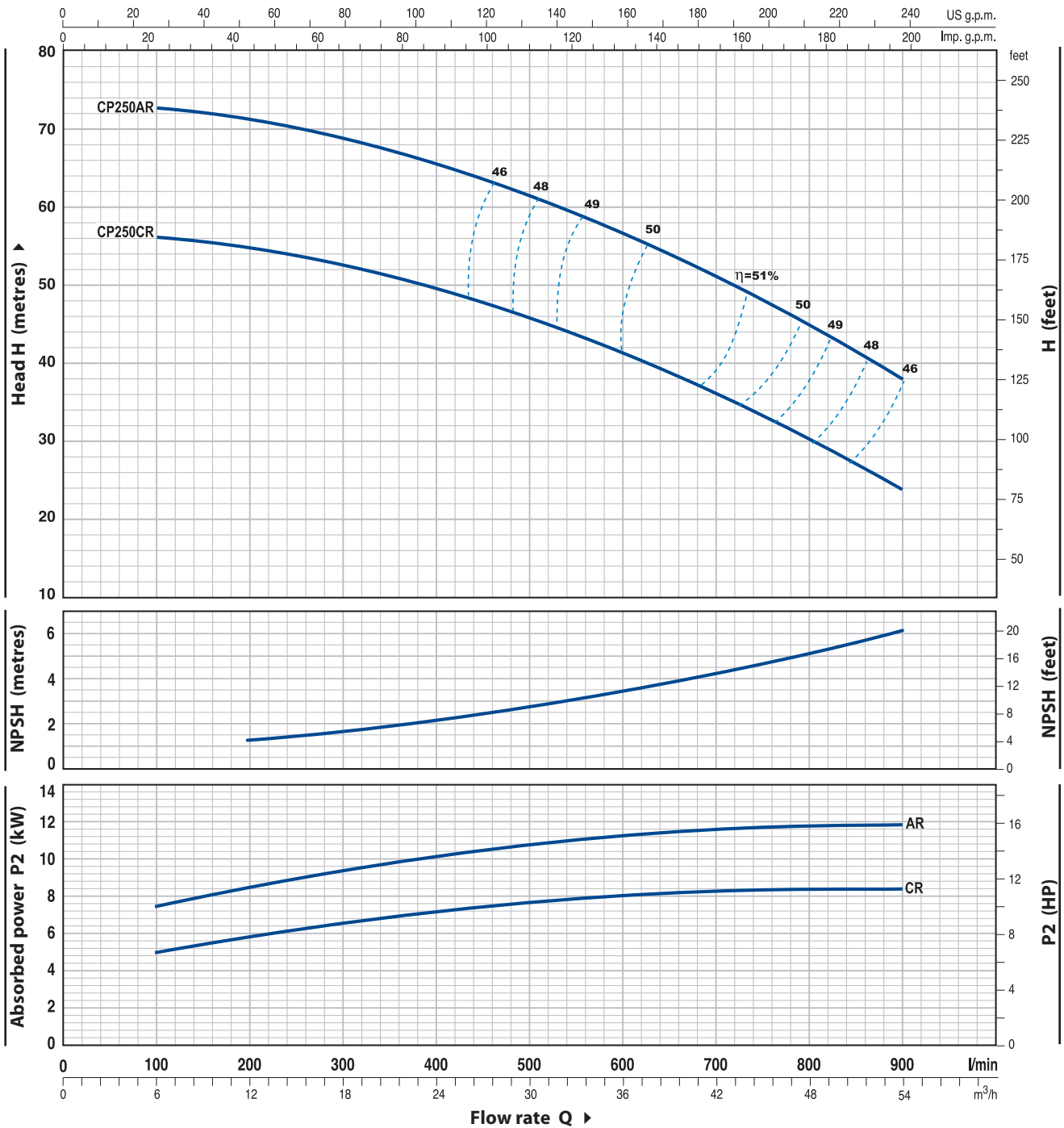

MODEL	POWER		Q	Flow rate												
	kW	HP		m ³ /h	0	6	12	18	24	30	36	42	48	54		
Three-phase			l/min	0	100	200	300	400	500	600	700	800	900			
CP 250CR	7.5	10	H metres	57	56	54.5	52.5	49.5	46	41.5	35.5	30	24			
CP 250AR	11	15		74	73	71	68	65	61	57	51	45	37			

Q = Flow rate H = Total manometric head HS = Suction height

Tolerance of characteristic curves in compliance with EN ISO 9906 App. A.

POS.	COMPONENT	CONSTRUCTION CHARACTERISTICS					
1	PUMP BODY	Cast iron, complete with threaded ports in compliance with ISO 228/1					
2	BODY BACKPLATE	Cast iron					
3	IMPELLER	Brass for CP 220, CP 230 Cast iron for CP 250					
4	MOTOR SHAFT	Stainless steel EN 10088-3 - 1.4104					
5	MECHANICAL SEAL	<i>Pump</i>	<i>Seal</i>	<i>Shaft</i>	<i>Materials</i>		
		<i>Model</i>	<i>Model</i>	<i>Diameter</i>	<i>Stationary ring</i>	<i>Rotational ring</i>	<i>Elastomer</i>
		CP 220C-B CP 230C	FN-20	Ø 20 mm	Graphite	Ceramic	NBR
		CP 220A-AH CP 230B-A CP 250C-CR	FN-24	Ø 24 mm	Graphite	Ceramic	NBR
		CP 250A-AR	FN-32 NU	Ø 32 mm	Graphite	Ceramic	NBR
6	BEARINGS	<i>Pump</i>	<i>Model</i>				
		CP 220C	6206 ZZ - C3 / 6204 ZZ				
		CPm 220C					
		CP 220B CP 230C	6206 ZZ - C3 / 6205 ZZ				
		CP 220A-AH CP 230B-A CP 250C-CR	6307 ZZ - C3 / 6206 ZZ - C3				
		CP 250A-AR	6310 ZZ - C3 / 6308 ZZ - C3				
7	CAPACITOR	<i>Pump</i>	<i>Capacitance</i>				
		<i>Single-phase</i>	(230 V or 240 V)				
		CPm 220C	70 µF 450 VL				
8	ELECTRIC MOTOR	CPm: single-phase 230 V - 50 Hz. CP: three-phase 230/400 V - 50 Hz up to 4 kW. 400/690 V - 50 Hz from 5.5 to 11 kW. ⇒ Pumps fitted with the three-phase motor option offer IE2 (IEC 60034-30) class high performance – Insulation: F class. – Protection: IP 44.					

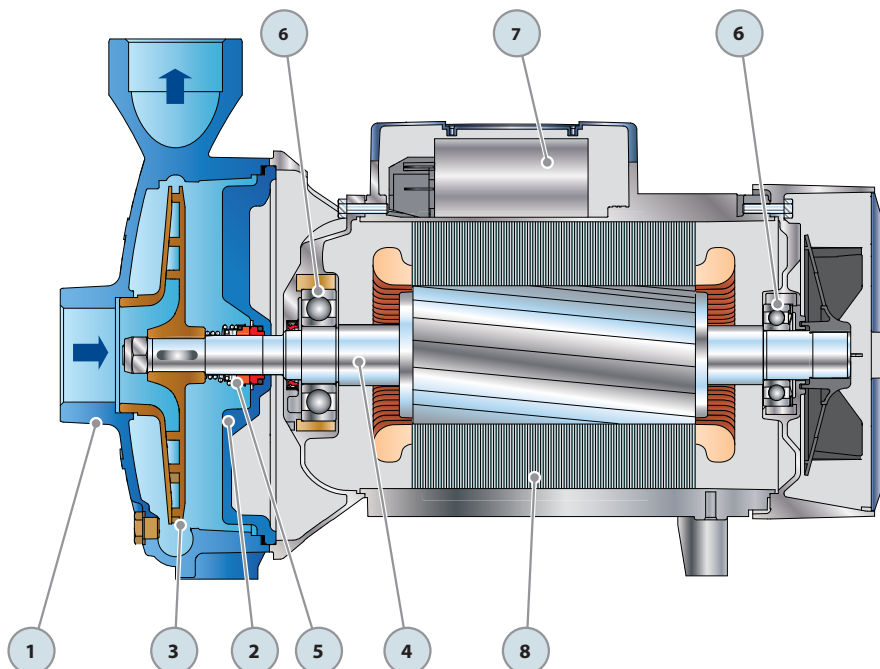

DIMENSIONS AND WEIGHT

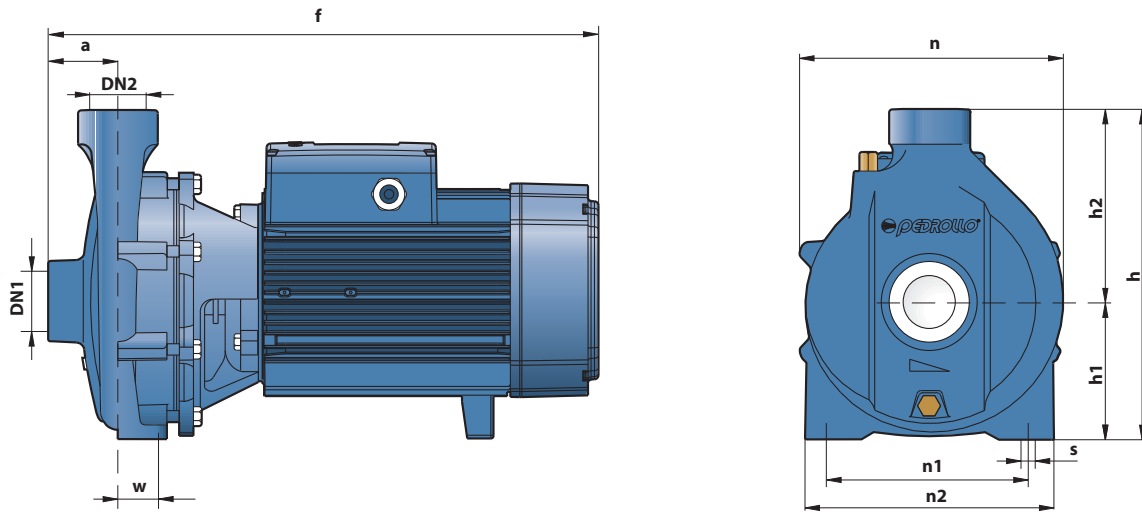

MODEL		PORTS		DIMENSIONS mm										kg			
Single-phase	Three-phase	DN1	DN2	a	f	h	h1	h2	n	n1	n2	w	s	1~	3~		
CPm 220C	CP 220C	2"	2"	70	426/409	315	132	183	255	170	230	40	14	-	-		
-	CP 220B				426											-	-
-	CP 220A				460												
-	CP 220AH				505												
-	CP 230C				426												
-	CP 230B				460												
-	CP 230A				505												
-	CP 250C				507												
-	CP 250A				571												
-	CP 250CR				534												
-	CP 250AR	598															
		4"	3"	92	534	392	160	232	322	230	294	45	-	-			

ABSORPTION

MODEL	VOLTAGE (single-phase)	
Single-phase	230 V	240 V
CPm 220C	15.8 A	15.0 A

MODEL	VOLTAGE (three-phase)					
Three-phase	230 V	400 V	690 V	240 V	415 V	720 V
CP 220C	11.4 A	6.6 A	3.8 A	10.7 A	6.2 A	3.6 A
CP 220B	12.6 A	7.3 A	4.2 A	12.0 A	7.0 A	4.0 A
CP 220A	17.0 A	9.8 A	5.7 A	16.5 A	9.5 A	5.5 A
CP 220AH	20.0 A	11.5 A	6.7 A	21.0 A	12.0 A	6.9 A
CP 230C	13.2 A	7.6 A	4.4 A	11.1 A	6.4 A	3.7 A
CP 230B	16.8 A	9.7 A	5.6 A	16.2 A	9.4 A	5.4 A
CP 230A	20.0 A	11.5 A	6.7 A	19.2 A	11.0 A	6.4 A
CP 250C-CR	28.6 A	16.5 A	9.5 A	27.5 A	16.0 A	9.3 A
CP 250A-AR	40.8 A	23.6 A	13.7 A	40.8 A	23.6 A	13.7 A

PALLETIZATION

MODEL		GROUPAGE			CONTAINER			
Single-phase	Three-phase	n° pumps	H (mm)	kg	n° pumps	H (mm)	1~	3~
CPm 220C	CP 220C	18	1220	590	24	1580	780	700
-	CP 220B	18	1180	-	24	1520	-	790
-	CP 220A	18	1430	-	24	1860	-	1000
-	CP 220AH	12	1430	-	16	1860	-	760
-	CP 230C	18	1200	-	24	1550	-	780
-	CP 230B	18	1430	-	24	1860	-	1000
-	CP 230A	12	1430	-	16	1860	-	760
-	CP 250C	6	1180	-	-	-	-	-
-	CP 250A	6	1180	-	-	-	-	-
-	CP 250CR	6	1180	-	-	-	-	-
-	CP 250AR	6	1180	-	-	-	-	-

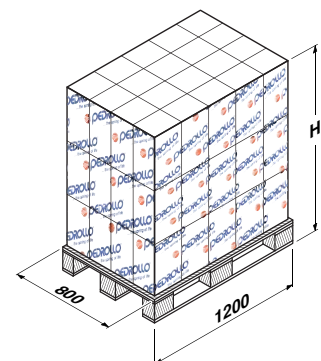



PERFORMANCE RANGE

- Flow rate up to **250 l/min** (15 m³/h)
- Head up to **57 m**

APPLICATION LIMITS

- Manometric suction lift up to **7 m**
- Liquid temperature between **-10 °C** and **+90 °C**
- Ambient temperature between **-10 °C** and **+40 °C**
- Max. working pressure **10 bar**
- Continuous service **S1**

CONSTRUCTION AND SAFETY STANDARDS

EN 60034-1
IEC 60034-1
CEI 2-3



CERTIFICATIONS



INSTALLATION AND USE

Suitable for use with clean water and liquids that are not chemically aggressive towards the materials from which the pump is made. The pumps in this series are specifically intended for use in the civil, industrial and agricultural sectors where their overriding characteristics of sturdiness and reliability are best appreciated. The pump should be installed in an enclosed environment, or at least sheltered from inclement weather.

OPTIONALS AVAILABLE ON REQUEST

- Special mechanical seal
- Other voltages or 60 Hz frequency

GUARANTEE

1 year subject to terms and conditions

CHARACTERISTIC CURVES AND PERFORMANCE DATA

50 Hz n= 2900 1/min HS= 0 m

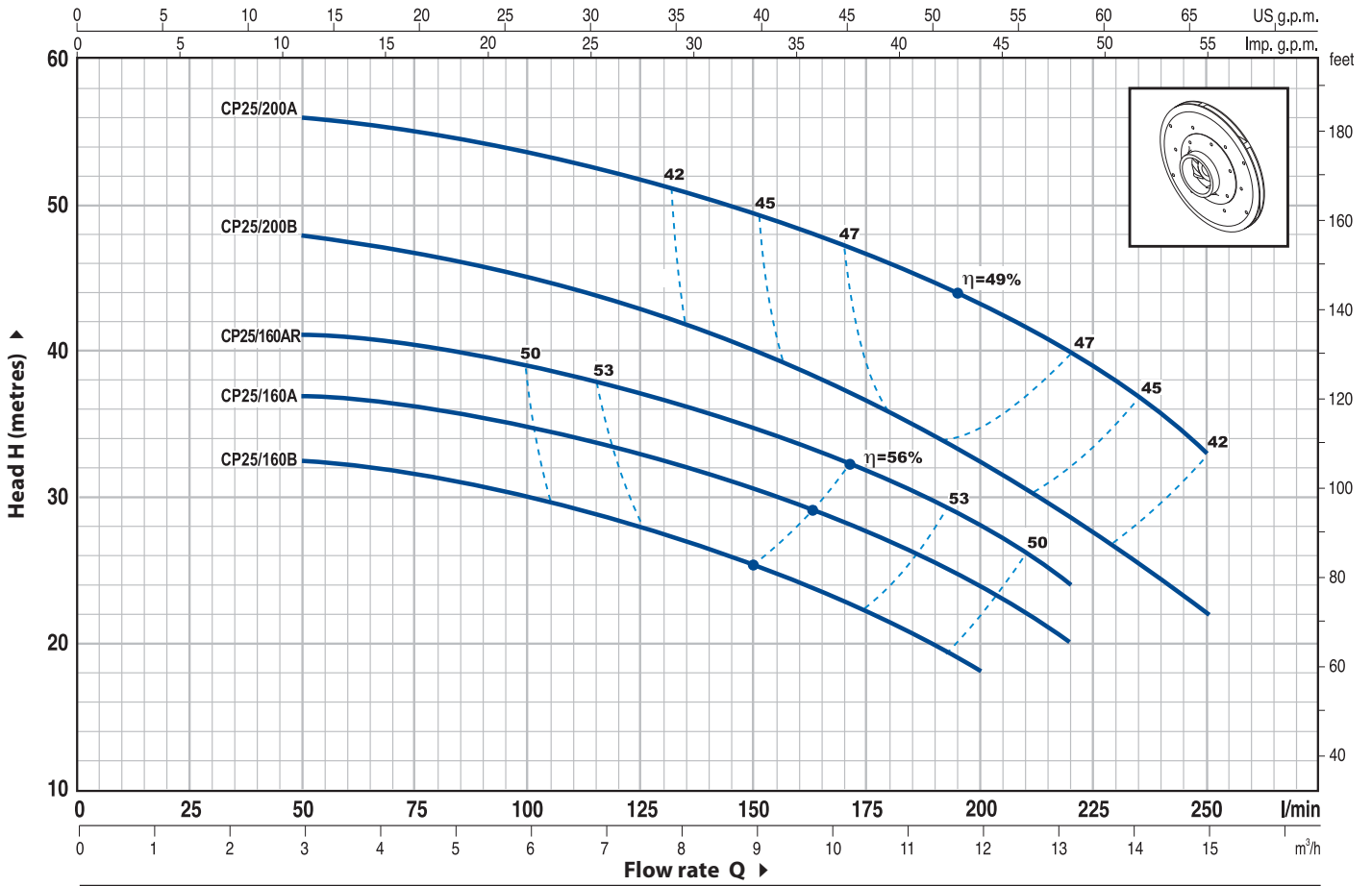

MODEL		POWER		Q	H metres																		
Single-phase	Three-phase	kW	HP		0	3.0	3.6	4.2	4.8	5.4	6.0	6.6	7.5	8.4	9.6	10.8	12.0	13.2	15.0				
				l/min	0	50	60	70	80	90	100	110	125	140	160	180	200	220	250				
CPm 25/160B	CP 25/160B	1.1	1.5	H metres	33	32.5	32	31.5	31	30.5	30	29	28	26.5	24	21.5	18						
CPm 25/160A	CP 25/160A	1.5	2		38	37	36.8	36.5	36	35.5	35	34	33	31.5	29.5	27	24	20					
-	CP 25/160AR	2.2	3		42	41	41	40.5	40	39.5	39	38	37	36	34	31	28	24					
CPm 25/200B	CP 25/200B	2.2	3		49	48	47.5	47	46.5	45.5	45	44	43	41	38.5	36	32	28	22				
-	CP 25/200A	3	4		57	56	55.8	55.5	55	54.5	53.5	53	52	50.5	48.5	46	43.5	40	33				

Q = Flow rate H = Total manometric head HS = Suction height

Tolerance of characteristic curves in compliance with EN ISO 9906 App. A.

POS.	COMPONENT	CONSTRUCTION CHARACTERISTICS					
1	PUMP BODY	Cast iron, made to EN 733 standards, complete with threaded ports in compliance with ISO 228/1					
2	BODY BACKPLATE	Cast iron					
3	IMPELLER	Brass					
4	MOTOR SHAFT	Stainless steel EN 10088-3 - 1.4104					
5	MECHANICAL SEAL	<i>Pump</i>	<i>Seal</i>	<i>Shaft</i>	<i>Materials</i>		
		<i>Model</i>	<i>Model</i>	<i>Diameter</i>	<i>Stationary ring</i>	<i>Rotational ring</i>	<i>Elastomer</i>
		CP 25/160	FN-18	Ø 18 mm	Graphite	Ceramic	NBR
CP 25/200	FN-24	Ø 24 mm	Graphite	Ceramic	NBR		
6	BEARINGS	<i>Pump</i>	<i>Model</i>				
		CP 25/160	6204 ZZ / 6204 ZZ				
		CP 25/200	6206 ZZ - C3 / 6205 ZZ				
7	CAPACITOR	<i>Pump</i>	<i>Capacitance</i>				
		<i>Single-phase</i>	<i>(230 V or 240 V)</i>		<i>(110 V)</i>		
		CPm 25/160B	31.5 µF 450 VL		60 µF 250 VL		
		CPm 25/160A	45 µF 450 VL		80 µF 250 VL		
		CPm 25/200B	70 µF 450 VL		-		
8	ELECTRIC MOTOR	<p>CPm: single-phase 230 V - 50 Hz with thermal overload protector built-in to the winding (up to 1.5 kW).</p> <p>CP: three-phase 230/400 V - 50 Hz.</p> <p>⇒ Pumps fitted with the three-phase motor option offer IE2 (IEC 60034-30) class high performance</p> <p>- Insulation: F class.</p> <p>- Protection: IP 44.</p>					

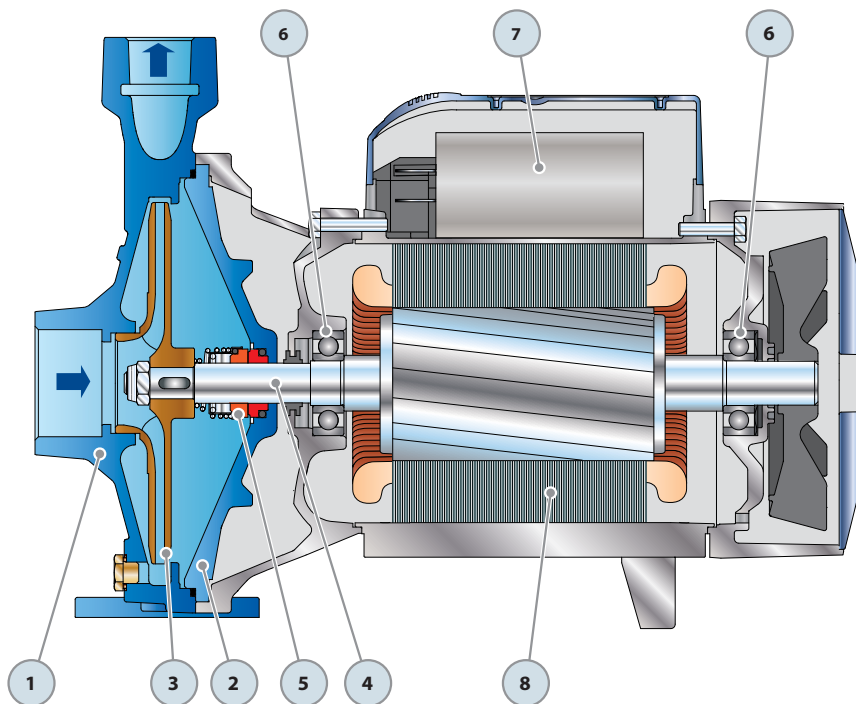

DIMENSIONS AND WEIGHT

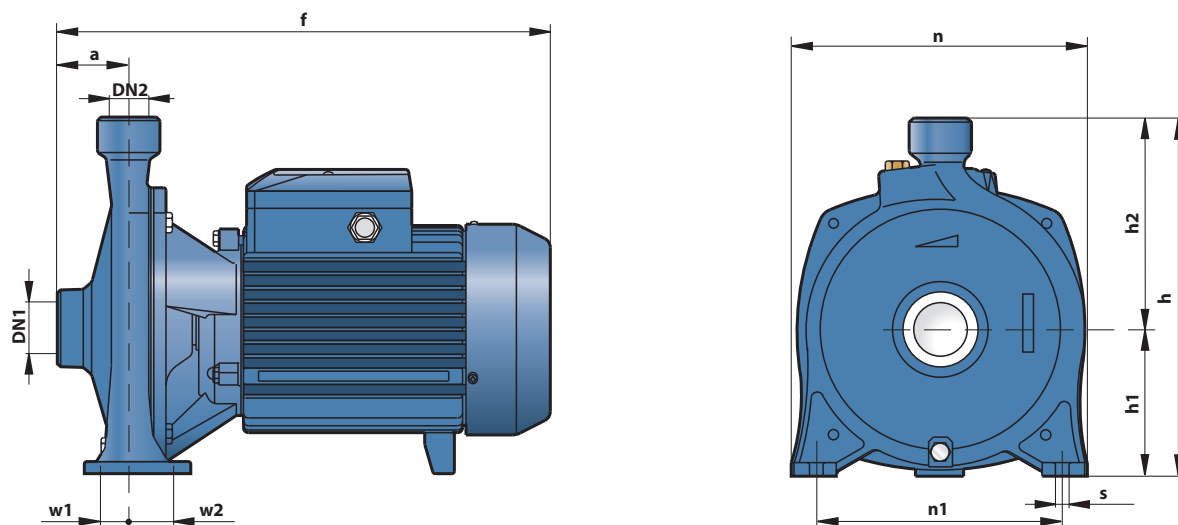

MODEL		PORTS		DIMENSIONS mm										kg	
Single-phase	Three-phase	DN1	DN2	a	f	h	h1	h2	n	n1	w1	w2	s	1~	3~
CPm 25/160B	CP 25/160B	1½"	1"	56	375	260	105	155	206	150	27.5	27.5	10	20.0	18.0
CPm 25/160A	CP 25/160A													21.3	21.3
-	CP 25/160AR													-	21.3
CPm 25/200B	CP 25/200B	60		60	390/365	305	125	180	252	210	23.5	39.5	11	28.5	30.7
-	CP 25/200A				390									-	30.9

ABSORPTION

MODEL	VOLTAGE (single-phase)		
	230 V	240 V	110 V
CPm 25/160B	8.5 A	7.8 A	17.0 A
CPm 25/160A	9.8 A	8.9 A	19.6 A
CPm 25/200B	13.4 A	13.0 A	-

MODEL	VOLTAGE (three-phase)					
	230 V	400 V	690 V	240 V	415 V	720 V
CP 25/160B	5.7 A	3.3 A	1.9 A	5.2 A	3.0 A	1.7 A
CP 25/160A	7.3 A	4.2 A	2.4 A	6.7 A	3.9 A	2.3 A
CP 25/160AR	8.9 A	5.1 A	3.0 A	8.3 A	4.8 A	2.8 A
CP 25/200B	10.5 A	6.0 A	3.5 A	9.6 A	5.6 A	3.3 A
CP 25/200A	12.4 A	7.2 A	4.2 A	11.0 A	6.4 A	3.7 A

PALLETIZATION

MODEL		GROUPAGE			CONTAINER				
Single-phase	Three-phase	n° pumps	H (mm)	kg		n° pumps	H (mm)	kg	
				1~	3~			1~	3~
CPm 25/160B	CP 25/160B	50	1560	1020	920	70	2130	1420	1280
CPm 25/160A	CP 25/160A	50	1560	1090	1040	70	2130	1510	1440
-	CP 25/160AR	50	1560	-	1090	70	2130	-	1510
CPm 25/200B	CP 25/200B	18	1190	530	570	-	-	-	-
-	CP 25/200A	18	1210	-	580	-	-	-	-

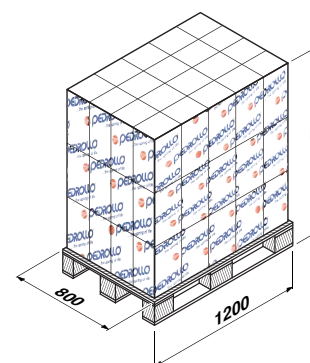

AL-RED

Stainless steel centrifugal pump



PERFORMANCE RANGE

- Maximum flow rate **160 l/min** (9.6 m³/h)
- Maximum head **23 m**

APPLICATION LIMITS

- Manometric suction lift up to **7 m**
- Liquid temperature between **-10 °C** and **+90 °C**
- Ambient temperature between **-10 °C** and **+40 °C**
- Max. working pressure **6 bar**
- Continuous service **S1**

CONSTRUCTION AND SAFETY STANDARDS

EN 60034-1
IEC 60034-1
CEI 2-3



CERTIFICATIONS



INSTALLATION AND USE

Suitable for use with clean water and liquids that are not chemically aggressive towards the materials from which the pump is made. As a result of their construction characteristics, these centrifugal pumps are suitable for use in the domestic, agricultural and industrial sectors. All of the components in contact with the pumped liquid are constructed from stainless steel AISI 304, thus guaranteeing complete hygiene and maximum resistance against corrosion. The pump should be installed in an enclosed environment, or at least sheltered from inclement weather.

PATENTS - TRADE MARKS - MODELS

- Registered Community Design n° 342159-0003.
- AL-RED® is a registered trade mark.

OPTIONALS AVAILABLE ON REQUEST

- Special mechanical seal
- EN 10088-3 - 1.4401 (AISI 316) stainless steel motor shaft
- Other voltages or 60 Hz frequency

GUARANTEE

1 year subject to terms and conditions

CHARACTERISTIC CURVES AND PERFORMANCE DATA

50 Hz n= 2900 1/min HS= 0 m

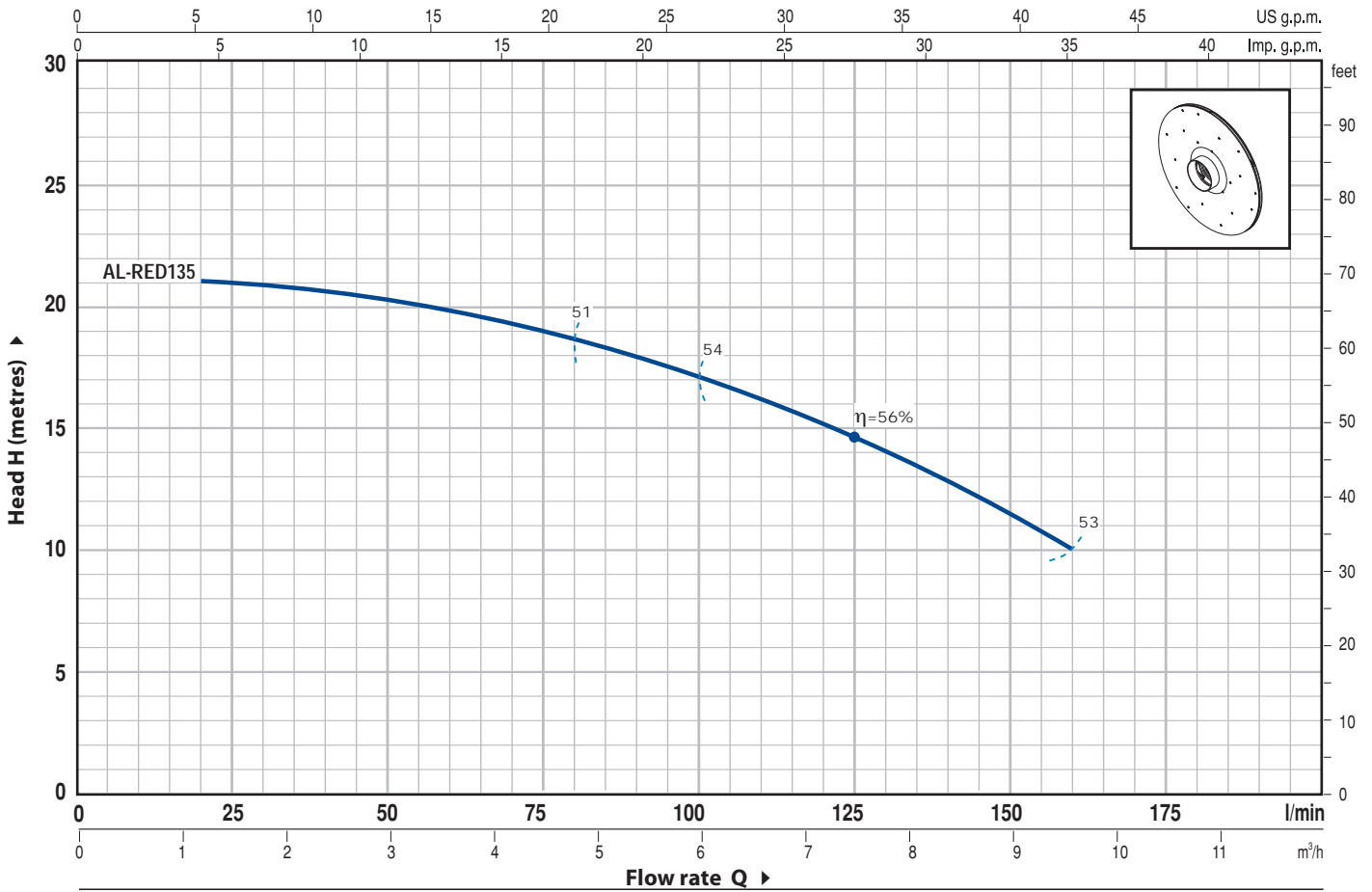

MODEL		POWER		Q	Flow rate									
Single-phase	Three-phase	kW	HP		m ³ /h	0	1.2	2.4	3.6	4.8	6.0	7.2	8.4	9.6
AL-RED 135m	AL-RED 135	0.75	1	H metres	23	21	20.5	20	18.5	17	15	13	10	

Q = Flow rate H = Total manometric head HS = Suction height

Tolerance of characteristic curves in compliance with EN ISO 9906 App. A.

POS.	COMPONENT	CONSTRUCTION CHARACTERISTICS				
1	PUMP BODY	Stainless steel AISI 304, complete with threaded ports in compliance with ISO 228/1				
2	BODY BACKPLATE	Stainless steel AISI 304				
3	IMPELLER	Stainless steel AISI 304				
4	MOTOR SHAFT	Stainless steel EN 10088-3 - 1.4104				
5	MECHANICAL SEAL	<i>Seal</i>	<i>Shaft</i>	<i>Materials</i>		
		<i>Model</i>	<i>Diameter</i>	<i>Stationary ring</i>	<i>Rotational ring</i>	<i>Elastomer</i>
		MG1-14	Ø 14 mm	Ceramic	Graphite	NBR
6	BEARINGS	6203 ZZ / 6203 ZZ				
7	CAPACITOR	<i>Capacitance</i>				
		<i>(230 V or 240 V)</i>	<i>(110 V)</i>			
		20 µF 450 VL	60 µF 300 VL			

- 8 **ELECTRIC MOTOR** **AL-RED 135m**: single-phase 230 V - 50 Hz with thermal overload protector built-in to the winding.
AL-RED 135: three-phase 230/400 V - 50 Hz.
 ⇒ **Pump fitted with the three-phase motor option offers IE2 (IEC 60034-30) class high performance**
 – Insulation: F class.
 – Protection: IP 44.

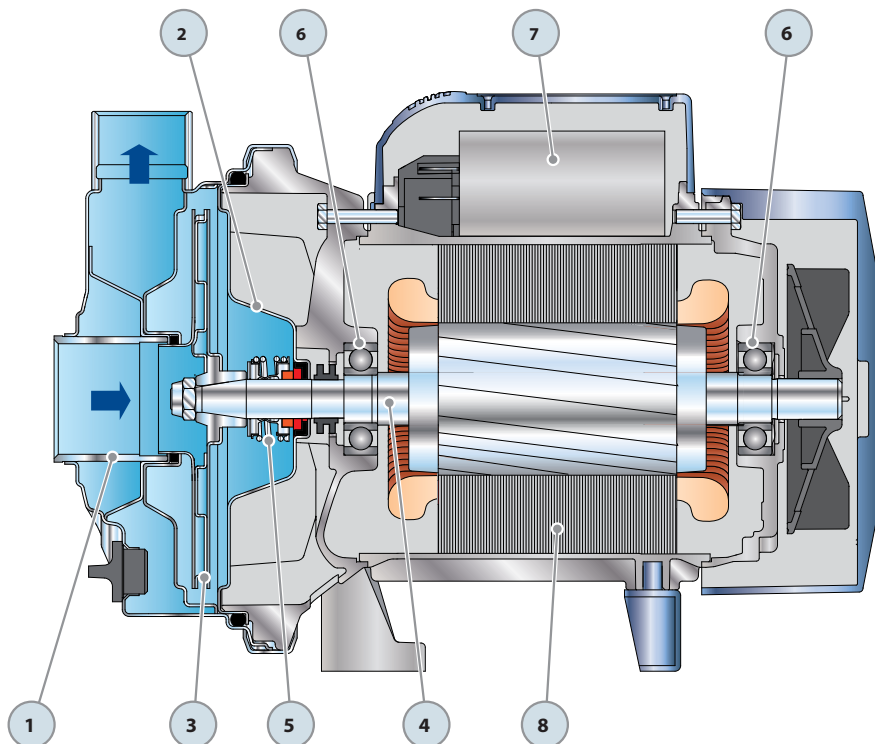

DIMENSIONS AND WEIGHT

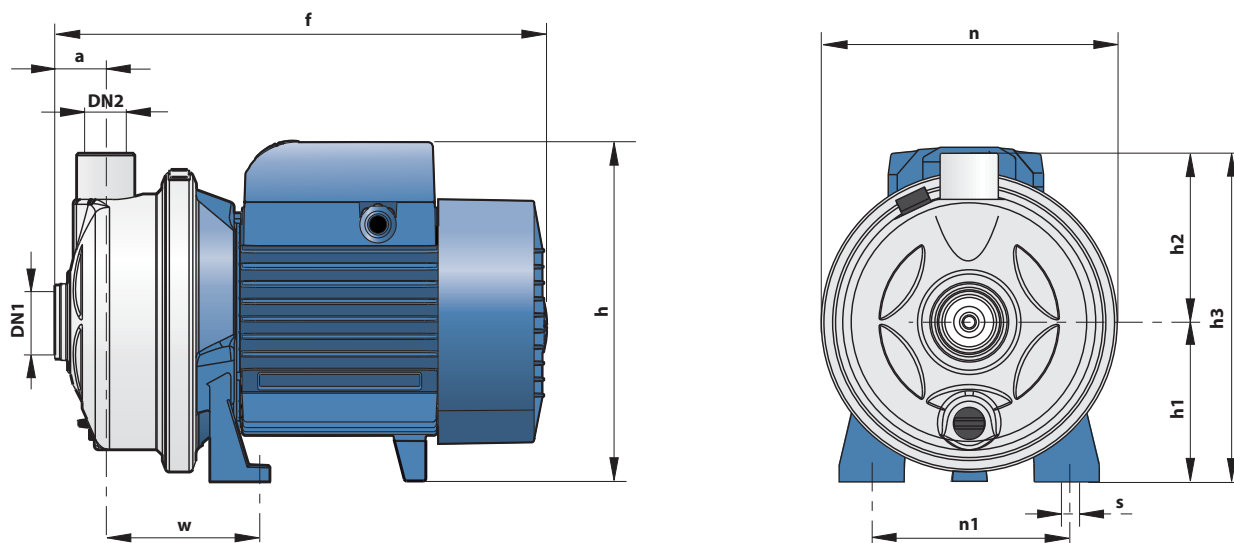

MODEL		PORTS		DIMENSIONS mm										kg	
Single-phase	Three-phase	DN1	DN2	a	f	h	h1	h2	h3	n	n1	w	s	1~	3~
AL-RED 135m	AL-RED 135	1¼"	1"	31.5	295	206	97	103	200	182	115	93	10	9.0	8.9

ABSORPTION

MODEL	VOLTAGE (single-phase)		
	230 V	240 V	110 V
Single-phase			
AL-RED 135m	5.0 A	4.8 A	10.0 A

MODEL	VOLTAGE (three-phase)					
	230 V	400 V	690 V	240 V	415 V	720 V
Three-phase						
AL-RED 135	3.1 A	1.8 A	1.0 A	3.0 A	1.7 A	1.0 A

PALLETIZATION

MODEL		GROUPAGE				CONTAINER			
		n° pumps	H (mm)	kg		n° pumps	H (mm)	kg	
Single-phase	Three-phase			1~	3~			1~	3~
AL-RED 135m	AL-RED 135	70	1310	650	640	112	2020	1030	1020

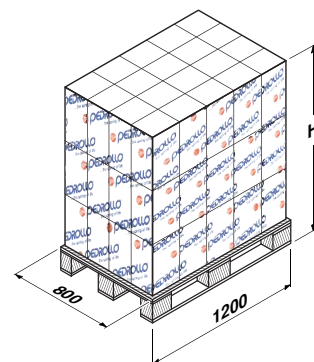

Centrifugal pumps

Medium flow rates



PERFORMANCE RANGE

- Flow rate up to **600 l/min** (36 m³/h)
- Head up to **39 m**

APPLICATION LIMITS

- Manometric suction lift up to **7 m**
- Liquid temperature between **-10 °C** and **+90 °C**
- Ambient temperature up to **+40 °C**
- Max. working pressure:
 - **6 bar** for HF 5-50-51
 - **10 bar** for HF 5M-60-70
- Continuous service **S1**

CONSTRUCTION AND SAFETY STANDARDS

EN 60034-1
IEC 60034-1
CEI 2-3



CERTIFICATIONS



INSTALLATION AND USE

Suitable for use in civil and agricultural applications. The high efficiency and continuous duty capabilities makes these pumps ideal for use in activities such as flood and spray irrigation, drawing water from lakes, rivers and wells, or for any number of different industrial applications where the characteristics of high flow rates and mid to low head are required. The pump should be installed in an enclosed environment, or at least sheltered from inclement weather.

OPTIONALS AVAILABLE ON REQUEST

- Special mechanical seal
- Other voltages or 60 Hz frequency
- IP55 class protection for HF 60, HF 70, HF 5BM, HF 5AM

GUARANTEE

1 year subject to terms and conditions

CHARACTERISTIC CURVES AND PERFORMANCE DATA

50 Hz n= 2900 1/min HS= 0 m

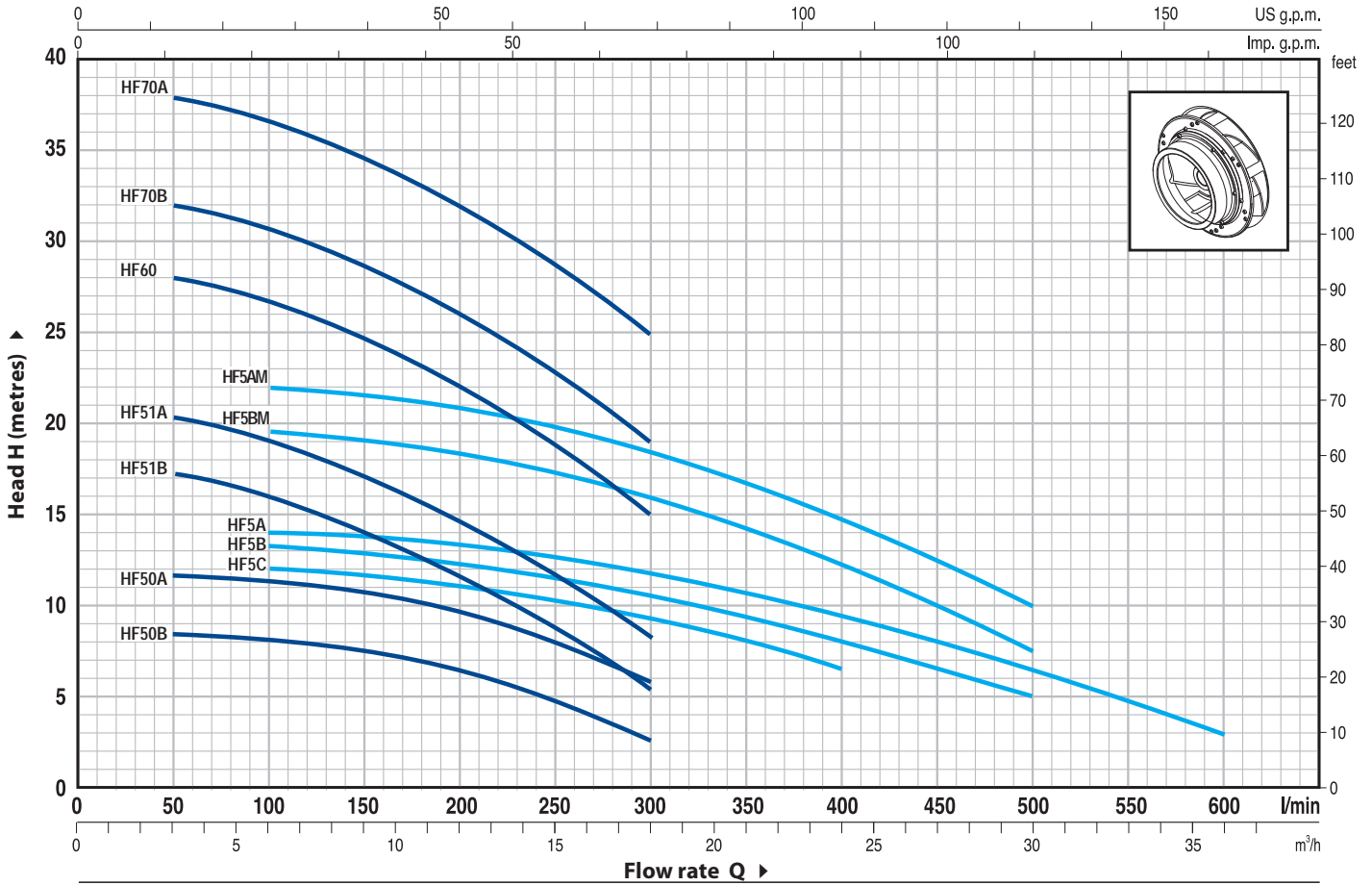

MODEL		POWER		Q	Flow rate (m³/h)													
Single-phase	Three-phase	kW	HP		0	3	6	9	12	15	18	21	24	30	36			
HFm 50B	HF 50B	0.37	0.50	0	0	50	100	150	200	250	300	350	400	500	600			
HFm 50A	HF 50A	0.55	0.75	9	8.5	8.2	7.5	6.3	4.9	2.8								
HFm 51B	HF 51B	0.60	0.85	12	11.5	11.2	10.6	9.6	8	6								
HFm 51A	HF 51A	0.75	1	18.2	17.2	16	14	11.5	9	5.4								
HFm 60	HF 60	1.1	1.5	21.2	20.2	19	17	14.5	11.6	8.4								
HFm 70B	HF 70B	1.5	2	29	28	26.5	24.5	22	18.5	15								
-	HF 70A	2.2	3	33	32	30.5	28.5	26	22.5	19								
HFm 5C	HF 5C	0.60	0.85	39	38	36.5	34.5	32	28.5	25								
HFm 5B	HF 5B	0.75	1	12.5	-	12	11.7	11	10.2	9.2	8	6.5						
HFm 5A	HF 5A	1.1	1.5	13.7	-	13.2	13	12.5	11.6	10.5	9.2	8	5					
HFm 5BM	HF 5BM	1.1	1.5	14.5	-	13.8	13.5	13.2	12.6	11.8	10.5	9.2	6.5	3				
HFm 5AM	HF 5AM	1.5	2	20.2	-	19.2	19	18	17	16	14	12	7.5					
				22.5	-	22	21.5	21	20	18.5	16.6	14.5	10					

Q = Flow rate H = Total manometric head HS = Suction height

Tolerance of characteristic curves in compliance with EN ISO 9906 App. A.

POS.	COMPONENT	CONSTRUCTION CHARACTERISTICS					
1	PUMP BODY	Cast iron, complete with threaded ports in compliance with ISO 228/1					
2	BODY BACKPLATE	Stainless steel AISI 304 (cast iron for HF 60-70-5M)					
3	IMPELLER	Brass					
4	MOTOR SHAFT	Stainless steel EN 10088-3 - 1.4104					
5	MECHANICAL SEAL	<i>Pump</i>	<i>Seal</i>	<i>Shaft</i>	<i>Materials</i>		
		<i>Model</i>	<i>Model</i>	<i>Diameter</i>	<i>Stationary ring</i>	<i>Rotational ring</i>	<i>Elastomer</i>
		HF 50	AR-12	Ø 12 mm	Ceramic	Graphite	NBR
		HF 5-51	AR-14	Ø 14 mm	Ceramic	Graphite	NBR
	HF 5M-60-70	FN-18	Ø 18 mm	Graphite	Ceramic	NBR	
6	BEARINGS	<i>Pump</i>	<i>Model</i>				
		HF 50	6201 ZZ / 6201 ZZ				
		HF 5-51	6203 ZZ / 6203 ZZ				
		HF 5M-60-70	6204 ZZ / 6204 ZZ				
7	CAPACITOR	<i>Pump</i>	<i>Capacitance</i>				
		<i>Single-phase</i>	<i>(230 V or 240 V)</i>		<i>(110 V)</i>		
		HFm 50B	10 µF 450 VL	30 µF 250 VL			
		HFm 50A	14 µF 450 VL	30 µF 250 VL			
		HFm 51B	20 µF 450 VL	60 µF 300 VL			
		HFm 51A	20 µF 450 VL	60 µF 300 VL			
		HFm 60	25 µF 450 VL	60 µF 250 VL			
		HFm 70B	45 µF 450 VL	80 µF 250 VL			
		HFm 5C	16 µF 450 VL	60 µF 300 VL			
		HFm 5B	20 µF 450 VL	60 µF 300 VL			
		HFm 5A	25 µF 450 VL	60 µF 300 VL			
		HFm 5BM	25 µF 450 VL	60 µF 250 VL			
		HFm 5AM	45 µF 450 VL	80 µF 250 VL			
8	ELECTRIC MOTOR	HFm: single-phase 230 V - 50 Hz with thermal overload protector built-in to the winding. HF: three-phase 230/400 V - 50 Hz. ⇒ Pumps fitted with the three-phase motor option offer IE2 (IEC 60034-30) class high performance – Insulation: F class. – Protection: IP 44.					

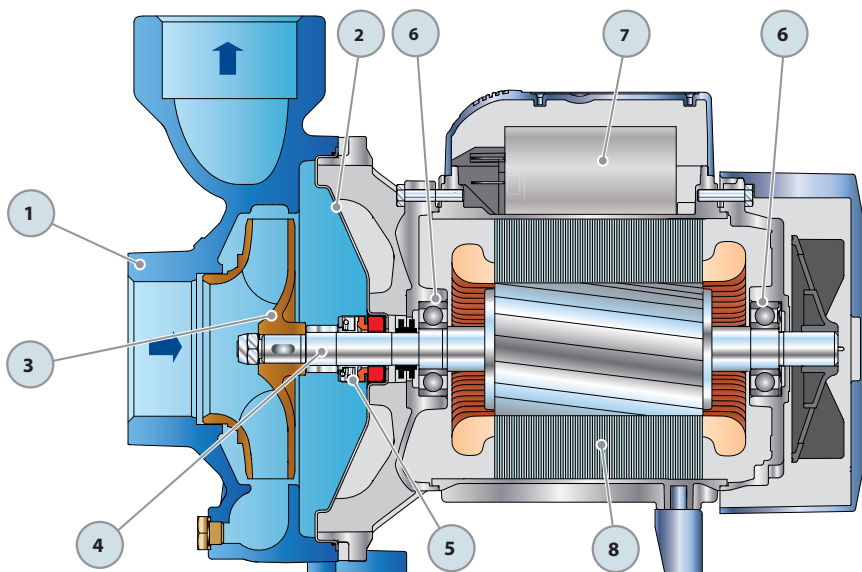

DIMENSIONS AND WEIGHT

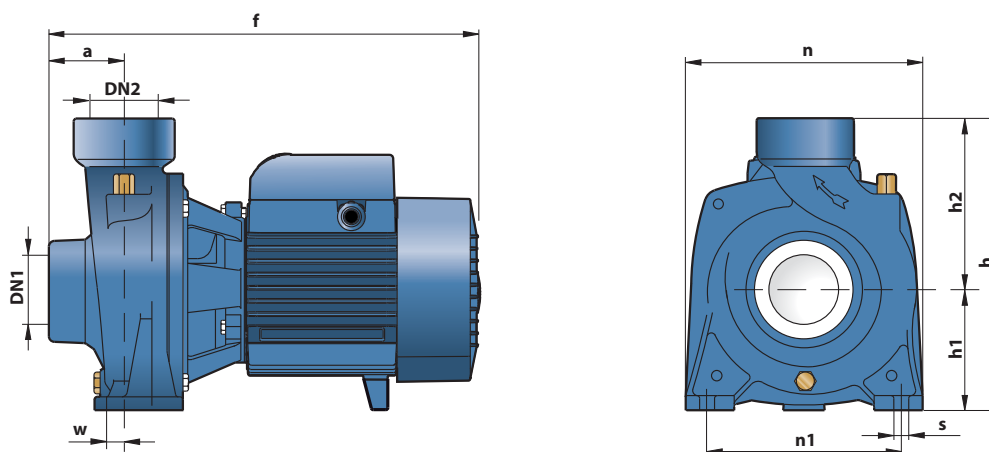

MODEL		PORTS		DIMENSIONS mm									kg			
Single-phase	Three-phase	DN1	DN2	a	f	h	h1	h2	n	n1	w	s	1~	3~		
HFm 50B	HF 50B	1½"	1½"	45	276	200	82	118	165	135	1	10	8.1	7.6		
HFm 50A	HF 50A				283/276								8.7	8.3		
HFm 51B	HF 51B				300								12.9	11.9		
HFm 51A	HF 51A			48.5	373	225	92	133	190	160	4		12	12	13.0	12.0
HFm 60	HF 60														19.0	18.6
HFm 70B	HF 70B														21.8	20.5
-	HF 70A	-	21.9													
HFm 5C	HF 5C	2"	2"	60	332	238	97	141	196	14	11	14.5	13.3			
HFm 5B	HF 5B											14.5	13.3			
HFm 5A	HF 5A			51	386	260	110	150	206	160		1	15.3	14.9		
HFm 5BM	HF 5BM												19.5	18.9		
HFm 5AM	HF 5AM												22.0	20.9		

ABSORPTION

MODEL	VOLTAGE (single-phase)		
	230 V	240 V	110 V
Single-phase			
HFm 50B	2.8 A	2.6 A	5.6 A
HFm 50A	3.8 A	3.5 A	7.6 A
HFm 51B	4.7 A	4.6 A	9.2 A
HFm 51A	5.6 A	5.3 A	11.2 A
HFm 60	8.0 A	7.6 A	16.0 A
HFm 70B	10.0 A	9.0 A	20.0 A
HFm 5C	4.2 A	3.8 A	8.4 A
HFm 5B	4.9 A	4.5 A	10.0 A
HFm 5A	6.2 A	5.7 A	12.5 A
HFm 5BM	7.7 A	7.1 A	14.8 A
HFm 5AM	9.8 A	9.0 A	19.6 A

MODEL	VOLTAGE (three-phase)					
	230 V	400 V	690 V	240 V	415 V	720 V
Three-phase						
HF 50B	2.1 A	1.2 A	0.7 A	2.1 A	1.2 A	0.7 A
HF 50A	3.0 A	1.7 A	1.0 A	3.0 A	1.75 A	1.0 A
HF 51B	3.6 A	2.1 A	1.2 A	3.8 A	2.2 A	1.3 A
HF 51A	4.4 A	2.5 A	1.5 A	4.0 A	2.3 A	1.3 A
HF 60	5.7 A	3.3 A	1.9 A	5.5 A	3.2 A	1.8 A
HF 70B	7.4 A	4.3 A	2.5 A	7.1 A	4.1 A	2.4 A
HF 70A	9.5 A	5.5 A	3.2 A	9.1 A	5.3 A	3.1 A
HF 5C	3.5 A	2.0 A	1.15 A	3.3 A	1.9 A	1.1 A
HF 5B	3.6 A	2.1 A	1.2 A	3.5 A	2.0 A	1.2 A
HF 5A	4.0 A	2.3 A	1.35 A	3.6 A	2.1 A	1.2 A
HF 5BM	5.7 A	3.3 A	1.9 A	5.5 A	3.2 A	1.8 A
HF 5AM	7.1 A	4.1 A	2.4 A	6.5 A	3.7 A	2.1 A

PALLETIZATION

MODEL		GROUPAGE				CONTAINER			
Single-phase	Three-phase	n° pumps	H (mm)	kg		n° pumps	H (mm)	kg	
				1~	3~			1~	3~
HFm 50B	HF 50B	75	1290	630	590	135	2210	1110	1050
HFm 50A	HF 50A	75	1290	670	640	135	2210	1190	1140
HFm 51B	HF 51B	70	1430	920	850	112	2200	1460	1350
HFm 51A	HF 51A	70	1430	930	860	112	2200	1480	1360
HFm 60	HF 60	36	1470	700	690	54	2130	1050	1020
HFm 70B	HF 70B	36	1470	800	760	54	2130	1200	1130
-	HF 70A	36	1470	-	810	54	2130	-	1200
HFm 5C	HF 5C	60	1540	890	820	84	2100	1240	1140
HFm 5B	HF 5B	60	1540	890	820	84	2100	1240	1140
HFm 5A	HF 5A	60	1540	940	910	84	2100	1300	1270
HFm 5BM	HF 5BM	50	1540	990	960	70	2100	1380	1340
HFm 5AM	HF 5AM	50	1540	1120	1060	70	2100	1560	1480

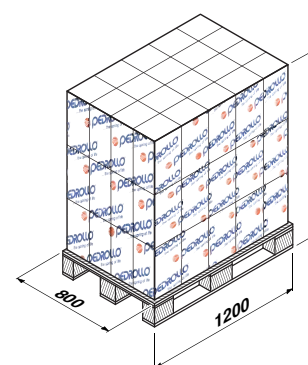

Centrifugal pumps

High flow rates



PERFORMANCE RANGE

- Flow rate up to **2200 l/min** (132 m³/h)
- Head up to **24.5 m**

APPLICATION LIMITS

- Manometric suction lift up to **7 m**
- Liquid temperature between **-10 °C** and **+90 °C**
- Ambient temperature up to **+40 °C**
- Max. working pressure:
 - **6 bar** for HF 4
 - **10 bar** for HF 6-8-20-30
- Continuous service **S1**

CONSTRUCTION AND SAFETY STANDARDS

EN 60034-1
IEC 60034-1
CEI 2-3



CERTIFICATIONS



INSTALLATION AND USE

Suitable for use in civil and agricultural applications. The high efficiency and continuous duty capabilities makes these pumps ideal for use in activities such as flood and spray irrigation, drawing water from lakes, rivers and wells, or for any number of different industrial applications where the characteristics of high flow rates and mid to low head are required. The pump should be installed in an enclosed environment, or at least sheltered from inclement weather.

OPTIONALS AVAILABLE ON REQUEST

- Special mechanical seal
- Other voltages or 60 Hz frequency

GUARANTEE

1 year subject to terms and conditions

CHARACTERISTIC CURVES AND PERFORMANCE DATA

50 Hz n= 2900 1/min HS= 0 m

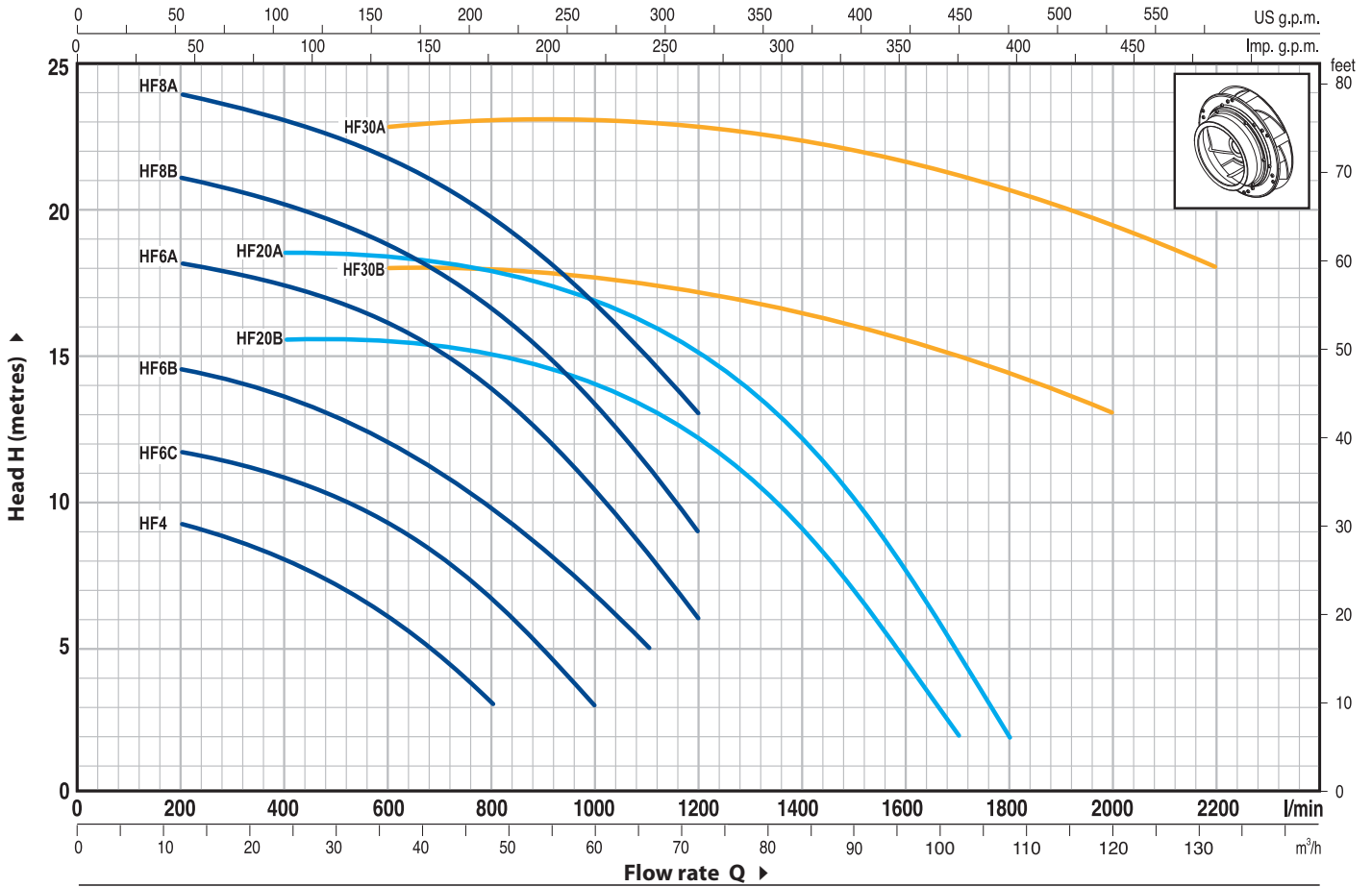

MODEL		POWER		Q	H metres																			
Single-phase	Three-phase	kW	HP		m³/h	0	12	18	24	30	36	42	48	54	60	66	72	84	96	102	108	120	132	
				l/min	0	200	300	400	500	600	700	800	900	1000	1100	1200	1400	1600	1700	1800	2000	2200		
HFm 4	HF 4	0.75	1		10	9.3	8.7	8	7	6	4.7	3												
HFm 6C	HF 6C	1.1	1.5		11.9	11.7	11.3	10.7	10.2	9.2	8	6.7	5	3										
HFm 6B	HF 6B	1.5	2		14.7	14.5	14	13.5	12.8	12	11	9.7	8.2	6.7	5									
-	HF 6A	2.2	3		18.5	18.1	17.8	17.2	16.8	16	15	13.8	12.2	10.5	8.3	6								
-	HF 8B	3	4		21.5	21	20.7	20	19.5	18.8	17.8	16.5	15	13.5	11.2	9								
-	HF 8A	4	5.5		24.5	24	23.5	23	22.5	21.8	20.8	19.5	18.3	16.8	15	13								
-	HF 20B	3	4		16	-	-	15.5	15.4	15.3	15.2	15	14.5	14	13	12	9	4.8	2					
-	HF 20A	4	5.5		19	-	-	18.5	18.4	18.3	18.2	18	17.5	17	16.2	15.2	12	7.8	5	2				
-	HF 30B	5.5	7.5		18	-	-	-	-	18	18	18	18	18	17.5	17	16.5	15.5	15	14.5	13			
-	HF 30A	7.5	10		23	-	-	-	-	23	23	23	23	23	22.5	22.5	22.5	22	21.5	21	19.5	18		

Q = Flow rate H = Total manometric head HS = Suction height

Tolerance of characteristic curves in compliance with EN ISO 9906 App. A.

POS.	COMPONENT	CONSTRUCTION CHARACTERISTICS					
1	PUMP BODY	Cast iron, complete with threaded ports in compliance with ISO 228/1					
2	BODY BACKPLATE	Cast iron (stainless steel AISI 304 for HF 4)					
3	IMPELLER	Brass for HF 4, HF 6, HF 8, HF 20 Cast iron for HF 30					
4	MOTOR SHAFT	Stainless steel EN 10088-3 - 1.4104					
5	MECHANICAL SEAL	<i>Pump</i>	<i>Seal</i>	<i>Shaft</i>	<i>Materials</i>		
		<i>Model</i>	<i>Model</i>	<i>Diameter</i>	<i>Stationary ring</i>	<i>Rotational ring</i>	<i>Elastomer</i>
		HF 4	AR-14	Ø 14 mm	Ceramic	Graphite	NBR
		HF 6	FN-18	Ø 18 mm	Graphite	Ceramic	NBR
		HF 8-20	FN-20	Ø 20 mm	Graphite	Ceramic	NBR
		HF 30	FN-24	Ø 24 mm	Graphite	Ceramic	NBR
6	BEARINGS	<i>Pump</i>	<i>Model</i>				
		HF 4	6203 ZZ / 6203 ZZ				
		HF 6	6304 ZZ / 6204 ZZ				
		HF 8B-20B	6206 ZZ - C3 / 6205 ZZ				
		HF 8A-20A	6306 ZZ - C3 / 6206 ZZ - C3				
		HF 30	6307 ZZ - C3 / 6206 ZZ - C3				
7	CAPACITOR	<i>Pump</i>	<i>Capacitance</i>				
		<i>Single-phase</i>	<i>(230 V or 240 V)</i>		<i>(110 V)</i>		
		HFm 4	20 µF 450 VL	60 µF 300 VL			
		HFm 6C	31.5 µF 450 VL	60 µF 250 VL			
		HFm 6B	45 µF 450 VL	80 µF 250 VL			
8	ELECTRIC MOTOR	HFm: single-phase 230 V - 50 Hz with thermal overload protector built-in to the winding. HF: three-phase 230/400 V - 50 Hz up to 4 kW, 400/690 V - 50 Hz from 5.5 to 7.5 kW ► Pumps fitted with the three-phase motor option offer IE2 (IEC 60034-30) class high performance – Insulation: F class. – Protection: IP 44.					

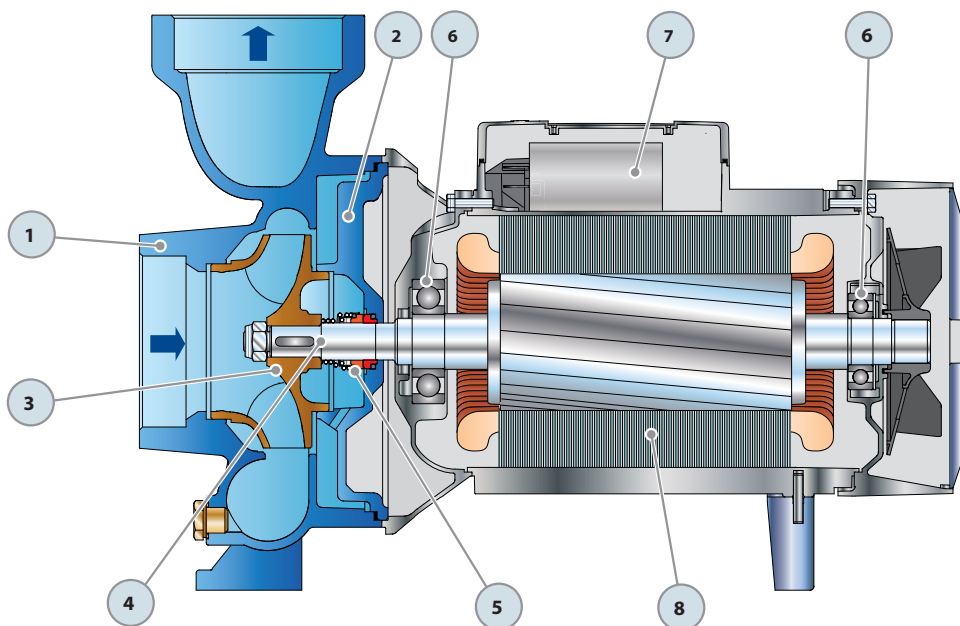

DIMENSIONS AND WEIGHT

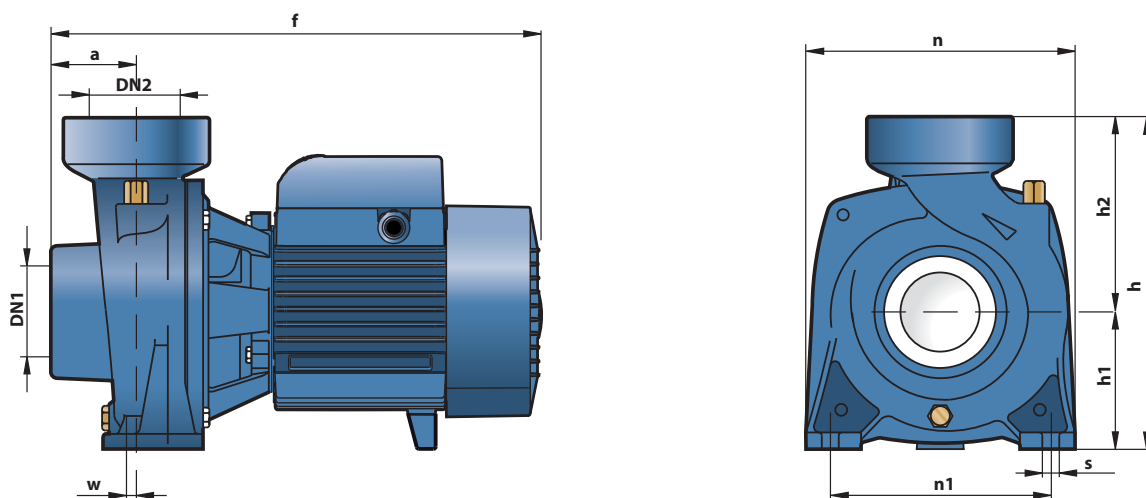

MODEL		PORTS		DIMENSIONS mm									kg	
Single-phase	Three-phase	DN1	DN2	a	f	h	h1	h2	n	n1	w	s	1~	3~
HFm 4	HF 4	2½"	2½"	55	323	240	97	143	198	155	0	10	14.5	13.2
HFm 6C	HF 6C	3"	3"	68	411	312	120	192	240	190	6	12	25.5	24.2
HFm 6B	HF 6B												26.5	25.5
-	HF 6A	4"	4"	80	435	312	132	180	245	190	30	14	-	26.7
-	HF 8B												-	35.0
-	HF 8A												-	40.0
-	HF 20B												-	35.0
-	HF 20A												-	40.0
-	HF 30B	82	585	370	160	210	292	212	190	30	14	-	60.9	
-	HF 30A											-	65.2	

ABSORPTION

MODEL	VOLTAGE (single-phase)		
	230 V	240 V	110 V
Single-phase	230 V	240 V	110 V
HFm 4	5.9 A	5.3 A	11.8 A
HFm 6C	8.8 A	8.0 A	17.6 A
HFm 6B	10.8 A	9.8 A	21.6 A

MODEL	VOLTAGE (three-phase)					
	230 V	400 V	690 V	240 V	415 V	720 V
Three-phase	230 V	400 V	690 V	240 V	415 V	720 V
HF 4	4.3 A	2.5 A	1.4 A	4.0 A	2.3 A	1.3 A
HF 6C	6.2 A	3.6 A	2.1 A	6.0 A	3.5 A	2.0 A
HF 6B	8.0 A	4.6 A	2.7 A	7.4 A	4.3 A	2.5 A
HF 6A	9.0 A	5.2 A	3.0 A	8.3 A	4.8 A	2.8 A
HF 8B	11.8 A	6.8 A	3.9 A	12.1 A	7.0 A	4.0 A
HF 8A	15.8 A	9.1 A	5.3 A	15.2 A	8.8 A	5.1 A
HF 20B	13.0 A	7.5 A	4.3 A	13.4 A	7.7 A	4.4 A
HF 20A	15.2 A	8.8 A	5.1 A	15.3 A	8.8 A	5.1 A
HF 30B	21.3 A	12.3 A	7.1 A	20.4 A	11.8 A	6.8 A
HF 30A	28.6 A	16.5 A	9.5 A	27.5 A	15.9 A	9.2 A

PALLETIZATION

MODEL		GROUPAGE				CONTAINER			
Single-phase	Three-phase	n° pumps	H (mm)	kg		n° pumps	H (mm)	kg	
				1~	3~			1~	3~
HFm 4	HF 4	60	1540	890	830	84	2100	1240	1150
HFm 6C	HF 6C	36	1480	940	890	54	2150	1400	1330
HFm 6B	HF 6B	36	1480	970	940	54	2150	1450	1400
-	HF 6A	36	1480	-	980	54	2150	-	1460
-	HF 8B	18	1430	-	650	24	1860	-	860
-	HF 8A	18	1430	-	740	24	1860	-	980
-	HF 20B	18	1430	-	650	24	1860	-	860
-	HF 20A	18	1430	-	740	24	1860	-	980
-	HF 30B	12	1570	-	750	16	2040	-	990
-	HF 30A	12	1570	-	800	16	2040	-	1060

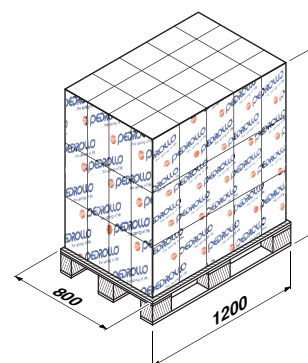



PERFORMANCE RANGE

- Flow rate up to **1200 l/min** (72 m³/h)
- Head up to **22.5 m**

APPLICATION LIMITS

- Manometric suction lift up to **7 m**
- Liquid temperature between **-10 °C** and **+90 °C**
- Ambient temperature up to **+40 °C**
- Max. working pressure: **10 bar**
- Continuous service **S1**

CONSTRUCTION AND SAFETY STANDARDS

EN 60034-1
IEC 60034-1
CEI 2-3



CERTIFICATIONS



INSTALLATION AND USE

The performance and mechanical dimensions of the NF series pumps have been specifically designed for use in the civil and agricultural sectors. As a result of their high efficiency and continuous duty capabilities, they are recommended for use in applications such as flood and spray irrigation, drawing water from lakes, rivers and wells, and for generally transferring liquids. The pump should be installed in an enclosed environment, or at least sheltered from inclement weather.

OPTIONALS AVAILABLE ON REQUEST

- Special mechanical seal
- Other voltages or 60 Hz frequency

GUARANTEE

1 year subject to terms and conditions

CHARACTERISTIC CURVES AND PERFORMANCE DATA

50 Hz n= 2900 1/min HS= 0 m

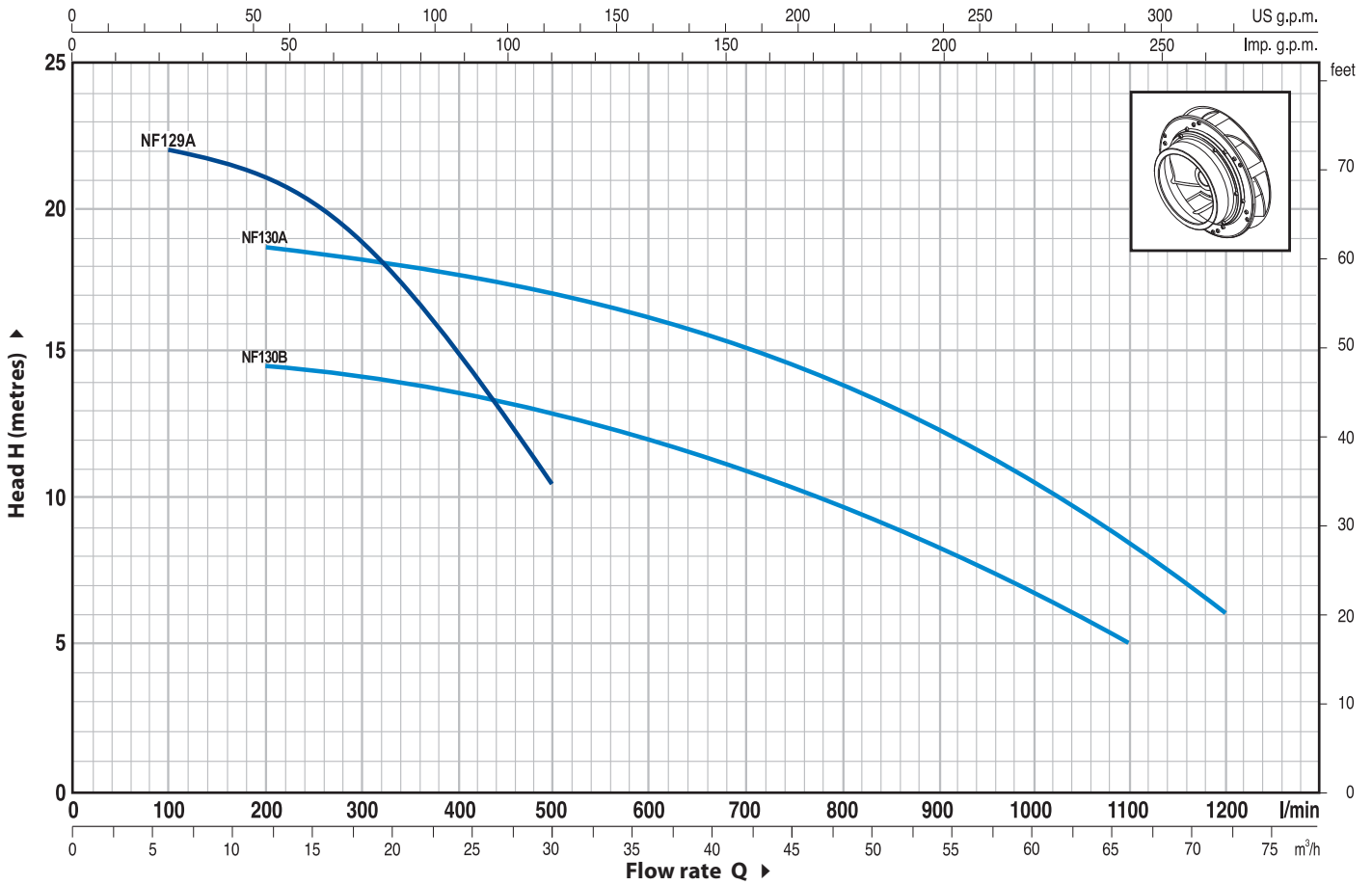

MODEL		POWER		Q	m ³ /h																
Single-phase	Three-phase	kW	HP		0	6	9	12	15	18	21	24	30	36	42	48	54	60	66	72	
NFm 129A	NF 129A	1.5	2	H metres	22.5	22	21.5	21	20	18.5	16.6	14.5	10								
NFm 130B	NF 130B	1.5	2		14.7	-	-	14.5	14.2	14	13.7	13.5	13.2	12	11	9.7	8.2	6.7	5		
-	NF 130A	2.2	3		18.5	-	-	18.1	18	17.8	17.5	17.2	16.8	16	15	13.8	12.2	10.5	8.3	6	

Q = Flow rate H = Total manometric head HS = Suction height

Tolerance of characteristic curves in compliance with EN ISO 9906 App. A.

POS.	COMPONENT	CONSTRUCTION CHARACTERISTICS				
1	PUMP BODY	Cast iron, complete with flanged suction and delivery ports in compliance with ISO 228/1				
2	BODY BACKPLATE	Cast iron				
3	IMPELLER	Brass				
4	MOTOR SHAFT	Stainless steel EN 10088-3 - 1.4104				
5	MECHANICAL SEAL	<i>Seal</i>	<i>Shaft</i>	<i>Materials</i>		
		<i>Model</i>	<i>Diameter</i>	<i>Stationary ring</i>	<i>Rotational ring</i>	<i>Elastomer</i>
		FN-18	Ø 18 mm	Graphite	Ceramic	NBR
6	BEARINGS	<i>Pump</i>	<i>Model</i>			
		NF 129	6204 ZZ / 6204 ZZ			
		NF 130	6304 ZZ / 6204 ZZ			
7	CAPACITOR	<i>Capacitance</i>				
		<i>(230 V or 240 V)</i>	<i>(110 V)</i>			
		45 µF 450 VL	80 µF 250 VL			
8	ELECTRIC MOTOR	<p>NFm: single-phase 230 V - 50 Hz with thermal overload protector built-in to the winding.</p> <p>NF: three-phase 230/400 V - 50 Hz.</p> <p>➔ Pumps fitted with the three-phase motor option offer IE2 (IEC 60034-30) class high performance</p> <ul style="list-style-type: none"> - Insulation: F class. - Protection: IP 44. 				

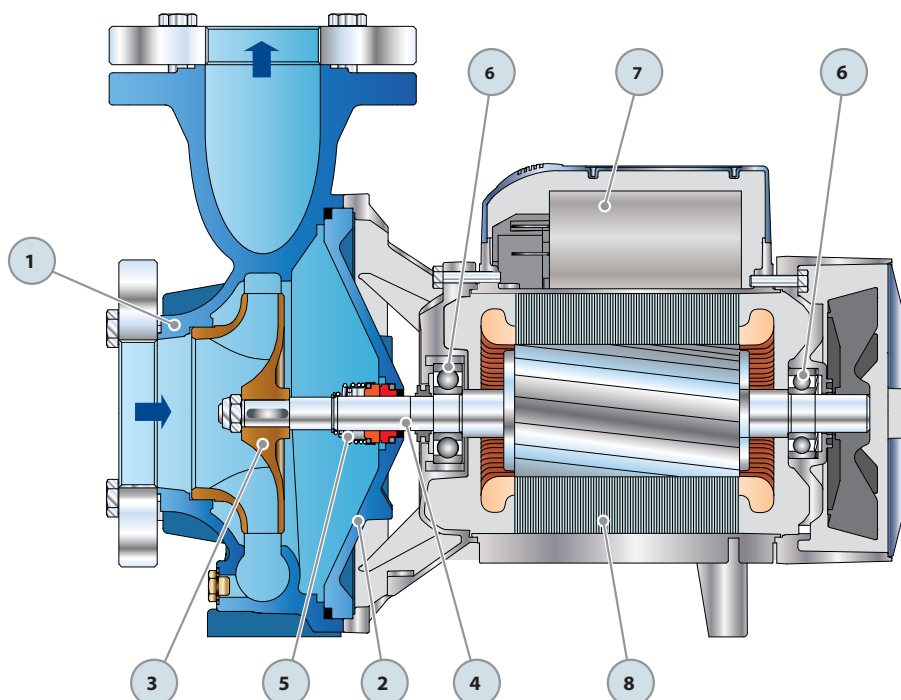

DIMENSIONS AND WEIGHT

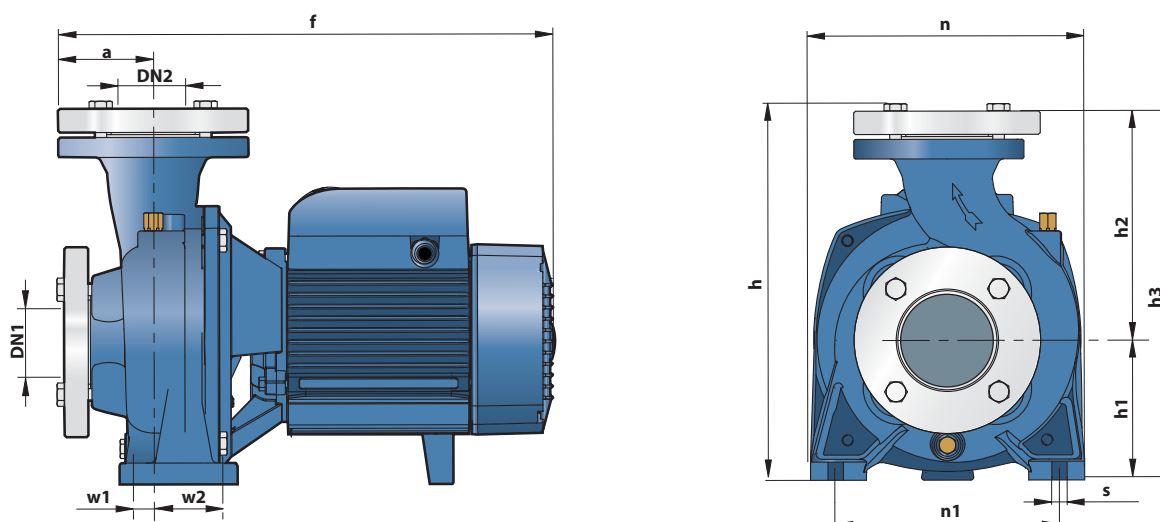

MODEL		PORTS		DIMENSIONS mm											kg*	
Single-phase	Three-phase	DN1	DN2	a	f	h	h1	h2	h3	n	n1	w1	w2	s	1~	3~
NFm 129A	NF 129A	2"	2"	56	398	276	110	159	269	206	160	1	62	11	25.0	23.7
NFm 130B	NF 130B	3"	3"	71	420	320	120	193	313	240	190	6	66	12	31.6	30.7
-	NF 130A														-	32.6

(*weight includes counterflanges)

ABSORPTION

MODEL	VOLTAGE (single-phase)		
	230 V	240 V	110 V
Single-phase	230 V	240 V	110 V
NFm 129A	9.8 A	9.0 A	19.6 A
NFm 130B	10.8 A	9.8 A	21.6 A

MODEL	VOLTAGE (three-phase)					
	230 V	400 V	690 V	240 V	415 V	720 V
Three-phase	230 V	400 V	690 V	240 V	415 V	720 V
NF 129A	7.1 A	4.1 A	2.4 A	6.5 A	3.7 A	2.1 A
NF 130B	8.0 A	4.6 A	2.7 A	7.4 A	4.3 A	2.5 A
NF 130A	9.0 A	5.2 A	3.0 A	8.3 A	4.8 A	2.8 A

PALLETIZATION

MODEL		GROUPAGE				CONTAINER			
		n° pumps	H (mm)	kg		n° pumps	H (mm)	kg	
Single-phase	Three-phase			1~	3~			1~	3~
NFm 129A	NF 129A	36	1430	910	870	54	2080	1360	1300
NFm 130B	NF 130B	36	1430	1160	1130	54	2080	1730	1680
-	NF 130A	36	1430	-	1170	54	2080	-	1750

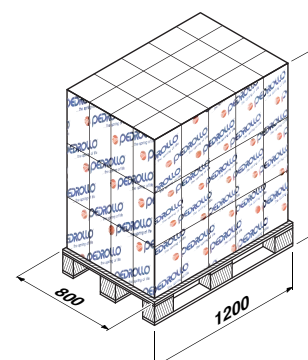



PERFORMANCE RANGE

- Flow rate up to **350 l/min** (21 m³/h)
- Head up to **20 m**

APPLICATION LIMITS

- Manometric suction lift up to **7 m**
- Liquid temperature between **-10 °C** and **+90 °C**
(up to +40 for the version with the technopolymer impeller)
- Ambient temperature between **-10 °C** and **+40 °C**
- Max. working pressure **6 bar**
- Passage of suspended solids up to **Ø 10 mm**
- Continuous service **S1**

CONSTRUCTION AND SAFETY STANDARDS

EN 60034-1
IEC 60034-1
CEI 2-3



CERTIFICATIONS



INSTALLATION AND USE

Suitable for use with liquids that are not chemically aggressive towards the materials from which the pump is made.

The open impeller design allows **liquids containing relatively high levels of impurities** to be pumped without the risk of the impeller clogging. As a result of these characteristics the NGA series pumps are used specifically in industry and for transferring water from canals, rivers, reservoirs, tanks, etc.

The pump should be installed in an enclosed environment, or at least sheltered from inclement weather.

OPTIONALS AVAILABLE ON REQUEST

- Pump with technopolymer impeller
- Special mechanical seal
- Other voltages or 60 Hz frequency

GUARANTEE

1 year subject to terms and conditions

CHARACTERISTIC CURVES AND PERFORMANCE DATA

50 Hz n= 2900 1/min HS= 0 m

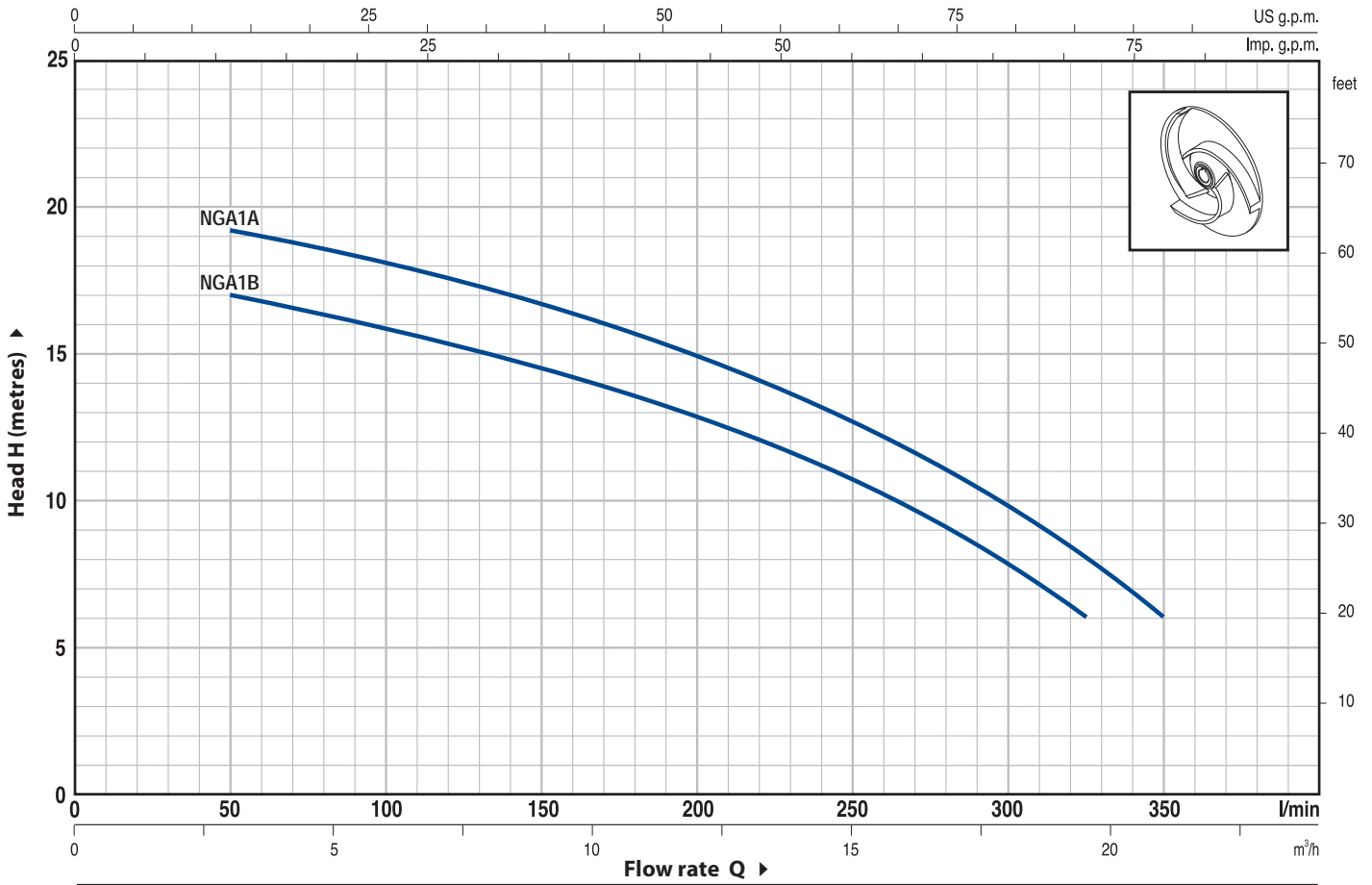

MODEL		POWER		Q	0	3	6	9	12	15	18	19.5	21
Single-phase	Three-phase	kW	HP		0	50	100	150	200	250	300	325	350
NGAm 1B	NGA 1B	0.55	0.75	H metres	18	17	16	14.5	13	10.5	8	6	
NGAm 1A	NGA 1A	0.75	1		20	19.5	18	16.5	15	12.5	10	8	6

Q = Flow rate H = Total manometric head HS = Suction height

Tolerance of characteristic curves in compliance with EN ISO 9906 App. A.

POS.	COMPONENT	CONSTRUCTION CHARACTERISTICS				
1	PUMP BODY	Cast iron, complete with threaded ports in compliance with ISO 228/1				
2	BODY BACKPLATE	Stainless steel AISI 304				
3	IMPELLER	Open impeller in stainless steel 316				
4	MOTOR SHAFT	Stainless steel EN 10088-3 - 1.4104				
5	MECHANICAL SEAL	<i>Seal</i>	<i>Shaft</i>	<i>Materials</i>		
		<i>Model</i>	<i>Diameter</i>	<i>Stationary ring</i>	<i>Rotational ring</i>	<i>Elastomer</i>
		AR-14	Ø 14 mm	Ceramic	Graphite	NBR
6	BEARINGS	6203 ZZ / 6203 ZZ				
7	CAPACITOR	<i>Pump</i>	<i>Capacitance</i>			
		<i>Single-phase</i>	<i>(230 V or 240 V)</i>	<i>(110 V)</i>		
		NGAm 1B	16 µF 450 VL	60 µF 300 VL		
		NGAm 1A	20 µF 450 VL	60 µF 300 VL		
8	ELECTRIC MOTOR	<p>NGAm: single-phase 230 V - 50 Hz with thermal overload protector built-in to the winding.</p> <p>NGA: three-phase 230/400 V - 50 Hz.</p> <p>⇒ Pumps fitted with the three-phase motor option offer IE2 (IEC 60034-30) class high performance</p> <ul style="list-style-type: none"> - Insulation: F class. - Protection: IP 44. 				

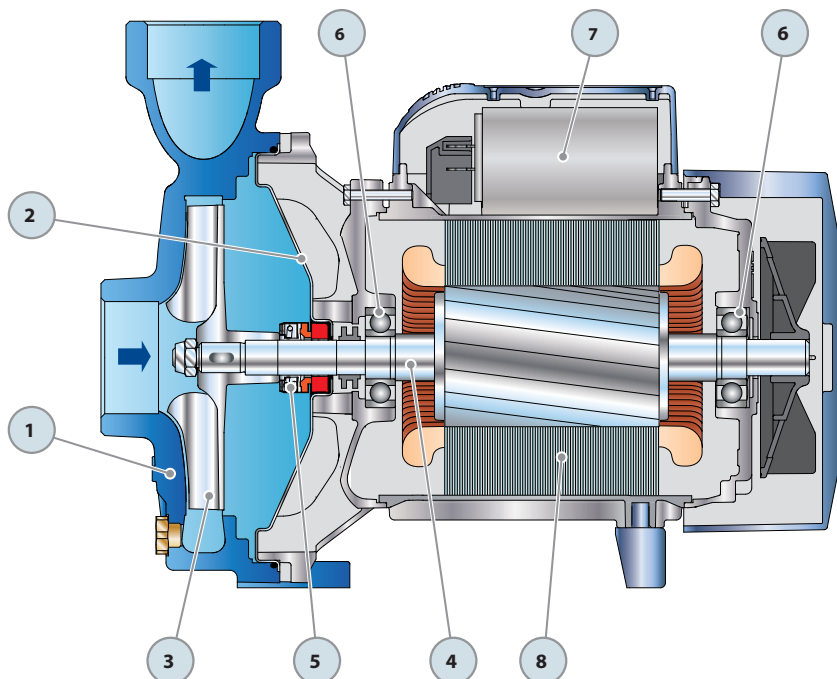

DIMENSIONS AND WEIGHT

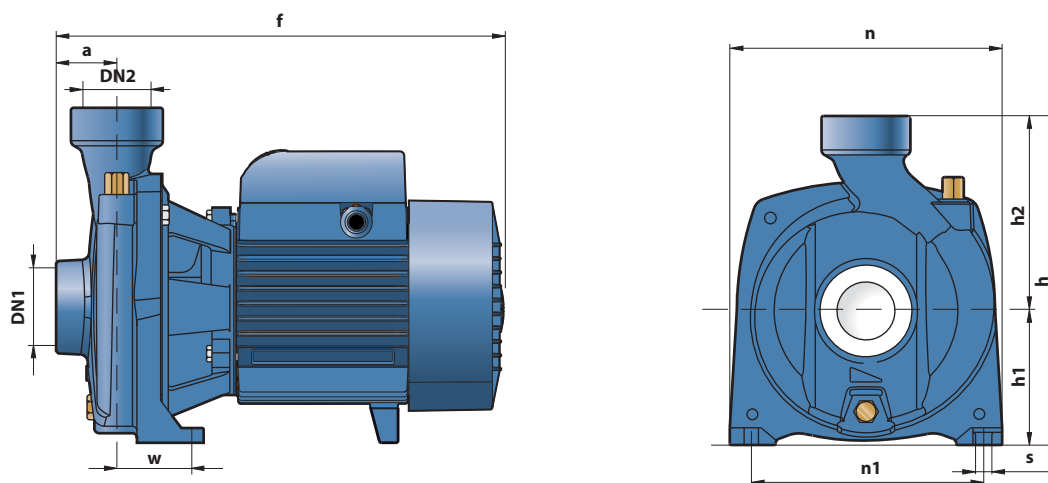

MODEL		PORTS		DIMENSIONS mm									kg	
Single-phase	Three-phase	DN1	DN2	a	f	h	h1	h2	n	n1	w	s	1~	3~
NGAm 1B	NGA 1B	1½"	1½"	41	297	227	92	135	190	160	50	10	12.7	11.8
NGAm 1A	NGA 1A												12.8	11.9

ABSORPTION

MODEL	VOLTAGE (single-phase)		
Single-phase	230 V	240 V	110 V
NGAm 1B	5.6 A	5.3 A	11.2 A
NGAm 1A	6.2 A	6.0 A	12.0 A

MODEL	VOLTAGE (three-phase)					
Three-phase	230 V	400 V	690 V	240 V	415 V	720 V
NGA 1B	3.3 A	1.9 A	1.1 A	3.2 A	1.85 A	1.1 A
NGA 1A	3.7 A	2.1 A	1.2 A	3.7 A	2.1 A	1.2 A

PALLETIZATION

MODEL		GROUPAGE				CONTAINER			
Single-phase	Three-phase	n° pumps	H (mm)	kg		n° pumps	H (mm)	kg	
				1~	3~			1~	3~
NGAm 1B	NGA 1B	70	1415	910	840	112	2180	1440	1340
NGAm 1A	NGA 1A	70	1415	920	850	112	2180	1450	1350

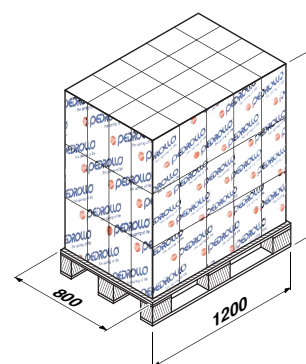

PRO-NGA

Stainless steel pump with open impeller



PERFORMANCE RANGE

- Flow rate up to **350 l/min** (21 m³/h)
- Head up to **20 m**

APPLICATION LIMITS

- Manometric suction lift up to **7 m**
- Liquid temperature between **-10 °C** and **+90 °C**
- Ambient temperature between **-10 °C** and **+40 °C**
- Max. working pressure **6 bar**
- Passage of suspended solids up to **Ø 10 mm**
- Continuous service **S1**

CONSTRUCTION AND SAFETY STANDARDS

EN 60034-1
IEC 60034-1
CEI 2-3



CERTIFICATIONS



INSTALLATION AND USE

Suitable for use with clean water and liquids that are not chemically aggressive towards the materials from which the pump is made. The open impeller design allows **liquids containing relatively high levels of impurities** to be pumped without the risk of the impeller clogging. All of the components in contact with the pumped liquid are constructed in stainless steel AISI 316. As a result of these characteristics the PRO-NGA series pumps find specific use in assemblies for washing fruit, vegetables, fish and shellfish, in industrial assemblies for washing metallic objects and glass containers, as well as for the circulation of cooling liquids. The pump should be installed in an enclosed environment, or at least sheltered from inclement weather.

OPTIONALS AVAILABLE ON REQUEST

- Special mechanical seal
- Other voltages or 60 Hz frequency

GUARANTEE

1 year subject to terms and conditions

CHARACTERISTIC CURVES AND PERFORMANCE DATA

50 Hz n= 2900 1/min HS= 0 m

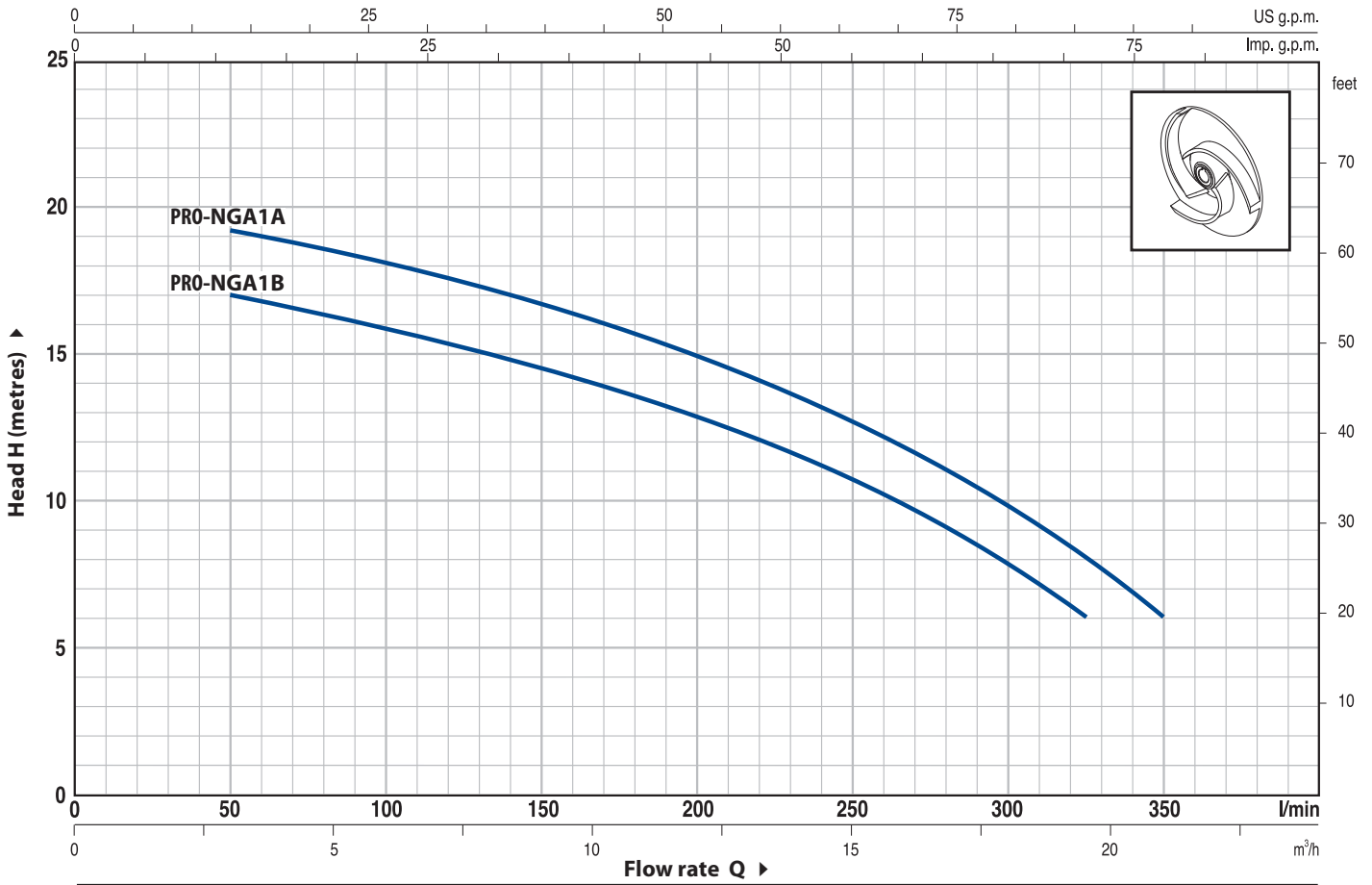

MODEL		POWER		Q	Flow rate											
Single-phase	Three-phase	kW	HP		m ³ /h	0	3	6	9	12	15	18	19.5	21		
PRO-NGAm 1B	PRO-NGA 1B	0.55	0.75	l/min	0	50	100	150	200	250	300	325	350			
				H metres	18	17	16	14.5	13	10.5	8	6				
PRO-NGAm 1A	PRO-NGA 1A	0.75	1		20	19.5	18	16.5	15	12.5	10	8	6			

Q = Flow rate H = Total manometric head HS = Suction height

Tolerance of characteristic curves in compliance with EN ISO 9906 App. A.

POS.	COMPONENT	CONSTRUCTION CHARACTERISTICS				
1	PUMP BODY	Stainless steel AISI 316, complete with threaded ports in compliance with ISO 228/1				
2	BODY BACKPLATE	Stainless steel AISI 316				
3	IMPELLER	Open impeller in stainless steel 316				
4	MOTOR SHAFT	Stainless steel AISI 316				
5	MECHANICAL SEAL	<i>Seal</i>	<i>Shaft</i>	<i>Materials</i>		
		<i>Model</i>	<i>Diameter</i>	<i>Stationary ring</i>	<i>Rotational ring</i>	<i>Elastomer</i>
		AR-14S	Ø 14 mm	Ceramic	Graphite	Viton
6	BEARINGS	6203 ZZ / 6203 ZZ				
7	CAPACITOR	<i>Pump</i>	<i>Capacitance</i>			
		<i>Single-phase</i>	<i>(230 V or 240 V)</i>		<i>(110 V)</i>	
		PRO-NGAm 1B	16 µF 450 VL	60 µF 300 VL		
		PRO-NGAm 1A	20 µF 450 VL	60 µF 300 VL		

- 8 ELECTRIC MOTOR
- PRO-NGAm: single-phase 230 V - 50 Hz with thermal overload protector built-in to the winding.
 PRO-NGA: three-phase 230/400 V - 50 Hz.
- ⇒ Pumps fitted with the three-phase motor option offer IE2 (IEC 60034-30) class high performance
- Insulation: F class.
 - Protection: IP 44.

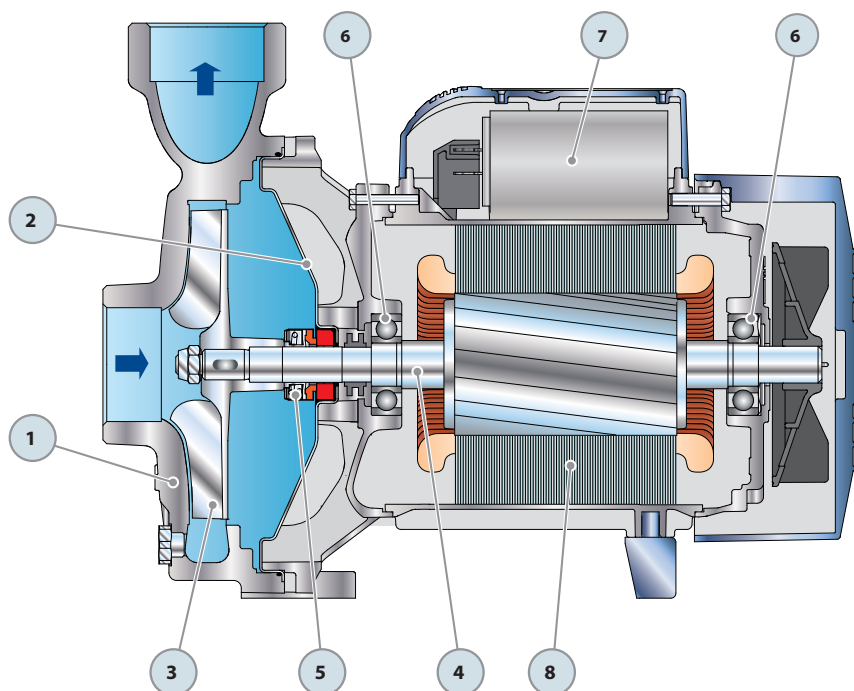

DIMENSIONS AND WEIGHT

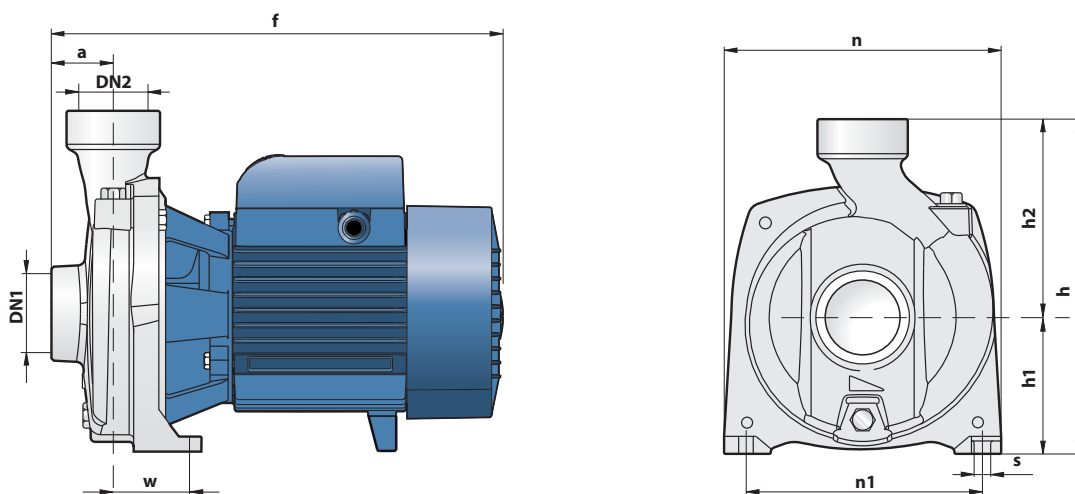

MODEL		PORTS		DIMENSIONS mm									kg	
Single-phase	Three-phase	DN1	DN2	a	f	h	h1	h2	n	n1	w	s	1~	3~
PRO-NGAm 1B	PRO-NGA 1B	1½"	1½"	41	297	227	92	135	190	160	50	10	13.0	11.9
PRO-NGAm 1A	PRO-NGA 1A												13.1	12.0

ABSORPTION

MODEL	VOLTAGE (single-phase)		
	230 V	240 V	110 V
Single-phase	230 V	240 V	110 V
PRO-NGAm 1B	5.6 A	5.3 A	11.2 A
PRO-NGAm 1A	6.2 A	6.0 A	12.0 A

MODEL	VOLTAGE (three-phase)					
	230 V	400 V	690 V	240 V	415 V	720 V
Three-phase	230 V	400 V	690 V	240 V	415 V	720 V
PRO-NGA 1B	3.3 A	1.9 A	1.1 A	3.2 A	1.85 A	1.1 A
PRO-NGA 1A	3.6 A	2.1 A	1.2 A	3.5 A	2.0 A	1.2 A

PALLETIZATION

MODEL		GROUPAGE				CONTAINER			
		n° pumps	H (mm)	kg		n° pumps	H (mm)	kg	
Single-phase	Three-phase			1~	3~			1~	3~
PRO-NGAm 1B	PRO-NGA 1B	70	1415	930	850	112	2180	1480	1350
PRO-NGAm 1A	PRO-NGA 1A	70	1415	940	860	112	2180	1490	1360

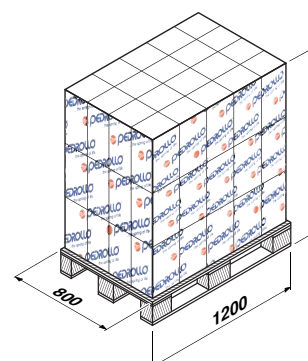



PERFORMANCE RANGE

- Flow rate up to **450 l/min** (27 m³/h)
- Head up to **112 m**

APPLICATION LIMITS

- Manometric suction lift up to **7 m**
- Liquid temperature between **-10 °C** and **+90 °C**
(up to +40 for the version with the technopolymer impeller)
- Ambient temperature between **-10 °C** and **+40 °C**
- Max. working pressure **10 bar**
(**6 bar** for 2CP25/130N)
- Continuous service **S1**

CONSTRUCTION AND SAFETY STANDARDS

EN 60034-1
IEC 60034-1
CEI 2-3



CERTIFICATIONS



INSTALLATION AND USE

Suitable for use with clean water and liquids that are not chemically aggressive towards the materials from which the pump is made. The high efficiency and adaptability of these pumps to even the most unusual of applications, makes them ideal for use in the domestic, civil and industrial sectors; in particular for the distribution of water in combination with pressure sets, for pressure boosting and in fire-fighting sets.

The pump should be installed in an enclosed environment, or at least sheltered from inclement weather.

OPTIONALS AVAILABLE ON REQUEST

- Pumps with technopolymer impeller
- Special mechanical seal
- Other voltages or 60 Hz frequency
- IP55 class protection for:
 - 2CP32/200, – 2CP40/180,
 - 2CP32/210, – 2CP40/200

GUARANTEE

1 year subject to terms and conditions

PERFORMANCE RANGE

50 Hz n= 2900 1/min HS= 0 m

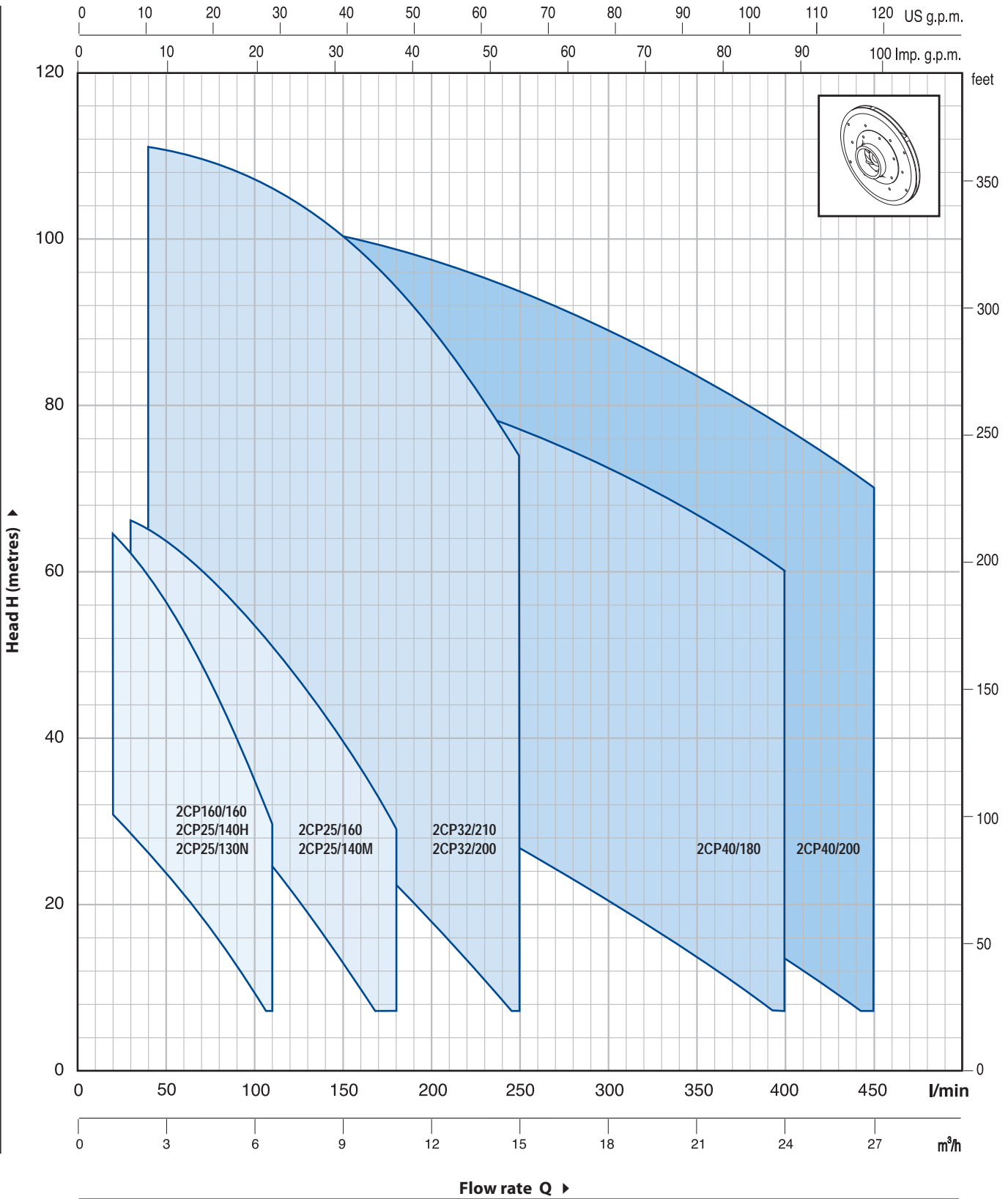

CHARACTERISTIC CURVES AND PERFORMANCE DATA

50 Hz n= 2900 1/min HS= 0 m

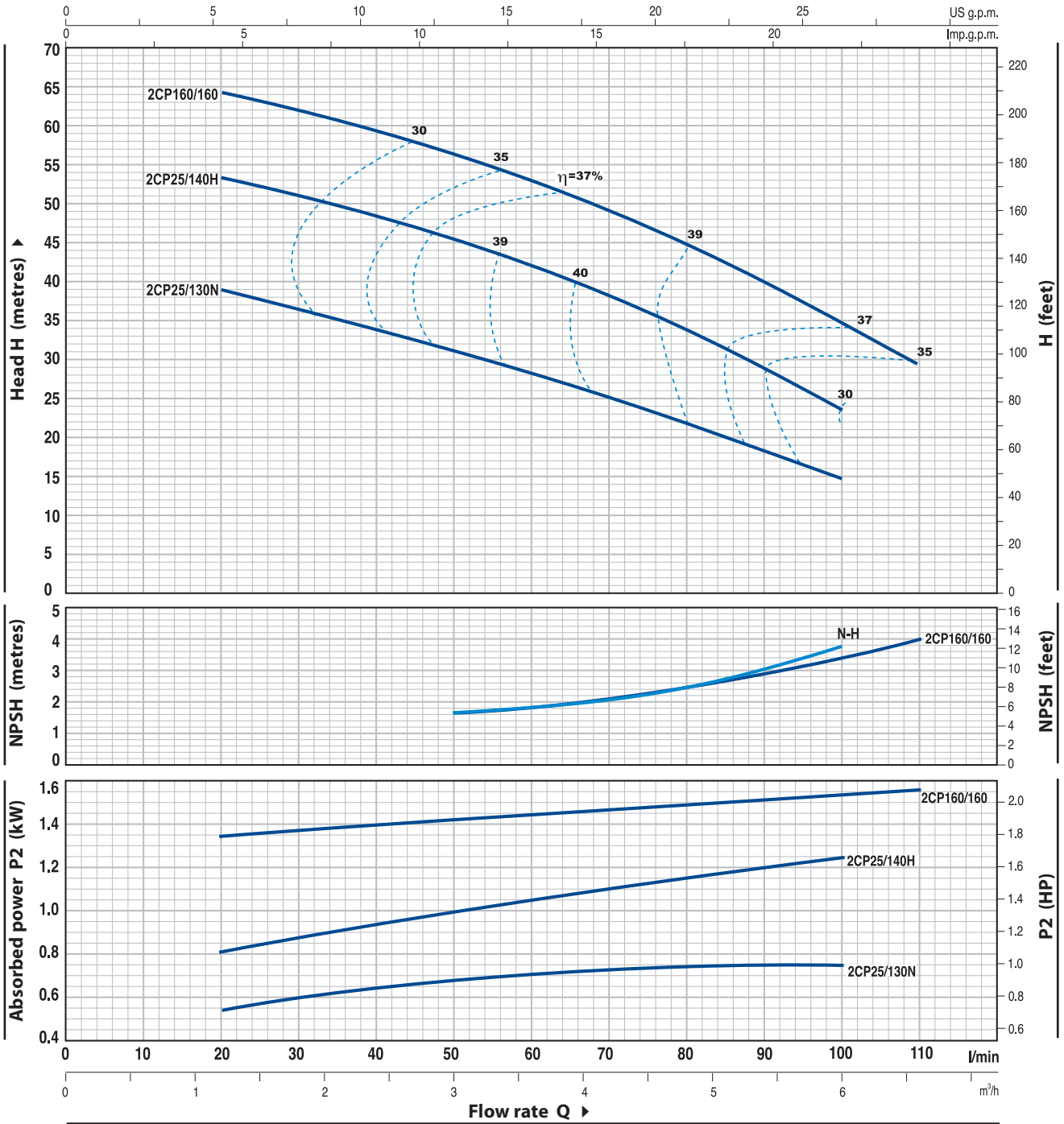

MODEL		POWER		Q	Flow rate												
Single-phase	Three-phase	kW	HP		m³/h	0	1.2	1.8	2.4	3.0	3.6	4.2	4.8	5.4	6.0	6.6	
2CPm 25/130N	2CP 25/130N	0.75	1	l/min	0	20	30	40	50	60	70	80	90	100	110		
				H metres	42	39	37	34	31	28.5	25.5	22	18	15			
					54	53	51	49	46	42	38	34	29	24			
					66	64	62	60	57	53	49	44	39.5	35	30		

Q = Flow rate H = Total manometric head HS = Suction height

Tolerance of characteristic curves in compliance with EN ISO 9906 App. A.

CHARACTERISTIC CURVES AND PERFORMANCE DATA

50 Hz n= 2900 1/min HS= 0 m

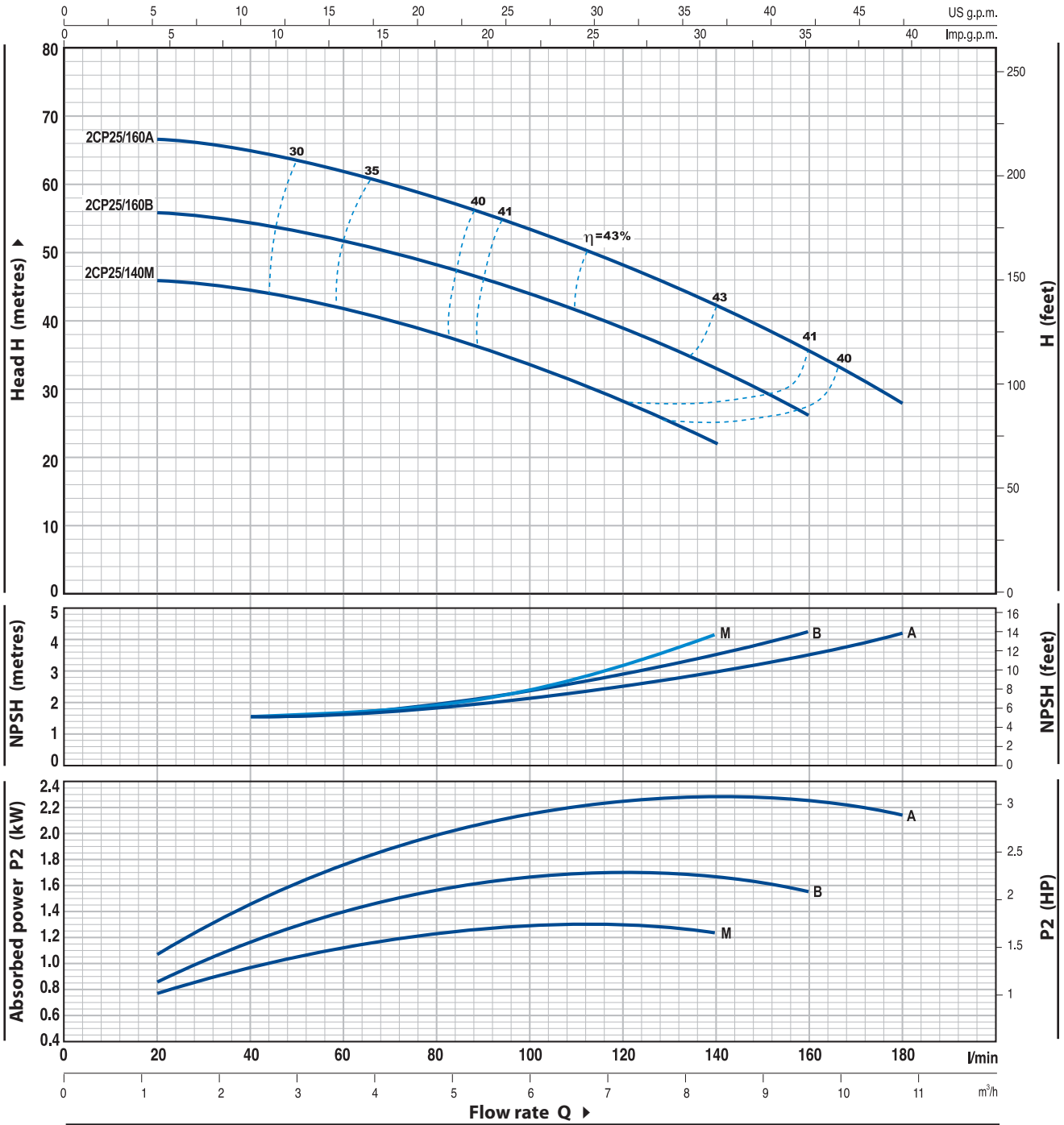

MODEL		POWER		Q	Flow rate																	
Single-phase	Three-phase	kW	HP		m³/h	0	1.2	1.8	2.4	3.0	3.6	4.2	4.8	5.4	6.0	6.6	7.5	8.4	9.6	10.8		
				l/min	0	20	30	40	50	60	70	80	90	100	110	125	140	160	180			
2CPm 25/140M	2CP 25/140M	1.1	1.5	H metres	47	46	45.5	44	43	42	41	38	36	34	31	27	22					
2CPm 25/160B	2CP 25/160B	1.5	2		58	56	55	54	53	52	50	48	46	44	41	37	33	26				
-	2CP 25/160A	2.2	3		68	66.5	65.5	65	63	62	60	58	56	54	51	47	42	35	28			

Q = Flow rate H = Total manometric head HS = Suction height

Tolerance of characteristic curves in compliance with EN ISO 9906 App. A.

CHARACTERISTIC CURVES AND PERFORMANCE DATA

50 Hz n= 2900 1/min HS= 0 m

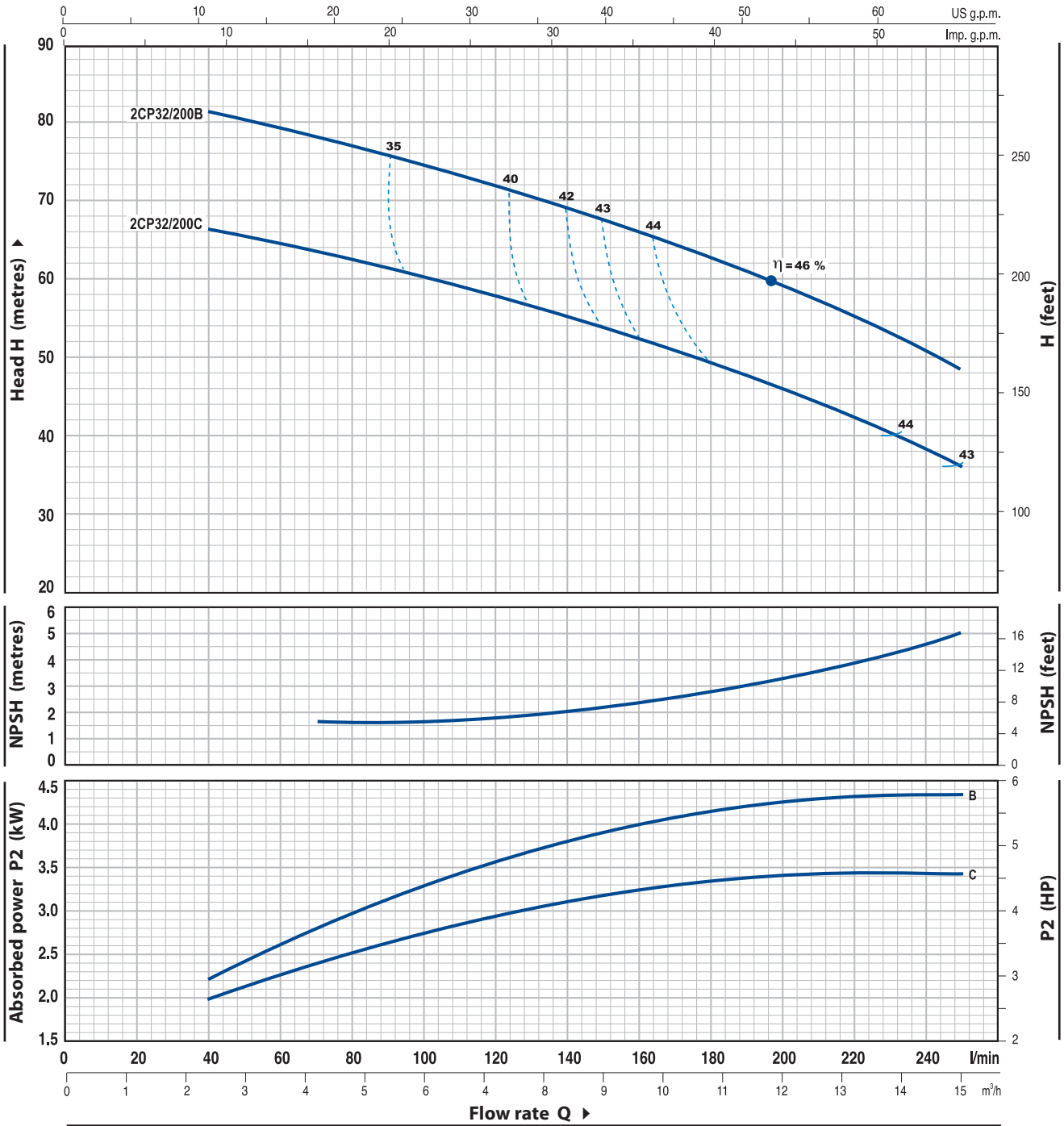

MODEL	POWER		Q	0	2.4	3.0	3.6	4.2	4.8	5.4	6.0	6.6	7.5	8.4	9.6	10.8	12.0	15.0
	kW	HP		0	40	50	60	70	80	90	100	110	125	140	160	180	200	250
Three-phase			H metres	70	66.5	65.5	65	64	63	62	60.5	59	57	55	52	49.5	46.5	36
2CP 32/200C	3	4		85	81	80	79	78	77	76	75	74	72	69	66	62	58	49
2CP 32/200B	4	5.5																

Q = Flow rate H = Total manometric head HS = Suction height

Tolerance of characteristic curves in compliance with EN ISO 9906 App. A.

CHARACTERISTIC CURVES AND PERFORMANCE DATA

50 Hz n= 2900 1/min HS= 0 m

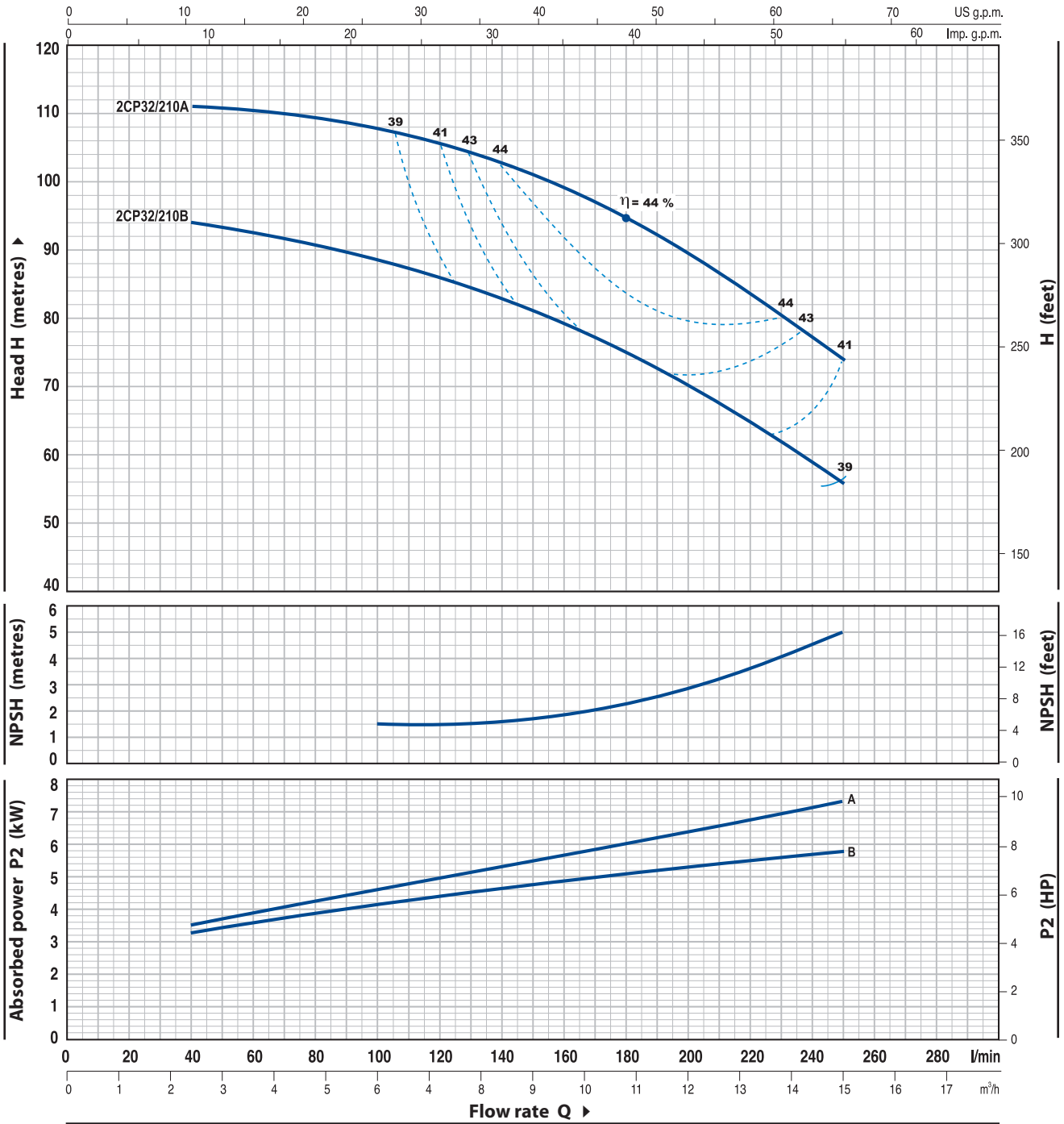

MODEL	POWER		Q	Flow rate																
	kW	HP		m ³ /h	0	2.4	3.0	3.6	4.2	4.8	5.4	6.0	6.6	7.5	8.4	9.6	10.8	12.0	15.0	
Three-phase			l/min	0	40	50	60	70	80	90	100	110	125	140	160	180	200	250		
2CP 32/210B	5.5	7.5	H metres	94	94	93.5	93	92	91	90	89	87	85	83	79	75	70	56		
2CP 32/210A	7.5	10		112	111	110.8	110.5	110.3	110	109	108	107	105	102	99	94	89	74		

Q = Flow rate H = Total manometric head HS = Suction height

Tolerance of characteristic curves in compliance with EN ISO 9906 App. A.

CHARACTERISTIC CURVES AND PERFORMANCE DATA

50 Hz n= 2900 1/min HS= 0 m

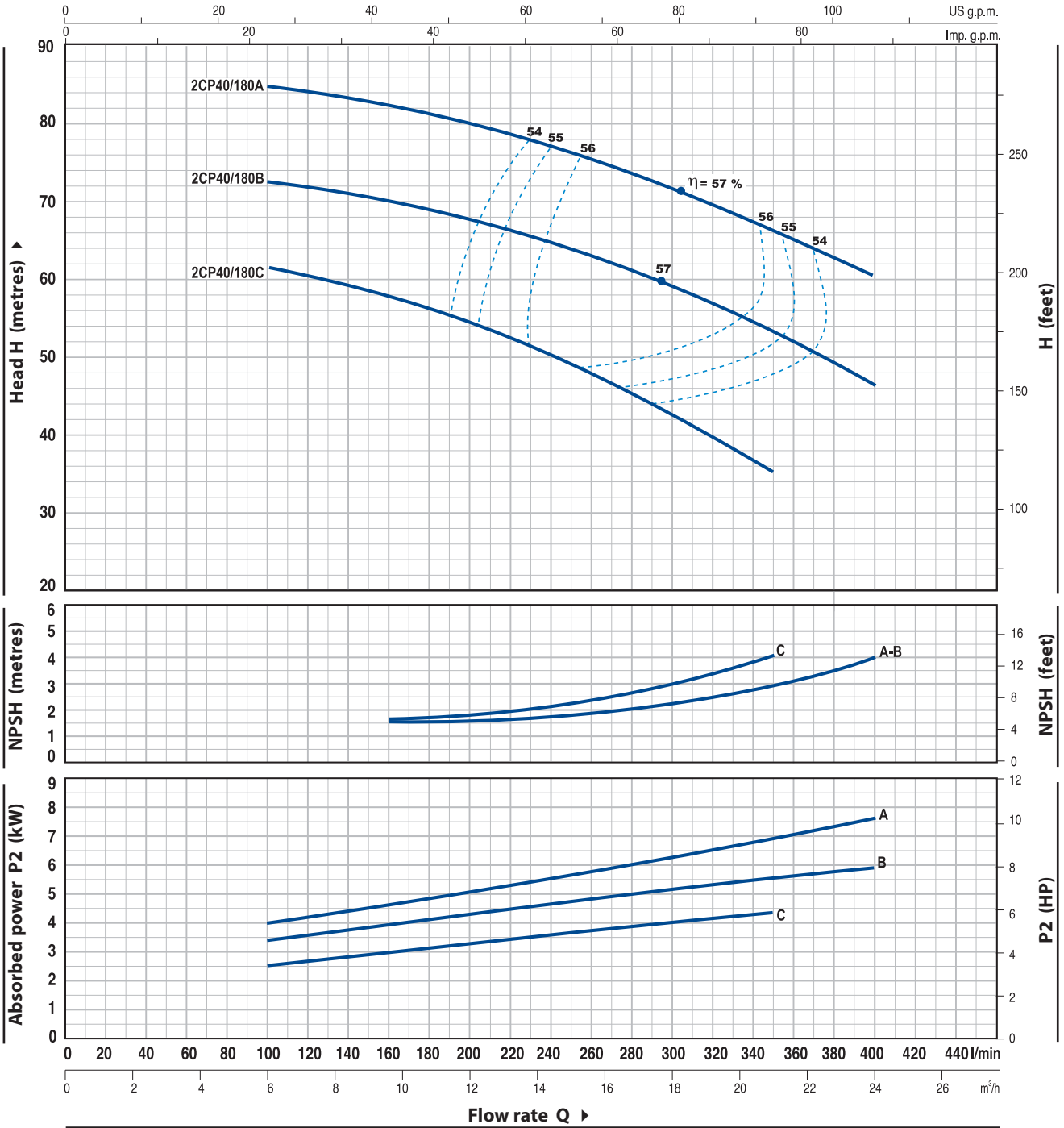

MODEL	POWER		Q	0	6.0	6.6	7.5	8.4	9.6	10.8	12.0	15.0	18.0	21.0	24.0
	kW	HP		0	100	110	125	140	160	180	200	250	300	350	400
Three-phase			l/min												
2CP 40/180C	4	5.5	H metres	64	62	61	60	59	58	56	54.5	49	43	35	
2CP 40/180B	5.5	7.5		76	73	72.5	72	71	70	69	67.5	64	59.5	54	46
2CP 40/180A	7.5	10		88	85	84.5	84	83	82	81	79.5	76	72	67	60

Q = Flow rate H = Total manometric head HS = Suction height

Tolerance of characteristic curves in compliance with EN ISO 9906 App. A.

CHARACTERISTIC CURVES AND PERFORMANCE DATA

50 Hz n= 2900 1/min HS= 0 m

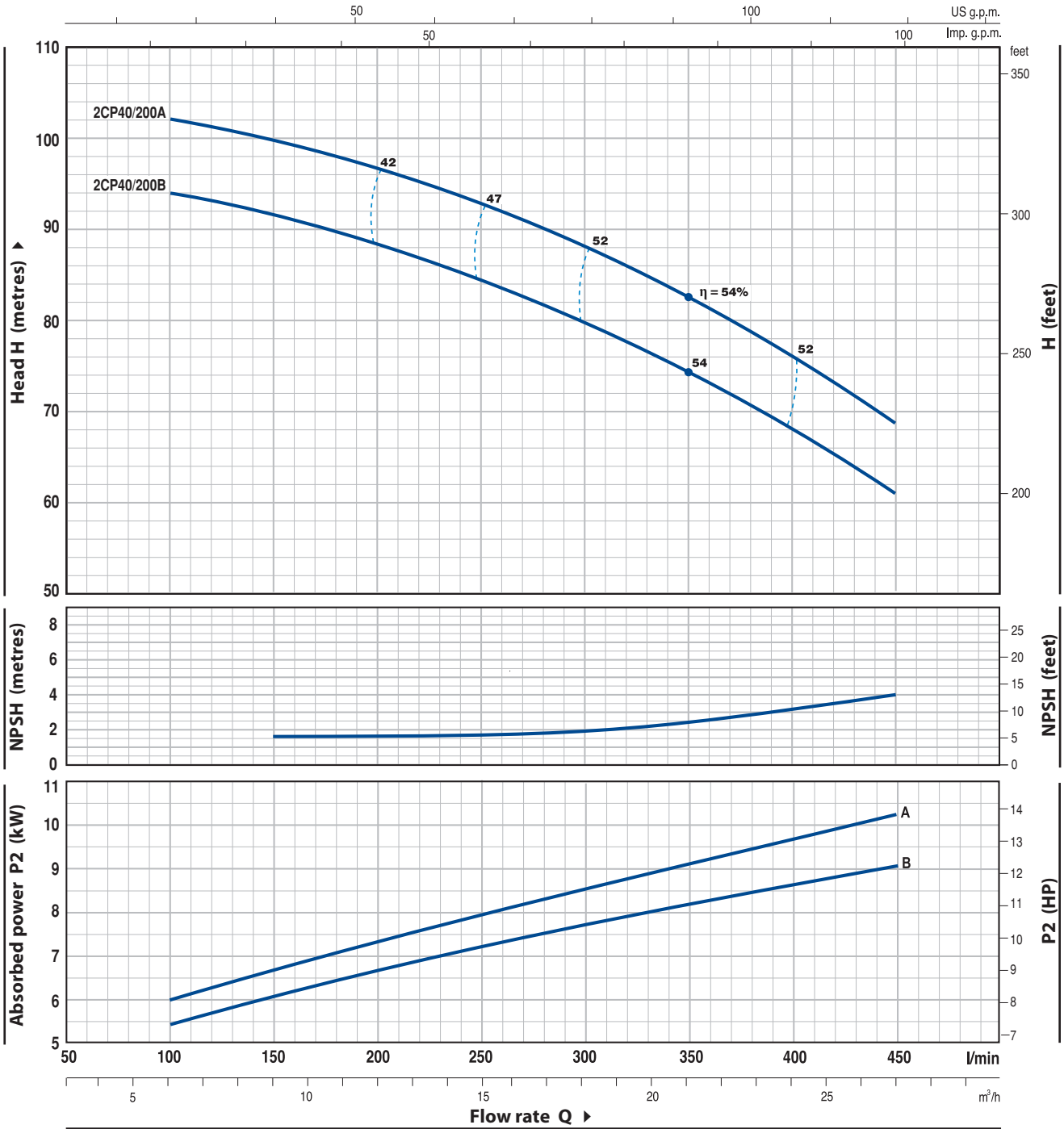

MODEL	POWER		Q	0	6.0	9	10.8	12.0	15.0	18.0	21.0	24.0	27.0
	kW	HP		0	100	150	180	200	250	300	350	400	450
Three-phase			H metres	97	94	92	90	88	85	80	74	68	61
2CP 40/200B	9.2	12.5		105	102	100	98	97	93	88	83	76	69
2CP 40/200A	11	15											

Q = Flow rate H = Total manometric head HS = Suction height

Tolerance of characteristic curves in compliance with EN ISO 9906 App. A.

2CP 25/130N

POS.	COMPONENT	CONSTRUCTION CHARACTERISTICS				
1	PUMP BODY	Cast iron, complete with threaded ports in compliance with ISO 228/1				
2	BODY BACKPLATE	Stainless steel AISI 304				
3	IMPELLERS	Stainless steel AISI 304				
4	MOTOR SHAFT	Stainless steel EN 10088-3 - 1.4104				
5	MECHANICAL SEAL	<i>Seal</i>	<i>Shaft</i>	<i>Materials</i>		
		<i>Model</i>	<i>Diameter</i>	<i>Stationary ring</i>	<i>Rotational ring</i>	<i>Elastomer</i>
		AR-14	Ø 14 mm	Ceramic	Graphite	NBR
6	BEARINGS	6203 ZZ / 6203 ZZ				
7	CAPACITOR	<i>Pump</i>	<i>Capacitance</i>			
		<i>Single-phase</i>	<i>(230 V or 240 V)</i>		<i>(110 V)</i>	
		2CPm 25/130N	20 µF 450 VL		60 µF 300 VL	
8	ELECTRIC MOTOR	2CPm 25/130N: single-phase 230 V - 50 Hz with thermal overload protector built-in to the winding. 2CP 25/130N: three-phase 230/400 V - 50 Hz. ⇒ Pump fitted with the three-phase motor option offers IE2 (IEC 60034-30) class high performance – Insulation: F class. – Protection: IP 44.				

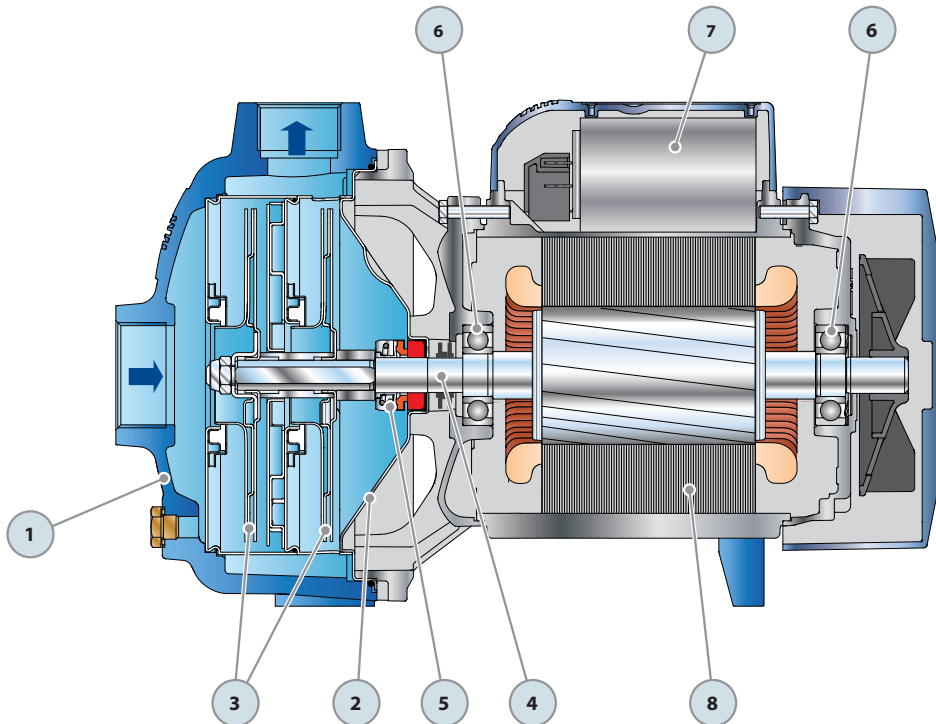

DIMENSIONS AND WEIGHT

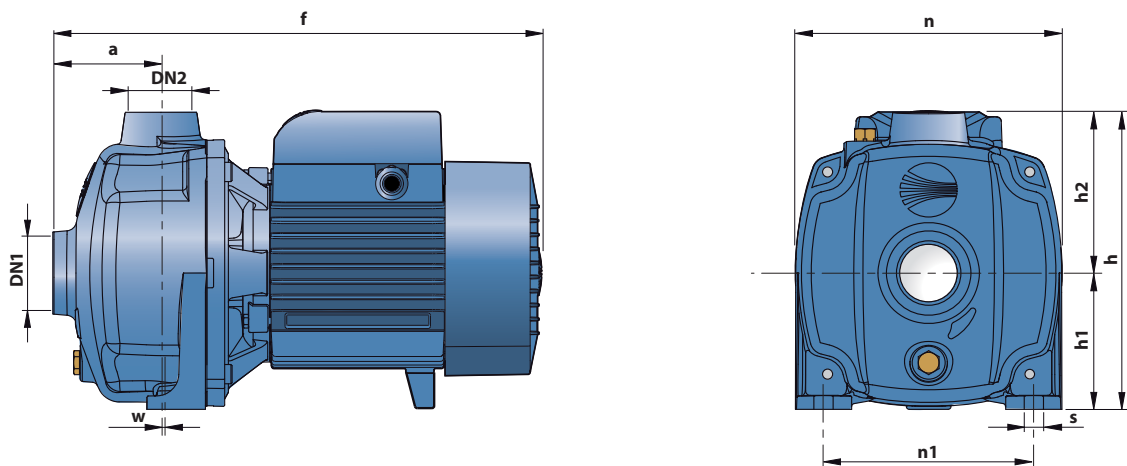

MODEL		PORTS		DIMENSIONS mm									kg	
Single-phase	Three-phase	DN1	DN2	a	f	h	h1	h2	n	n1	w	s	1~	3~
2CPm 25/130N	2CP 25/130N	1 1/4"	1"	73	330	201	92	109	180	142	1	10	14.5	14.0

ABSORPTION

MODEL	VOLTAGE (single-phase)		
	230 V	240 V	110 V
Single-phase	230 V	240 V	110 V
2CPm 25/130N	6.3 A	6.0 A	12.6 A

MODEL	VOLTAGE (three-phase)					
	230 V	400 V	690 V	240 V	415 V	720 V
Three-phase	230 V	400 V	690 V	240 V	415 V	720 V
2CP 25/130N	4.6 A	2.6 A	1.5 A	4.3 A	2.5 A	1.5 A

PALLETIZATION

MODEL		GROUPAGE				CONTAINER			
Single-phase	Three-phase	n° pumps	H (mm)	kg		n° pumps	H (mm)	kg	
				1~	3~			1~	3~
2CPm 25/130N	2CP 25/130N	60	1320	890	860	84	1790	1240	1200

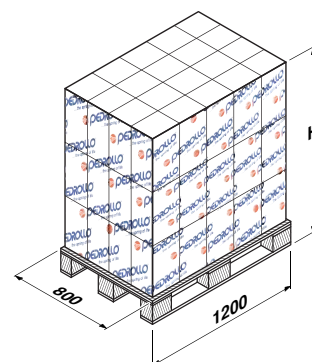

POS.	COMPONENT	CONSTRUCTION CHARACTERISTICS					
1	PUMP BODY	Cast iron, complete with threaded ports in compliance with ISO 228/1					
2	IMPELLERS	Brass					
3	MOTOR SHAFT	Stainless steel EN 10088-3 - 1.4104					
4	MECHANICAL SEAL	<i>Pump Model</i>	<i>Seal Model</i>	<i>Shaft Diameter</i>	<i>Stationary ring</i>	<i>Rotational ring</i>	<i>Elastomer</i>
		2CP 25/140	FN-18	Ø 18 mm	Graphite	Ceramic	NBR
		2CP 25/160					
		2CP 160/160					
		2CP 32/200	FN-20	Ø 20 mm	Graphite	Ceramic	NBR
		2CP 32/210	FN-24	Ø 24 mm	Graphite	Ceramic	NBR
		2CP 40/180					
		2CP 40/200	FN-32 NU	Ø 32 mm	Graphite	Ceramic	NBR
5	BEARINGS	<i>Pump Model</i>	<i>Model</i>				
		2CP 25/140	6204 ZZ / 6204 ZZ				
		2CP 25/160					
		2CP 160/160					
		2CP 32/200	6206 ZZ - C3 / 6206 ZZ - C3				
		2CP 32/210	6306 ZZ - C3 / 6206 ZZ - C3				
		2CP 40/180					
		2CP 40/200	6308 ZZ - C3 / 6308 ZZ - C3				
6	CAPACITOR	<i>Pump</i>	<i>Capacitance</i>				
		<i>Single-phase</i>	<i>(230 V or 240 V)</i>	<i>(110 V)</i>			
		2CPm 25/140	25 µF 450 VL	60 µF 250 VL			
		2CPm 160/160	45 µF 450 VL	80 µF 250 VL			
		2CPm 25/160B	45 µF 450 VL	80 µF 250 VL			
7	ELECTRIC MOTOR	2CPm: single-phase 230 V - 50 Hz with thermal overload protector built-in to the winding.					
		2CP: three-phase 230/400 V - 50 Hz up to 4 kW.					
		400/690 V - 50 Hz from 5.5 to 11 kW					
<p>⇒ Pumps fitted with the three-phase motor option offer IE2 (IEC 60034-30) class high performance</p> <ul style="list-style-type: none"> - Insulation: F class. - Protection: IP 44. 							

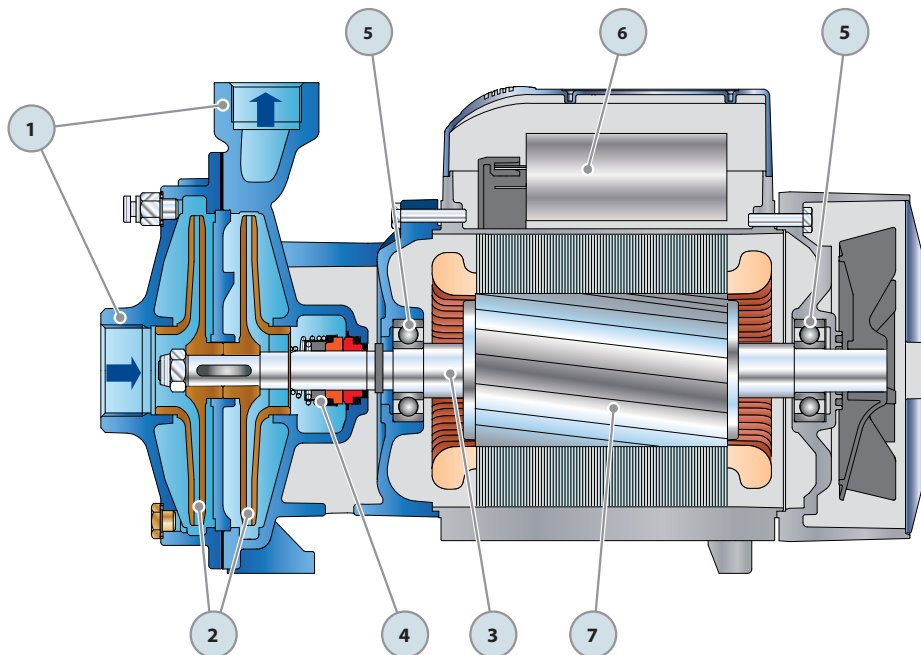

DIMENSIONS AND WEIGHT

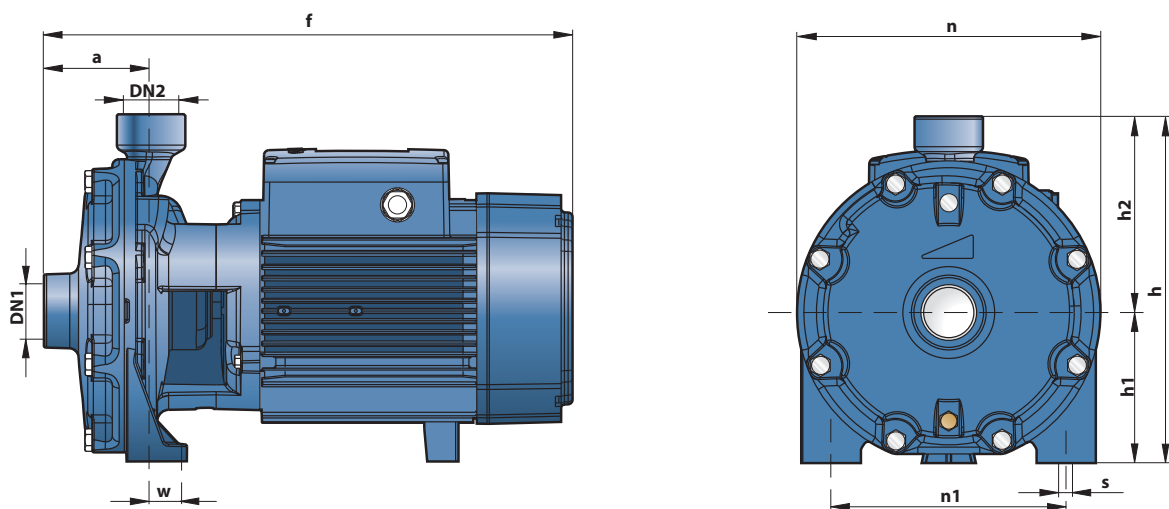

MODEL		PORTS		DIMENSIONS mm									kg	
Single-phase	Three-phase	DN1	DN2	a	f	h	h1	h2	n	n1	w	s	1~	3~
2CPm 25/140H	2CP 25/140H	1 1/4"	1"	74	382	225	93	132	200	162	23	10	18.9	18.3
2CPm 160/160	2CP 160/160			84	405	263	110	153	225	185	26	11	24.5	23.3
2CPm 25/140M	2CP 25/140M			74	382	225	93	132	200	162	23	10	18.9	18.3
2CPm 25/160B	2CP 25/160B-A	1 1/2"	1 1/4"	86	407	263	110	153	225	185	26	11	24.3	23.2/ 24.5
-	2CP 32/200C-B			95	464	304	132	172	266	206	19	-	38.0/43.0	
-	2CP 32/210B-A	2"	1 1/2"		542								-	54.0/61.0
-	2CP 40/180C			108	496	334	139	195	292	232	21	14	-	49.0
-	2CP 40/180B-A				542									-
-	2CP 40/200B-A			110	566	355	160	195	298				-	89.0/90.0

ABSORPTION

MODEL	VOLTAGE (single-phase)		
	230 V	240 V	110 V
Single-phase	230 V	240 V	110 V
2CPm 25/140H	7.6 A	7.0 A	15.2 A
2CPm 160/160	11.0 A	10.0 A	21.0 A
2CPm 25/140M	8.0 A	7.3 A	16.0 A
2CPm 25/160B	11.0 A	10.0 A	21.0 A

MODEL	VOLTAGE (three-phase)					
	230 V	400 V	690 V	240 V	415 V	720 V
Three-phase	230 V	400 V	690 V	240 V	415 V	720 V
2CP 25/140H	5.7 A	3.3 A	1.9 A	5.2 A	3.0 A	1.7 A
2CP 160/160	8.0 A	4.6 A	2.7 A	7.0 A	4.0 A	2.3 A
2CP 25/140M	5.9 A	3.4 A	2.0 A	5.4 A	3.1 A	1.8 A
2CP 25/160B	8.0 A	4.6 A	2.7 A	7.7 A	4.4 A	2.6 A
2CP 25/160A	9.3 A	5.4 A	3.1 A	8.7 A	5.0 A	2.9 A
2CP 32/200C	12.8 A	7.4 A	4.3 A	12.3 A	7.1 A	4.1 A
2CP 32/200B	18.2 A	10.5 A	6.1 A	17.7 A	10.2 A	5.9 A
2CP 32/210B	21.7 A	12.5 A	7.2 A	19.9 A	11.5 A	6.7 A
2CP 32/210A	27.7 A	16.0 A	9.2 A	26.0 A	15.0 A	8.7 A
2CP 40/180C	17.0 A	9.8 A	5.7 A	16.5 A	9.5 A	5.5 A
2CP 40/180B	21.3 A	12.3 A	7.1 A	20.8 A	12.0 A	6.9 A
2CP 40/180A	26.7 A	15.4 A	8.9 A	26.0 A	15.0 A	8.7 A
2CP 40/200B	-	17.5 A	10.1 A	-	17.5 A	10.1 A
2CP 40/200A	-	20.0 A	11.5 A	-	20.0 A	11.5 A

PALLETIZATION

MODEL		GROUPAGE			CONTAINER				
Single-phase	Three-phase	n° pumps	H (mm)	kg		n° pumps	H (mm)	kg	
				1~	3~			1~	3~
2CPm 25/140H	2CP 25/140H	50	1370	960	930	70	1860	1340	1300
2CPm 160/160	2CP 160/160	50	1540	1240	1180	70	2100	1730	1650
2CPm 25/140M	2CP 25/140M	50	1370	960	930	70	2860	1340	1300
2CPm 25/160B	2CP 25/160B	50	1540	1230	1180	70	2100	1720	1640
-	2CP 25/160A	50	1540	-	1240	70	2100	-	1730
-	2CP 32/200C	18	1420	-	700	24	1840	-	930
-	2CP 32/200B	18	1420	-	790	24	1840	-	1050
-	2CP 32/210B	12	1420	-	670	16	1840	-	880
-	2CP 32/210A	12	1420	-	750	16	1840	-	1000
-	2CP 40/180C	12	1420	-	610	16	1840	-	800
-	2CP 40/180B	12	1420	-	670	16	1840	-	880
-	2CP 40/180A	12	1420	-	740	16	1840	-	980
-	2CP 40/200B	6	1200	-	551	9	1730	-	818
-	2CP 40/200A	6	1200	-	557	9	1730	-	827

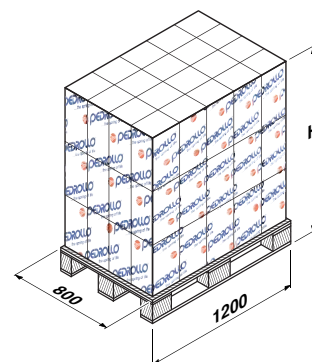

2÷4CP

Multi-stage centrifugal pumps



PERFORMANCE RANGE

- Flow rate up to **130 l/min** (7.8 m³/h)
- Head up to **50 m**

APPLICATION LIMITS

- Manometric suction lift up to **7 m**
- Liquid temperature between **-10 °C** and **+40 °C**
- Ambient temperature up to **+40 °C**
- Max. working pressure **6 bar**
- Continuous service **S1**

SAFETY STANDARDS

EN 60335-1
IEC 60335-1
CEI 61-150

EN 60034-1
IEC 60034-1
CEI 2-3



CERTIFICATIONS



INSTALLATION AND USE

Suitable for use with clean water and liquids that are not chemically aggressive towards the materials from which the pump is made. As a result of their quietness, these pumps are widely used in domestic applications such as the distribution of water in combination with small and medium sized pressure sets, and for the irrigation of gardens and allotments, etc. The pump should be installed in an enclosed environment, or at least sheltered from inclement weather.

PATENTS - TRADE MARKS - MODELS

- Registered Community Design n° 342159-0006

OPTIONALS AVAILABLE ON REQUEST

- Other voltages or 60 Hz frequency

GUARANTEE

1 year subject to terms and conditions

CHARACTERISTIC CURVES AND PERFORMANCE DATA

50 Hz n= 2900 1/min HS= 0 m

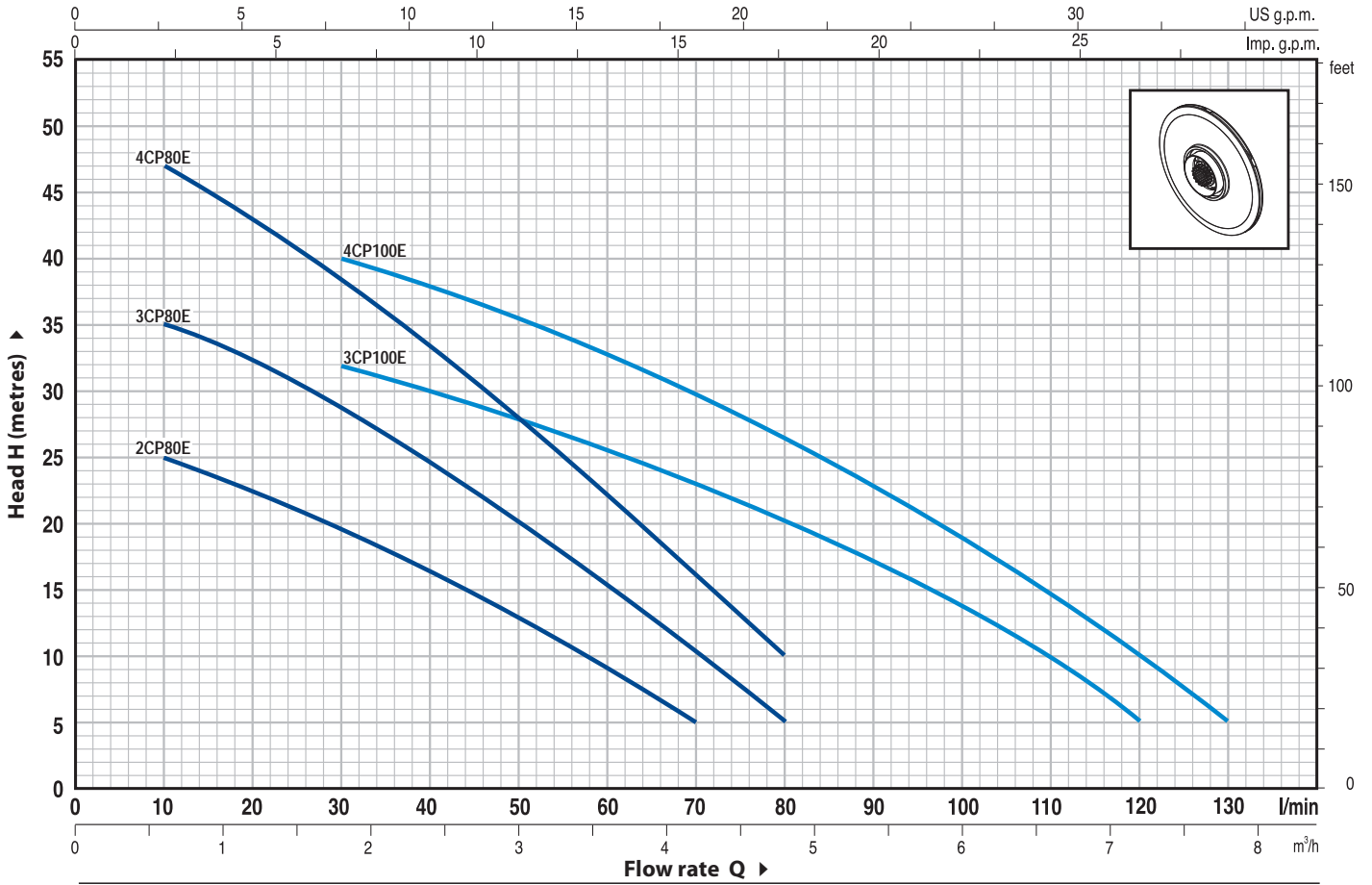

MODEL		POWER		Q	m ³ /h																		
Single-phase	Three-phase	kW	HP		0	0.3	0.6	0.9	1.2	1.5	1.8	2.4	3.0	3.6	4.2	4.8	5.4	6.0	6.6	7.2	7.8		
				l/min	0	5	10	15	20	25	30	40	50	60	70	80	90	100	110	120	130		
2CPm 80E	-	0.37	0.50	H metres	27	26	25	24	22.5	21	20	16.5	13	9	5								
3CPm 80E	3CP 80E	0.45	0.60		38	36	35	34	33.5	31	29	25	20	15.5	10	5							
4CPm 80E	4CP 80E	0.60	0.85		50	48	47	45	43	40.5	38.5	33.5	28	22.5	16	10							
3CPm 100E	3CP 100E	0.60	0.85		36	35.5	35	34	33.5	32.5	32	30	28	26	23	20	17	13.5	10	5			
4CPm 100E	4CP 100E	0.75	1		46	45	44	43	42	41	40	38	35.5	33	30	26.5	22.5	19	15	10	5		

Q = Flow rate H = Total manometric head HS = Suction height

Tolerance of characteristic curves in compliance with EN ISO 9906 App. A.

POS.	COMPONENT	CONSTRUCTION CHARACTERISTICS				
1	PUMP BODY	Cast iron, complete with threaded ports in compliance with ISO 228/1				
2	BODY BACKPLATE	Stainless steel AISI 304				
3	IMPELLERS	Noryl GFN2V				
4	MOTOR SHAFT	Stainless steel EN 10088-3 - 1.4104				
5	MECHANICAL SEAL	<i>Seal</i>	<i>Shaft</i>	<i>Materials</i>		
		<i>Model</i>	<i>Diameter</i>	<i>Stationary ring</i>	<i>Rotational ring</i>	<i>Elastomer</i>
		AR-13	Ø 13 mm	Ceramic	Graphite	NBR
6	BEARINGS	<i>Pump</i>	<i>Model</i>			
		2CPm 80E	6202 ZZ - C3 / 6201 ZZ			
		3CPm 80E				
		4CPm 80E				
		3CP 100E	6203 ZZ / 6203 ZZ			
4CP 100E						
7	CAPACITOR	<i>Pump</i>	<i>Capacitance</i>			
		<i>Single-phase</i>	<i>(230 V or 240 V)</i>	<i>(110 V)</i>		
		2CPm 80E	10 µF 450 VL	25 µF 250 VL		
		3CPm 80E	12.5 µF 450 VL	30 µF 250 VL		
		4CPm 80E	14 µF 450 VL	30 µF 250 VL		
		3CPm 100E	20 µF 450 VL	60 µF 300 VL		
8	ELECTRIC MOTOR	2-3-4CPm: single-phase 230 V - 50 Hz with thermal overload protector built-in to the winding.				
		2-3-4CP: three-phase 230/400 V - 50 Hz.				
		<p>➔ Pumps fitted with the three-phase motor option offer IE2 (IEC 60034-30) class high performance</p> <ul style="list-style-type: none"> - Insulation: F class. - Protection: IP 44. 				

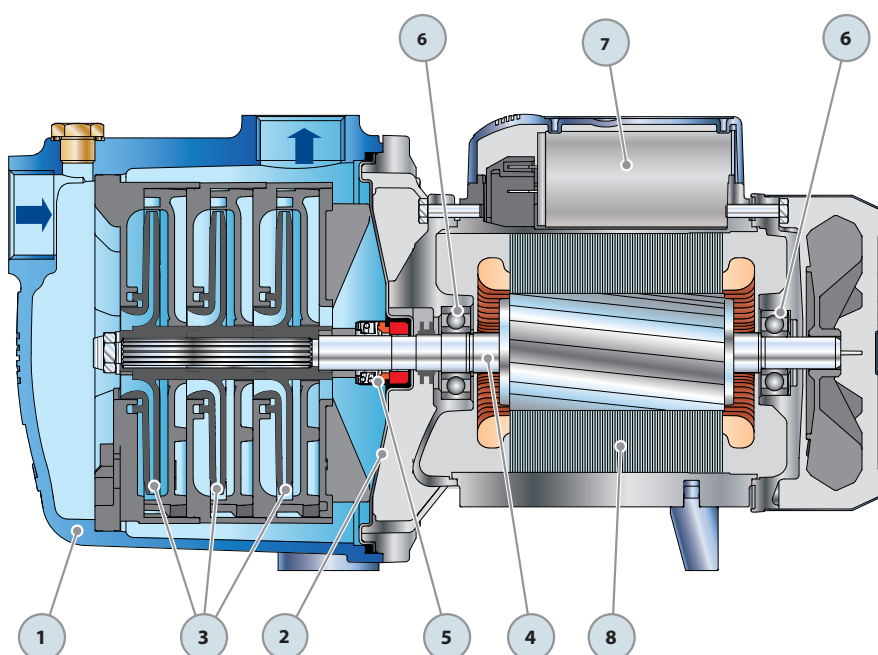

DIMENSIONS AND WEIGHT

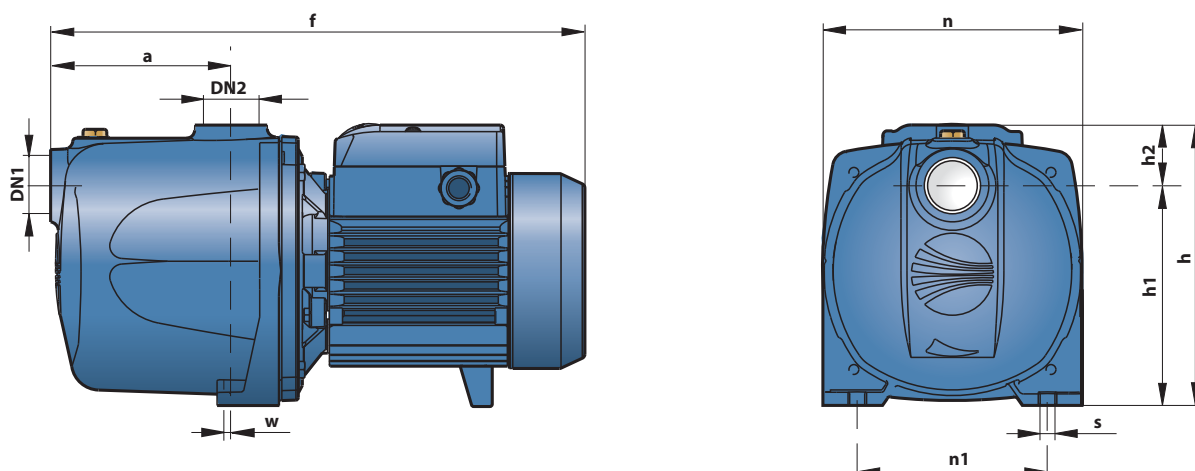

MODEL		PORTS		DIMENSIONS mm									kg	
Single-phase	Three-phase	DN1	DN2	a	f	h	h1	h2	n	n1	w	s	1~	3~
2CPm 80E	–	1"	1"	110	334	172	134	38	158	116	2	9	9.0	–
3CPm 80E	3CP 80E			135	357								9.8	9.3
4CPm 80E	4CP 80E			110	334	11.0	10.4							
3CPm 100E	3CP 100E			135	378	191	61	10.4					9.9	
4CPm 100E	4CP 100E			13.7	12.7									

ABSORPTION

MODEL	VOLTAGE (single-phase)		
	230 V	240 V	110 V
Single-phase	230 V	240 V	110 V
2CPm 80E	2.4 A	2.4 A	4.8 A
3CPm 80E	3.4 A	3.3 A	6.8 A
4CPm 80E	4.3 A	4.2 A	8.6 A
3CPm 100E	4.1 A	4.0 A	8.2 A
4CPm 100E	6.0 A	5.8 A	12.0 A

MODEL	VOLTAGE (three-phase)					
	230 V	400 V	690 V	240 V	415 V	720 V
Three-phase	230 V	400 V	690 V	240 V	415 V	720 V
3CP 80E	2.5 A	1.4 A	0.8 A	2.4 A	1.4 A	0.8 A
4CP 80E	3.4 A	2.0 A	1.1 A	3.3 A	1.9 A	1.1 A
3CP 100E	3.1 A	1.8 A	1.0 A	3.0 A	1.7 A	1.0 A
4CP 100E	4.5 A	2.6 A	1.5 A	4.3 A	2.5 A	1.4 A

PALLETIZATION

MODEL		GROUPAGE				CONTAINER			
Single-phase	Three-phase	n° pumps	H (mm)	kg		n° pumps	H (mm)	kg	
				1~	3~			1~	3~
2CPm 80E	–	98	1440	900	–	154	2180	1400	–
3CPm 80E	3CP 80E	98	1440	980	930	154	2180	1530	1450
4CPm 80E	4CP 80E	98	1440	1100	1040	154	2180	1710	1620
3CPm 100E	3CP 100E	98	1440	1040	990	154	2180	1620	1540
4CPm 100E	4CP 100E	98	1540	1360	1260	140	2140	1940	1800

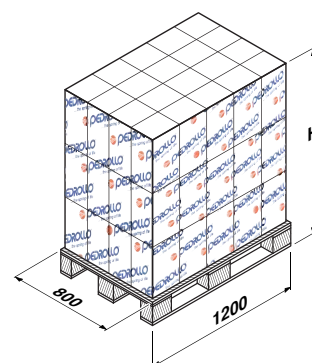

2÷4CR

Multi-stage centrifugal pumps



PERFORMANCE RANGE

- Flow rate up to **120 l/min** (7.2 m³/h)
- Head up to **50 m**

APPLICATION LIMITS

- Manometric suction lift up to **7 m**
- Liquid temperature between **-10 °C** and **+40 °C**
- Ambient temperature up to **+40 °C**
- Max. working pressure **6 bar**
- Continuous service **S1**

SAFETY STANDARDS

EN 60335-1
IEC 60335-1
CEI 61-150

EN 60034-1
IEC 60034-1
CEI 2-3



CERTIFICATIONS



INSTALLATION AND USE

Suitable for use with clean water and liquids that are not chemically aggressive towards the materials from which the pump is made. As a result of their quietness, these pumps are widely used in domestic applications such as the distribution of water in combination with small and medium sized pressure sets, and for the irrigation of gardens and allotments, etc. The pump should be installed in an enclosed environment, or at least sheltered from inclement weather.

OPTIONALS AVAILABLE ON REQUEST

- Special mechanical seal
- Other voltages or 60 Hz frequency

GUARANTEE

1 year subject to terms and conditions

CHARACTERISTIC CURVES AND PERFORMANCE DATA

50 Hz n= 2900 1/min HS= 0 m

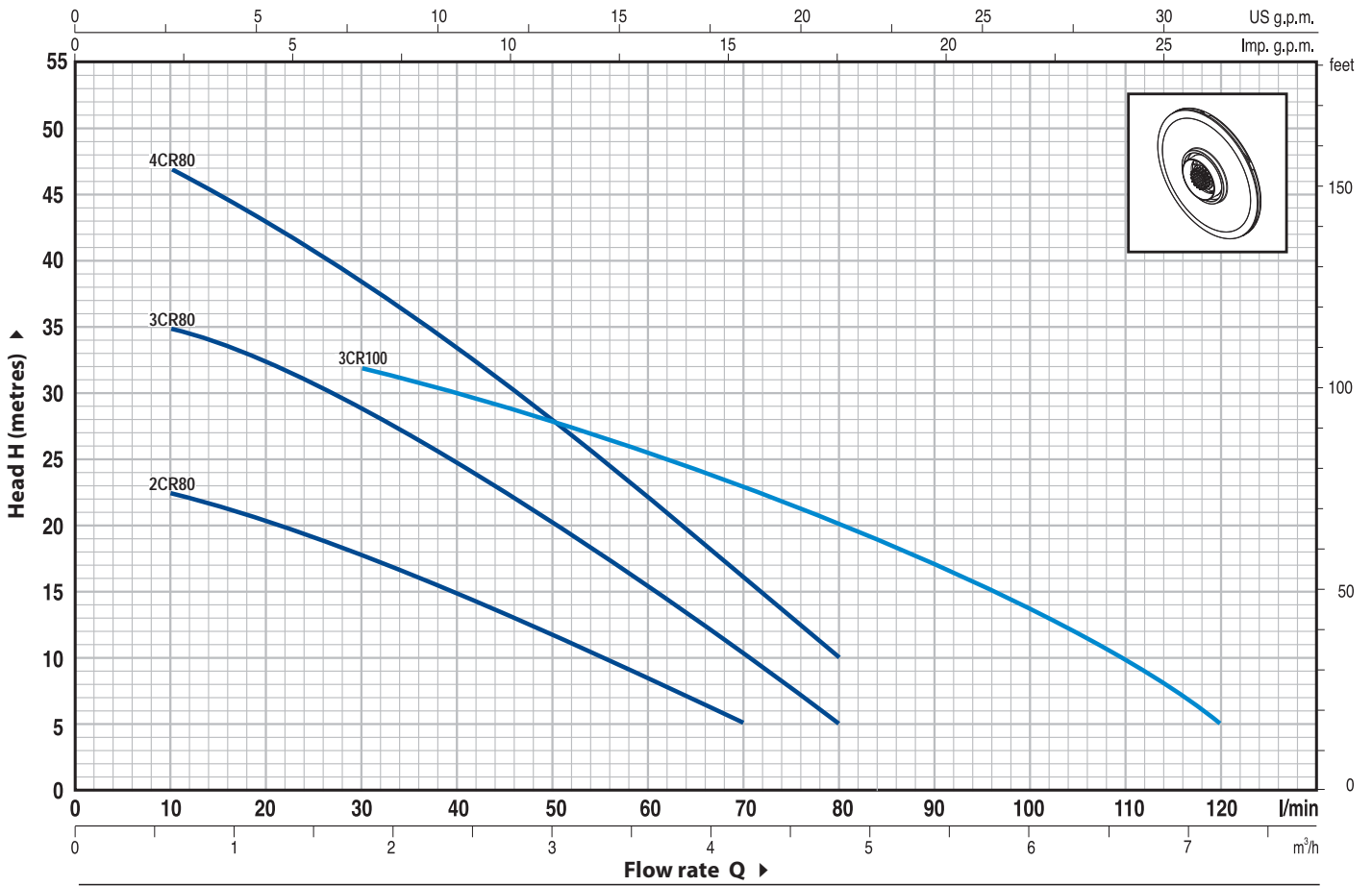

MODEL		POWER		Q	H metres																	
Single-phase	Three-phase	kW	HP		m³/h	0	0.3	0.6	0.9	1.2	1.5	1.8	2.4	3.0	3.6	4.2	4.8	5.4	6.0	6.6	7.2	
				l/min	0	5	10	15	20	25	30	40	50	60	70	80	90	100	110	120		
2CRm 80	-	0.37	0.50	H metres	25	24	22.5	21.5	20	19	17.5	15	11.5	8	5							
3CRm 80	3CR 80	0.45	0.60		38	36	35	34	32.5	31	29	25	20	15.5	10	5						
4CRm 80	4CR 80	0.60	0.85		50	48	47	45	43	40.5	38.5	33.5	28	22.5	16	10						
3CRm 100	3CR 100	0.60	0.85		36	35.5	35	34	33.5	32.5	32	30	28	25.5	23	20	17	13.5	10	5		

Q = Flow rate H = Total manometric head HS = Suction height

Tolerance of characteristic curves in compliance with EN ISO 9906 App. A.

POS.	COMPONENT	CONSTRUCTION CHARACTERISTICS				
1	PUMP BODY	Stainless steel AISI 304, complete with threaded ports in compliance with ISO 228/1				
2	BODY BACKPLATE	Stainless steel AISI 304				
3	IMPELLERS	Noryl GFN2V				
4	MOTOR SHAFT	Stainless steel EN 10088-3 - 1.4104				
5	MECHANICAL SEAL	<i>Seal</i>	<i>Shaft</i>	<i>Materials</i>		
		<i>Model</i>	<i>Diameter</i>	<i>Stationary ring</i>	<i>Rotational ring</i>	<i>Elastomer</i>
		AR-13	Ø 13 mm	Ceramic	Graphite	NBR
6	BEARINGS	6202 ZZ- C3 / 6201 ZZ				
7	CAPACITOR	<i>Pump</i>	<i>Capacitance</i>			
		<i>Single-phase</i>	<i>(230 V or 240 V)</i>	<i>(110 V)</i>		
		2CRm 80	10 µF 450 VL	25 µF 250 VL		
		3CRm 80	12.5 µF 450 VL	30 µF 250 VL		
		4CRm 80 3CRm 100	14 µF 450 VL	30 µF 250 VL		
8	ELECTRIC MOTOR	<p>2÷4CRm: single-phase 230 V - 50 Hz with thermal overload protector built-in to the winding.</p> <p>2÷4CR: three-phase 230/400 V - 50 Hz.</p> <p>⇒ Pumps fitted with the three-phase motor option offer IE2 (IEC 60034-30) class high performance</p> <ul style="list-style-type: none"> - Insulation: F class. - Protection: IP 44. 				

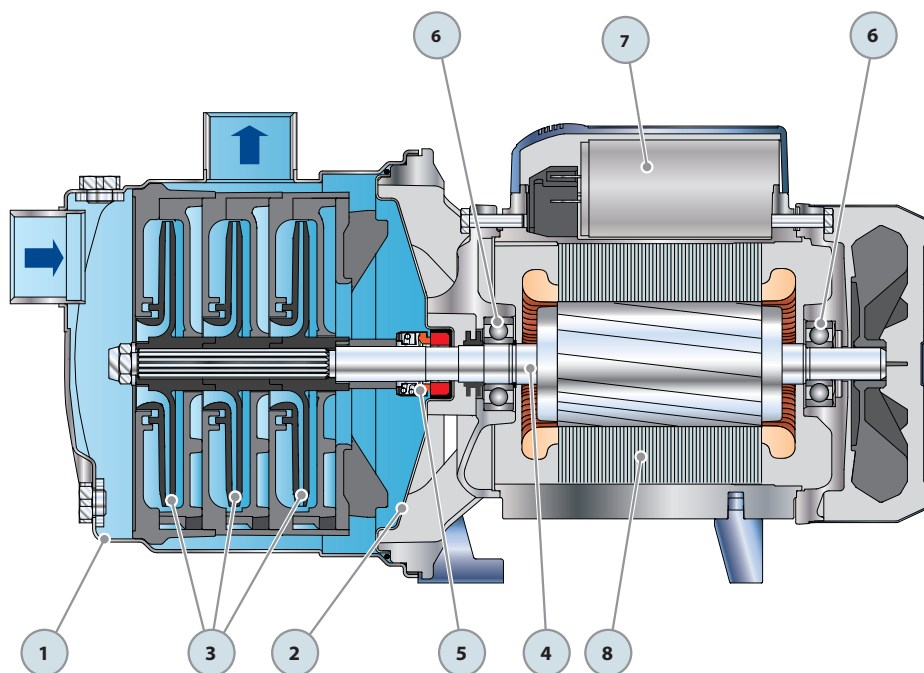

DIMENSIONS AND WEIGHT

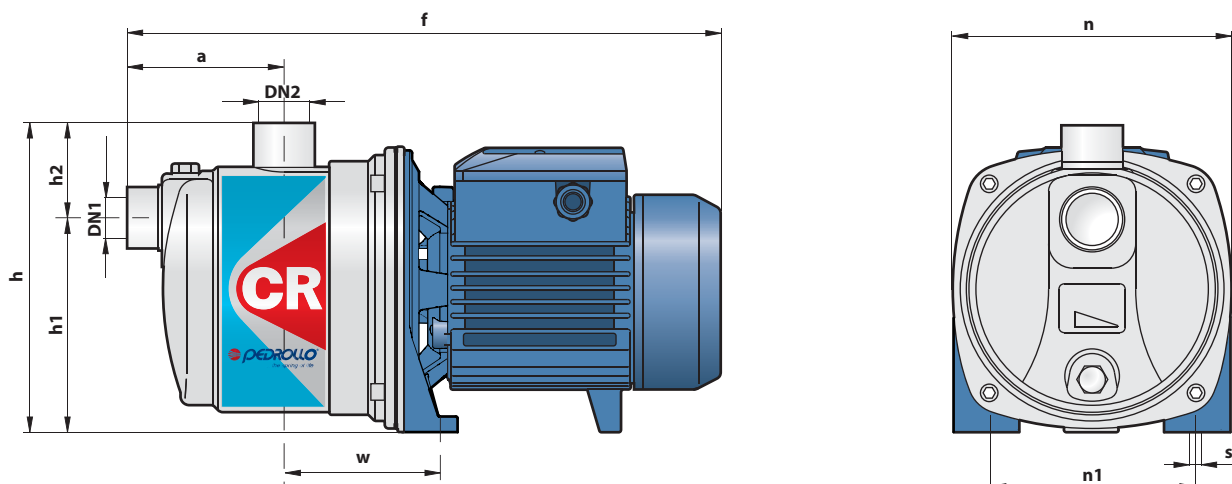

MODEL		PORTS		DIMENSIONS mm									kg	
Single-phase	Three-phase	DN1	DN2	a	f	h	h1	h2	n	n1	w	s	1~	3~
2CRm 80	–	1"	1"	90	345	174	122	52	160	120	88	9	5.9	–
3CRm 80	3CR 80												6.8	6.2
4CRm 80	4CR 80												7.3	6.8
3CRm 100	3CR 100												7.2	6.7

ABSORPTION

MODEL	VOLTAGE (single-phase)		
Single-phase	230 V	240 V	110 V
2CRm 80	2.4 A	2.4 A	4.8 A
3CRm 80	3.2 A	2.9 A	6.5 A
4CRm 80	4.0 A	3.6 A	8.0 A
3CRm 100	4.0A	3.6 A	8.0 A

MODEL	VOLTAGE (three-phase)					
Three-phase	230 V	400 V	690 V	240 V	415 V	720 V
3CR 80	2.2 A	1.3 A	0.8 A	2.1 A	1.2 A	0.7 A
4CR 80	2.9 A	1.7 A	1.0 A	2.8 A	1.6 A	0.9 A
3CR 100	2.9 A	1.7 A	1.0 A	2.8 A	1.6 A	0.9 A

PALLETIZATION

MODEL		GROUPAGE				CONTAINER			
Single-phase	Three-phase	n° pumps	H (mm)	kg		n° pumps	H (mm)	kg	
				1~	3~			1~	3~
2CRm 80	–	98	1440	600	–	154	2180	930	–
3CRm 80	3CR 80	98	1440	690	630	154	2180	1070	970
4CRm 80	4CR 80	98	1440	730	680	154	2180	1140	1070
3CRm 100	3CR 100	98	1440	720	680	154	2180	1130	1050

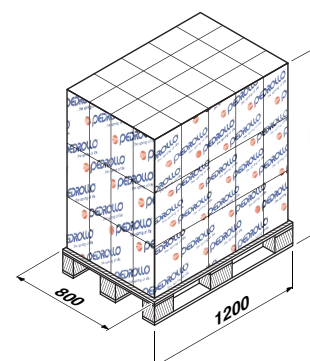



PERFORMANCE RANGE

- Flow rate up to **50 l/min** (3 m³/h)
- Head up to **47 m**

APPLICATION LIMITS

- Manometric suction lift up to **9 m** (HS)
- Liquid temperature between **-10 °C** and **+40 °C**
- Ambient temperature up to **+40 °C**
- Max. working pressure **6 bar**
- Continuous service **S1**

CONSTRUCTION AND SAFETY STANDARDS

EN 60335-1
IEC 60335-1
CEI 61-150

EN 60034-1
IEC 60034-1
CEI 2-3



CERTIFICATIONS



INSTALLATION AND USE

Suitable for use with clean water and liquids that are not chemically aggressive towards the materials from which the pump is made. The self-priming JSW pumps are designed to pump water even in cases where air is present. As a result of their reliability and the fact that they are easy to use, they are recommended for use in domestic applications such as the distribution of water in combination with small or medium sized pressure sets, and for the irrigation of gardens and allotments, etc.

The pump should be installed in an enclosed environment, or at least sheltered from inclement weather.

PATENTS - TRADE MARKS - MODELS

- Registered Italian model n° 72753
- European Patent n° 1 510 696

OPTIONALS AVAILABLE ON REQUEST

- Pumps with technopolymer impeller
- Other voltages or 60 Hz frequency

GUARANTEE

1 year subject to terms and conditions

CHARACTERISTIC CURVES AND PERFORMANCE DATA

50 Hz n= 2900 1/min HS= 0 m

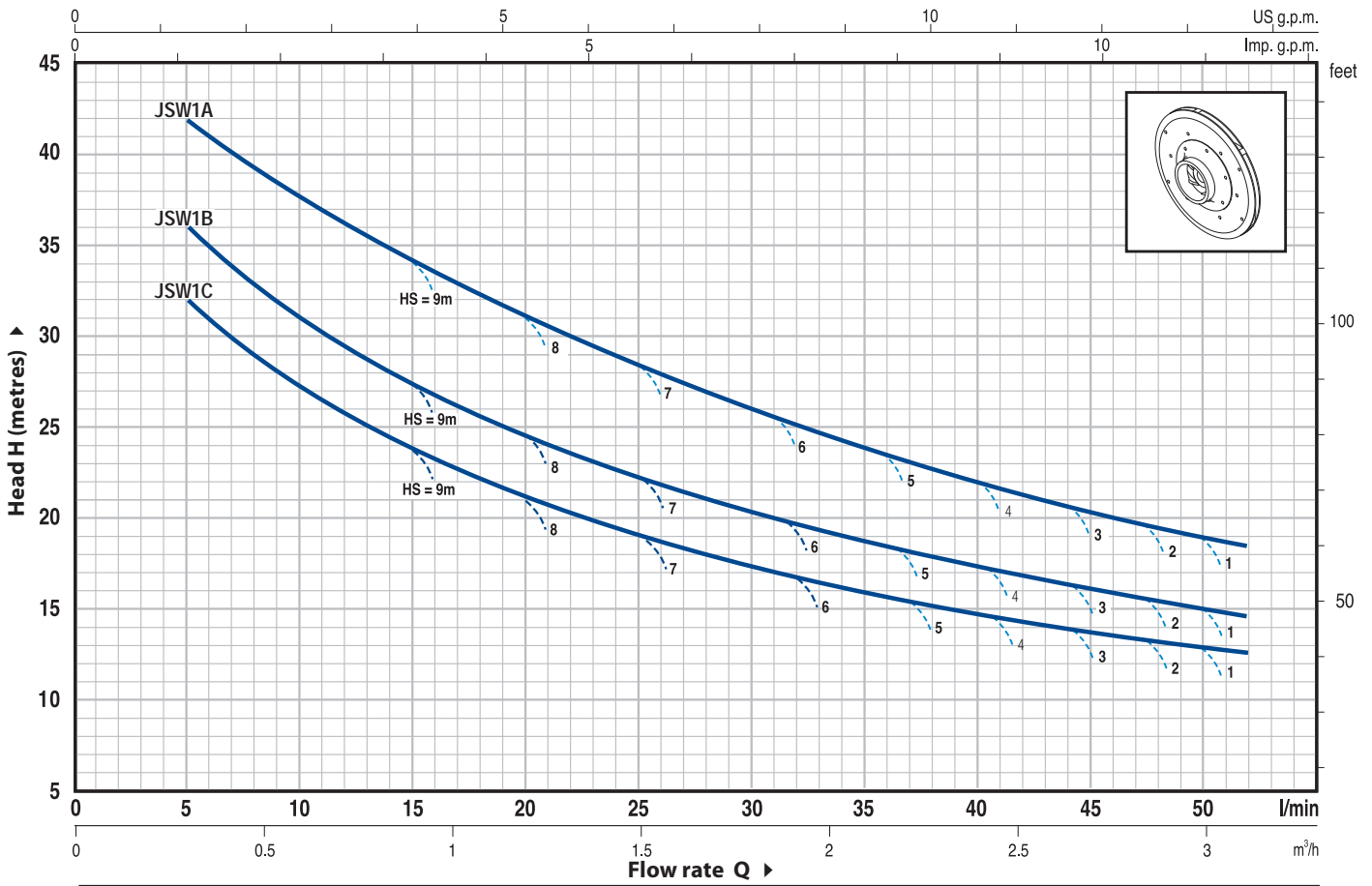

MODEL		POWER		Q	Flow rate														
Single-phase	Three-phase	kW	HP		0	0.3	0.6	0.9	1.2	1.5	1.8	2.1	2.4	2.7	3.0				
JSWm 1C	-	0.37	0.50	H metres	35	32	27	24	21	19	17	16	15	14	13				
JSWm 1B	JSW 1B	0.50	0.70		41	36	31	27	24	22	20	19	17	16	15				
JSWm 1A	JSW 1A	0.60	0.85		47	42	38	34	31	28.5	26	24	22	21.5	19				

Q = Flow rate H = Total manometric head HS = Suction height

Tolerance of characteristic curves in compliance with EN ISO 9906 App. A.

INSTALLATION EXAMPLE

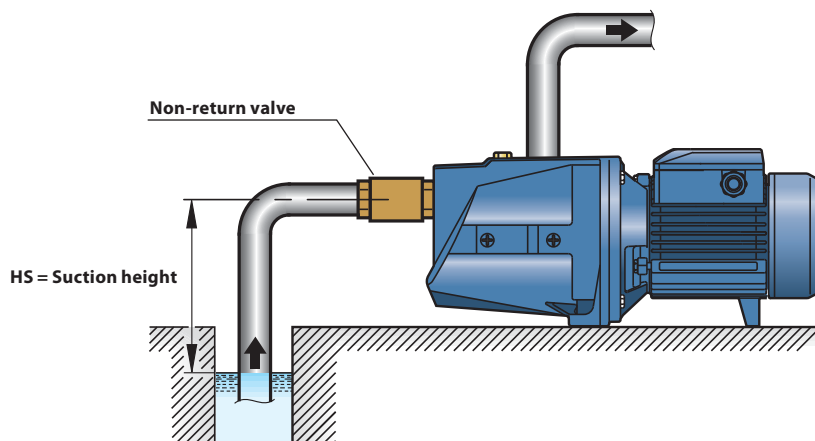

POS.	COMPONENT	CONSTRUCTION CHARACTERISTICS				
1	PUMP BODY	Cast iron, complete with threaded ports in compliance with ISO 228/1				
2	BODY BACKPLATE	Stainless steel AISI 304				
3	NOZZLE ASSEMBLY	Noryl GFN2V				
4	IMPELLER	Brass				
5	MOTOR SHAFT	Stainless steel EN 10088-3 - 1.4104				
6	MECHANICAL SEAL	Seal	Shaft	Materials		
		<i>Model</i>	<i>Diameter</i>	<i>Stationary ring</i>	<i>Rotational ring</i>	<i>Elastomer</i>
		AR-12	Ø 12 mm	Ceramic	Graphite	NBR
7	BEARINGS	6201 ZZ / 6201 ZZ				
8	CAPACITOR	Pump	Capacitance			
		<i>Single-phase</i>	<i>(230 V or 240 V)</i>	<i>(110 V)</i>		
		JSWm 1C	10 µF 450 VL	25 µF 250 VL		
		JSWm 1B	10 µF 450 VL	30 µF 250 VL		
		JSWm 1A	14 µF 450 VL	30 µF 250 VL		
9	ELECTRIC MOTOR	JSWm: single-phase 230 V - 50 Hz with thermal overload protector built-in to the winding. JSW: three-phase 230/400 V - 50 Hz. ⇒ Pumps fitted with the three-phase motor option offer IE2 (IEC 60034-30) class high performance – Insulation: F class. – Protection: IP 44.				

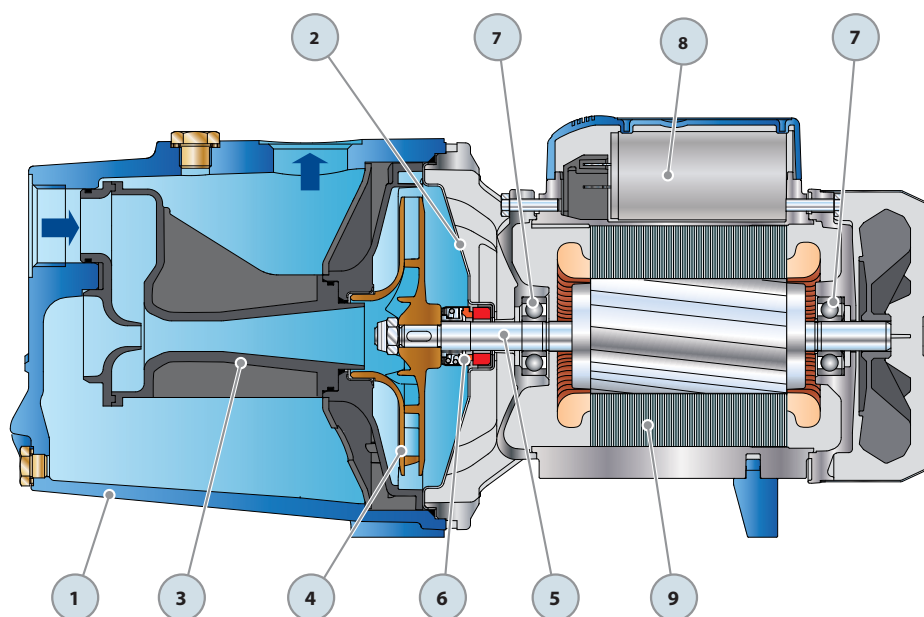

DIMENSIONS AND WEIGHT

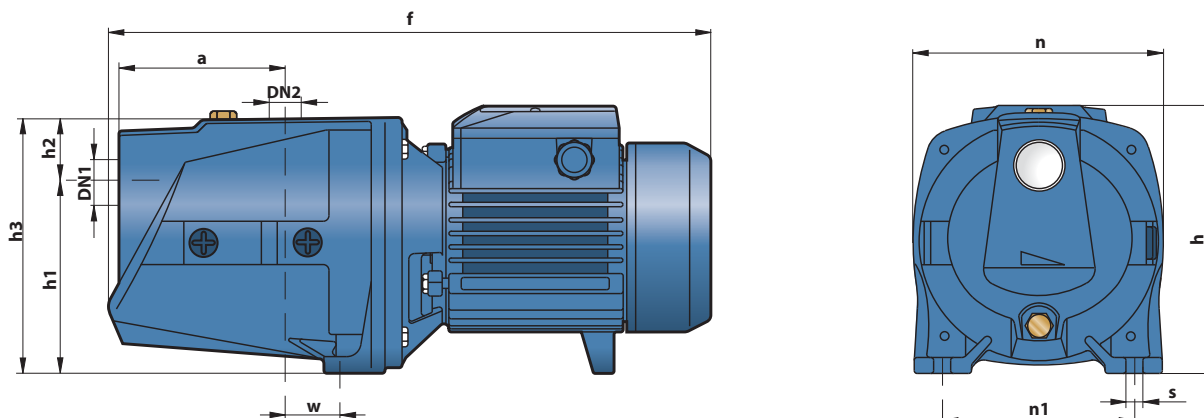

MODEL		PORTS		DIMENSIONS mm										kg	
Single-phase	Three-phase	DN1	DN2	a	f	h	h1	h2	h3	n	n1	w	s	1~	3~
JSWm 1C	–	1"	1"	115	379	171	127	33.5	160.5	160	124	24	10	9.2	–
JSWm 1B	JSW 1B													10.0	9.5
JSWm 1A	JSW 1A													10.3	10.1

ABSORPTION

MODEL	VOLTAGE (single-phase)		
	230 V	240 V	110 V
Single-phase	230 V	240 V	110 V
JSWm 1C	2.4 A	2.2 A	4.8 A
JSWm 1B	3.2 A	2.9 A	6.5 A
JSWm 1A	3.6 A	3.3 A	7.3 A

MODEL	VOLTAGE (three-phase)					
	230 V	400 V	690 V	240 V	415 V	720 V
Three-phase	230 V	400 V	690 V	240 V	415 V	720 V
JSW 1B	2.1 A	1.2 A	0.7 A	2.0 A	1.2 A	0.7 A
JSW 1A	2.8 A	1.6 A	0.9 A	2.7 A	1.6 A	0.9 A

PALLETIZATION

MODEL		GROUPAGE				CONTAINER			
Single-phase	Three-phase	n° pumps	H (mm)	kg		n° pumps	H (mm)	kg	
				1~	3~			1~	3~
JSWm 1C	–	98	1440	920	–	154	2180	1440	–
JSWm 1B	JSW 1B	98	1440	1000	950	154	2180	1560	1480
JSWm 1A	JSW 1A	98	1440	1030	1010	154	2180	1600	1570

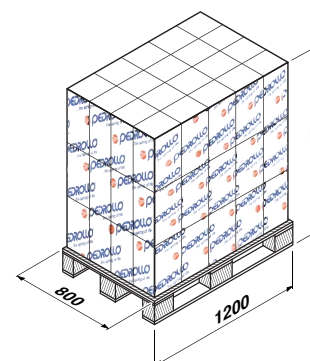



PERFORMANCE RANGE

- Flow rate up to **80 l/min** (4.8 m³/h)
- Head up to **70 m**

APPLICATION LIMITS

- Manometric suction lift up to **9 m** (HS)
- Liquid temperature between **-10 °C** and **+40 °C**
- Ambient temperature up to **+40 °C**
- Max. working pressure **6.5 bar**
- Continuous service **S1**

CONSTRUCTION AND SAFETY STANDARDS

EN 60335-1
IEC 60335-1
CEI 61-150

EN 60034-1
IEC 60034-1
CEI 2-3



CERTIFICATIONS



INSTALLATION AND USE

Suitable for use with clean water and liquids that are not chemically aggressive towards the materials from which the pump is made. The self-priming JSW pumps are designed to pump water even in cases where air is present. As a result of their reliability and the fact that they are easy to use, they are recommended for use in domestic applications such as the distribution of water in combination with small or medium sized pressure sets, and for the irrigation of gardens and allotments, etc.

The pump should be installed in an enclosed environment, or at least sheltered from inclement weather.

PATENTS - TRADE MARKS - MODELS

- Registered Italian model n° 72753
- European Patent n° 1 510 696

OPTIONALS AVAILABLE ON REQUEST

- Pumps with technopolymer impeller
- Other voltages or 60 Hz frequency

GUARANTEE

1 year subject to terms and conditions

CHARACTERISTIC CURVES AND PERFORMANCE DATA

50 Hz n= 2900 1/min HS= 0 m

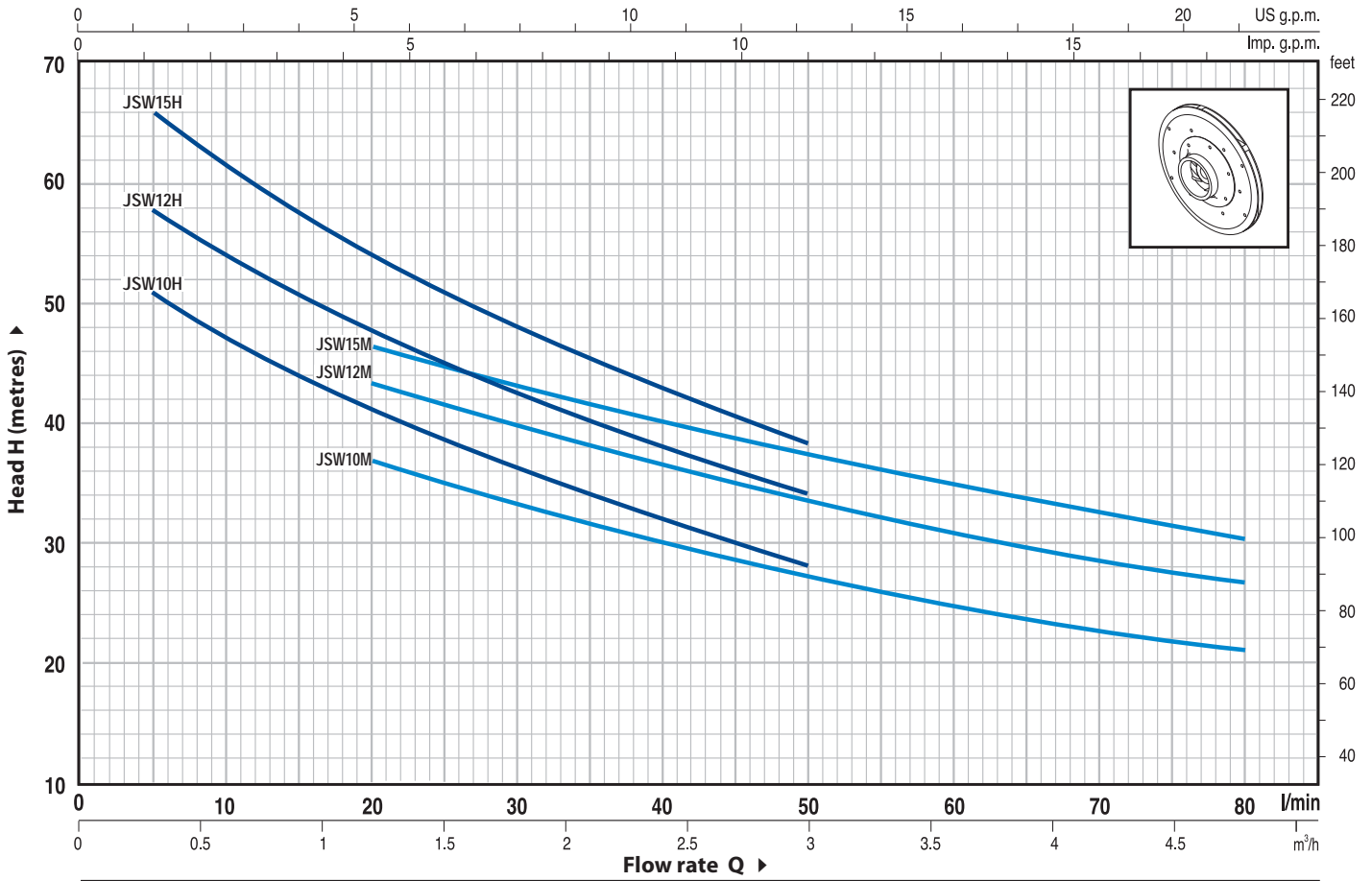

MODEL		POWER		Q	Flow rate																
Single-phase	Three-phase	kW	HP		m³/h	0	0.3	0.6	0.9	1.2	1.5	1.8	2.4	2.7	3.0	3.6	4.2	4.8			
				l/min	0	5	10	15	20	25	30	40	45	50	60	70	80				
JSWm 10H	JSW 10H	0.75	1	H metres	56	51	47	44	41	39	36	32	30	28							
JSWm 12H	JSW 12H	0.90	1.25		64	58	54	51	48	45	43	38	36	34							
JSWm 15H	JSW 15H	1.1	1.5		70	66	62	58	54	51	48	43	41	38							
JSWm 10M	JSW 10M	0.75	1		46	42	40	38	37	35	33	30	29	27	25	23	21				
JSWm 12M	JSW 12M	0.90	1.25		50	48	46	44	42	41	39	36	35	33	31	29	27				
JSWm 15M	JSW 15M	1.1	1.5		55	52	50	48	46	45	43	40	39	37	35	33	30				

Q = Flow rate H = Total manometric head HS = Suction height

Tolerance of characteristic curves in compliance with EN ISO 9906 App. A.

INSTALLATION EXAMPLE

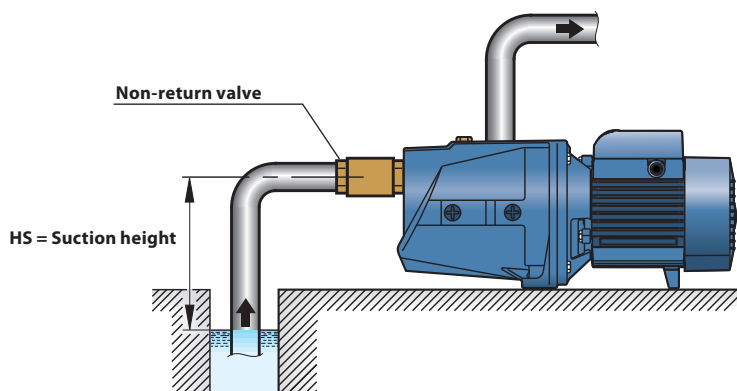

POS.	COMPONENT	CONSTRUCTION CHARACTERISTICS				
1	PUMP BODY	Cast iron, complete with threaded ports in compliance with ISO 228/1				
2	BODY BACKPLATE	Stainless steel AISI 304				
3	NOZZLE ASSEMBLY	Noryl GFN2V				
4	IMPELLER	Brass				
5	MOTOR SHAFT	Stainless steel EN 10088-3 - 1.4104				
6	MECHANICAL SEAL	Seal	Shaft	Materials		
		<i>Model</i>	<i>Diameter</i>	<i>Stationary ring</i>	<i>Rotational ring</i>	<i>Elastomer</i>
		AR-14	Ø 14 mm	Ceramic	Graphite	NBR
7	BEARINGS	6203 ZZ / 6203 ZZ				
8	CAPACITOR	Pump	Capacitance			
		<i>Single-phase</i>	<i>(230 V or 240 V)</i>	<i>(110 V)</i>		
		JSWm 10H-M	20 µF 450 VL	60 µF 300 VL		
		JSWm 12H-M	25 µF 450 VL	60 µF 300 VL		
		JSWm 15H-M	25 µF 450 VL	60 µF 300 VL		
9	ELECTRIC MOTOR	JSWm: single-phase 230 V - 50 Hz with thermal overload protector built-in to the winding. JSW: three-phase 230/400 V - 50 Hz. ⇒ Pumps fitted with the three-phase motor option offer IE2 (IEC 60034-30) class high performance – Insulation: F class. – Protection: IP 44.				

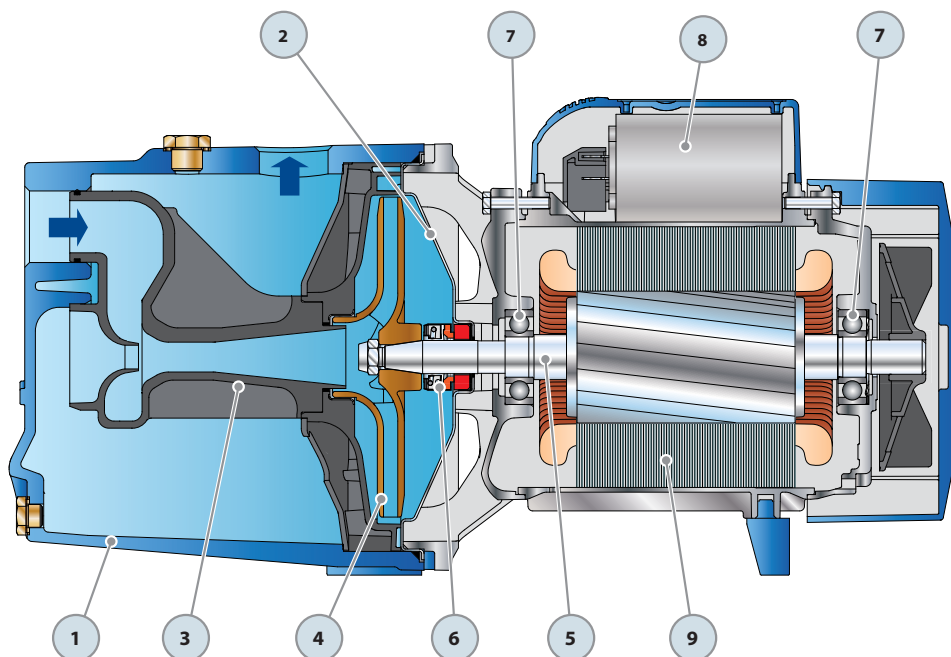

DIMENSIONS AND WEIGHT

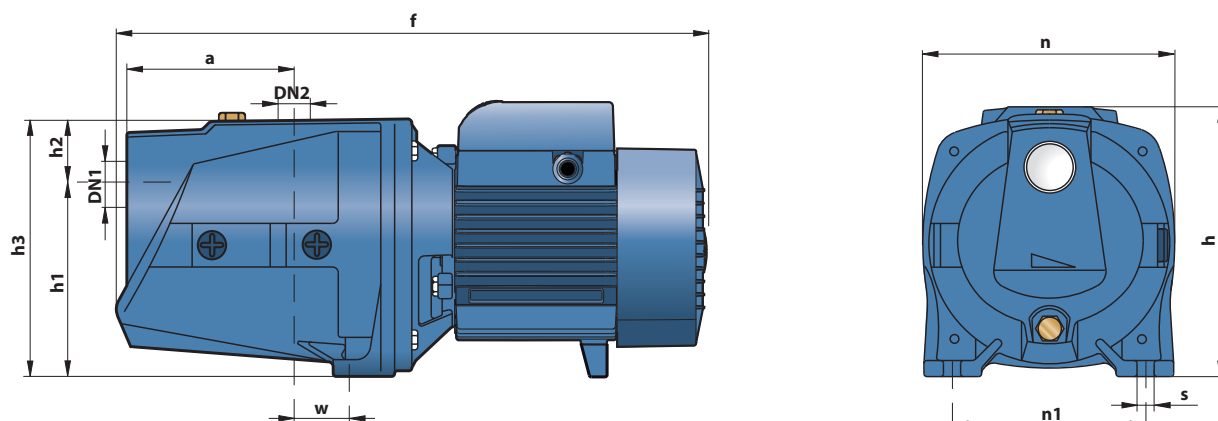

MODEL		PORTS		DIMENSIONS mm										kg	
Single-phase	Three-phase	DN1	DN2	a	f	h	h1	h2	h3	n	n1	w	s	1~	3~
JSWm 10H	JSW 10H	1"	1"	113.5	402	201	147	35	182	180	142	22	10	13.7	13.8
JSWm 12H	JSW 12H													14.7	13.6
JSWm 15H	JSW 15H													15.1	14.8
JSWm 10M	JSW 10M													13.7	13.8
JSWm 12M	JSW 12M													14.7	13.6
JSWm 15M	JSW 15M													15.1	14.8

ABSORPTION

MODEL	VOLTAGE (single-phase)		
	230 V	240 V	110 V
Single-phase	230 V	240 V	110 V
JSWm 10H	4.7 A	4.5 A	9.4 A
JSWm 12H	5.4 A	5.0 A	10.8 A
JSWm 15H	6.6 A	6.0 A	13.2 A
JSWm 10M	5.0 A	4.6 A	10.0 A
JSWm 12M	5.7 A	5.2 A	11.4 A
JSWm 15M	6.6 A	6.0 A	13.2 A

MODEL	VOLTAGE (three-phase)					
	230 V	400 V	690 V	240 V	415 V	720 V
Three-phase	230 V	400 V	690 V	240 V	415 V	720 V
JSW 10H	3.5 A	2.0 A	1.2 A	3.4 A	2.0 A	1.2 A
JSW 12H	4.2 A	2.4 A	1.4 A	4.0 A	2.3 A	1.3 A
JSW 15H	5.5 A	3.2 A	1.8 A	5.3 A	3.1 A	1.8 A
JSW 10M	3.6 A	2.1 A	1.2 A	3.5 A	2.0 A	1.2 A
JSW 12M	4.5 A	2.6 A	1.5 A	4.3 A	2.5 A	1.4 A
JSW 15M	5.5 A	3.2 A	1.8 A	5.3 A	3.1 A	1.8 A

PALLETIZATION

MODEL		GROUPAGE				CONTAINER			
Single-phase	Three-phase	n° pumps	H (mm)	kg		n° pumps	H (mm)	kg	
				1~	3~			1~	3~
JSWm 10H	JSW 10H	72	1460	1000	1010	96	1900	1330	1340
JSWm 12H	JSW 12H	72	1460	1080	1000	96	1900	1430	1330
JSWm 15H	JSW 15H	72	1460	1110	1090	96	1900	1470	1440
JSWm 10M	JSW 10M	72	1460	1000	1010	96	1900	1330	1340
JSWm 12M	JSW 12M	72	1460	1080	1000	96	1900	1430	1330
JSWm 15M	JSW 15M	72	1460	1110	1090	96	1900	1470	1440

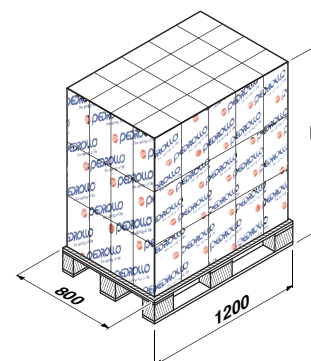



PERFORMANCE RANGE

- Flow rate up to **160 l/min** (9.6 m³/h)
- Head up to **96 m**

APPLICATION LIMITS

- Manometric suction lift up to **9 m** (HS)
- Liquid temperature between **-10 °C** and **+40 °C**
- Ambient temperature between **-10 °C** and **+40 °C**
- Max. working pressure **10 bar**
- Continuous service **S1**

CONSTRUCTION AND SAFETY STANDARDS

EN 60335-1
IEC 60335-1
CEI 61-150

EN 60034-1
IEC 60034-1
CEI 2-3



CERTIFICATIONS



INSTALLATION AND USE

Suitable for use with clean water and liquids that are not chemically aggressive towards the materials from which the pump is made. The self-priming JSW pumps are designed to pump water even in cases where air is present. As a result of their reliability and the fact that they are easy to use, they are recommended for use in domestic, civil and industrial applications such as the distribution of water in combination with pressure sets, and for the irrigation of gardens and allotments, etc.

The pump should be installed in an enclosed environment, or at least sheltered from inclement weather.

PATENTS - TRADE MARKS - MODELS

- Registered Italian model n° 72753

OPTIONALS AVAILABLE ON REQUEST

- Special mechanical seal
- Other voltages or 60 Hz frequency
- IP55 class protection

GUARANTEE

1 year subject to terms and conditions

CHARACTERISTIC CURVES AND PERFORMANCE DATA

50 Hz n= 2900 1/min HS= 0 m

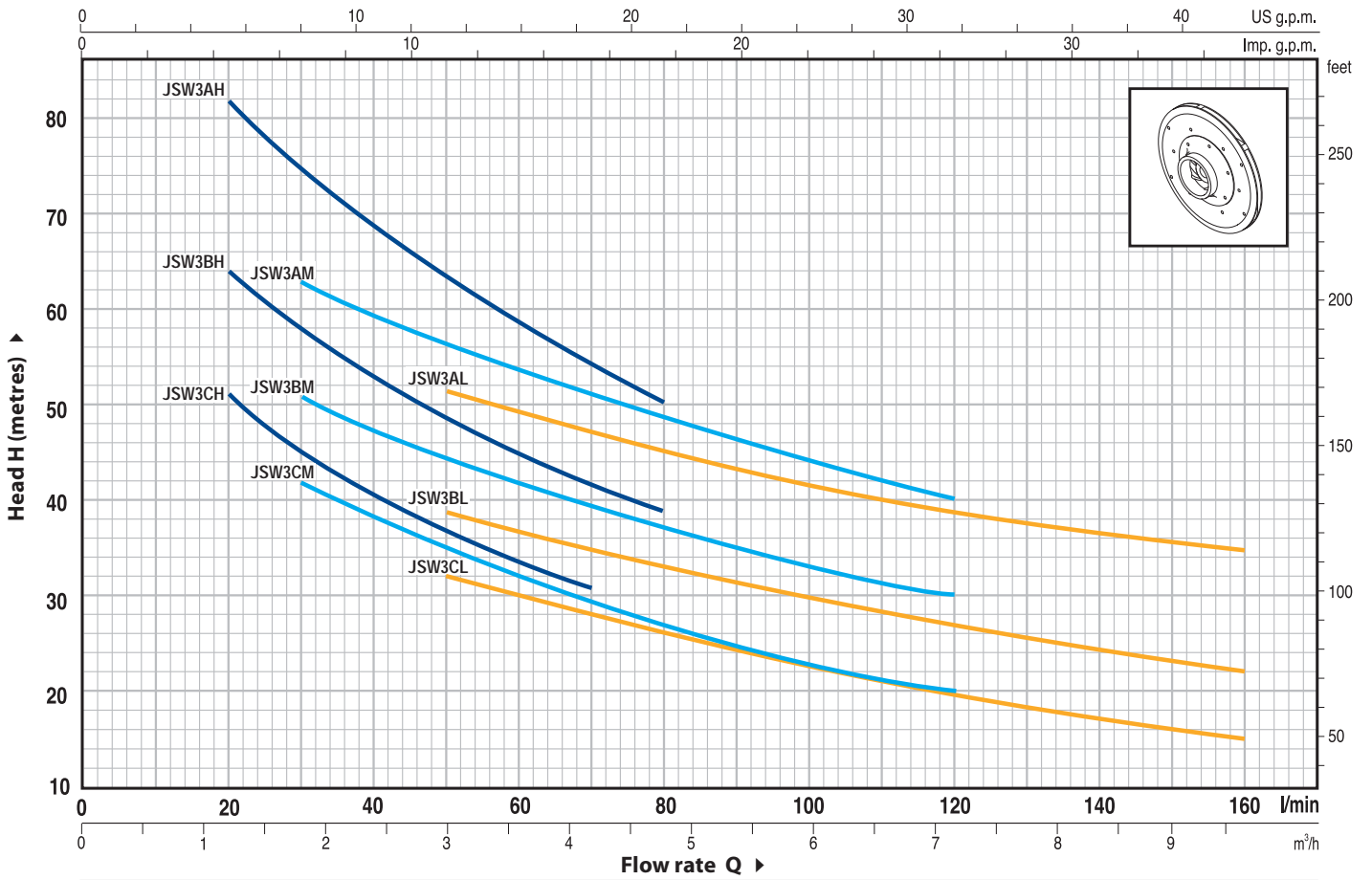

MODEL		POWER		Q	Flow rate																		
Single-phase	Three-phase	kW	HP		m³/h	0	0.6	0.9	1.2	1.5	1.8	2.1	2.4	2.7	3.0	3.6	4.2	4.8	6.0	7.2	8.4	9.6	
				l/min	0	10	15	20	25	30	35	40	45	50	60	70	80	100	120	140	160		
JSWm 3CH	JSW 3CH	1.1	1.5	H metres	64	60	55	51	48	45	42.5	40	39	37	34	31							
JSWm 3BH	JSW 3BH	1.5	2		76	70	67	64	61	58	55.5	53	51	49	45	41	39						
-	JSW 3AH	2.2	3		96	90	86	82	79	75	71.5	69	66	64	58	54	50						
JSWm 3CM	JSW 3CM	1.1	1.5		52	50	48	45	44	42	40	38	37	35	32	29	27	23	20				
JSWm 3BM	JSW 3BM	1.5	2		60	58	56	54	52	51	49	47	46	45	42	39	37	33	30				
-	JSW 3AM	2.2	3		74	70	68	67	65	63	61	59	58	56	54	51	49	44	40				
JSWm 3CL	JSW 3CL	1.1	1.5		42	40	39	38	37	36	35	34	33	32	30	28	26	23	20	17	15		
JSWm 3BL	JSW 3BL	1.5	2		51	48	46	45	44	43	42	41	40	39	37	35	33	30	27	24	22		
-	JSW 3AL	2.2	3		62	60	58	57	56	55	54	53	52	51	49	47	45	42	39	36.5	35		

Q = Flow rate H = Total manometric head HS = Suction height

Tolerance of characteristic curves in compliance with EN ISO 9906 App. A.

INSTALLATION EXAMPLE

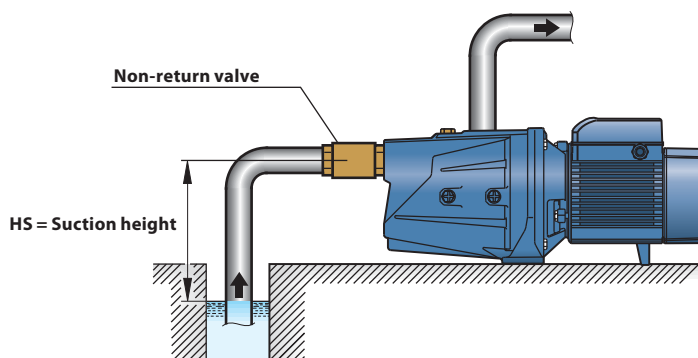

POS.	COMPONENT	CONSTRUCTION CHARACTERISTICS				
1	PUMP BODY	Cast iron, complete with threaded ports in compliance with ISO 228/1				
2	BODY BACKPLATE	Cast iron				
3	NOZZLE ASSEMBLY	Noryl GFN2V				
4	IMPELLER	Brass				
5	MOTOR SHAFT	Stainless steel EN 10088-3 - 1.4104				
6	MECHANICAL SEAL	Seal	Shaft	Materials		
		<i>Model</i>	<i>Diameter</i>	<i>Stationary ring</i>	<i>Rotational ring</i>	<i>Elastomer</i>
		FN-18	Ø 18 mm	Graphite	Ceramic	NBR
7	BEARINGS	6204 ZZ / 6204 ZZ				
8	CAPACITOR	Pump	Capacitance			
		<i>Single-phase</i>	<i>(230 V or 240 V)</i>	<i>(110 V)</i>		
		JSWm 3C	31.5 µF 450 VL	60 µF 250 VL		
		JSWm 3B	45 µF 450 VL	80 µF 250 VL		
9	ELECTRIC MOTOR	JSWm: single-phase 230 V - 50 Hz with thermal overload protector built-in to the winding. JSW: three-phase 230/400 V - 50 Hz. ⇒ Pumps fitted with the three-phase motor option offer IE2 (IEC 60034-30) class high performance – Insulation: F class. – Protection: IP 44.				

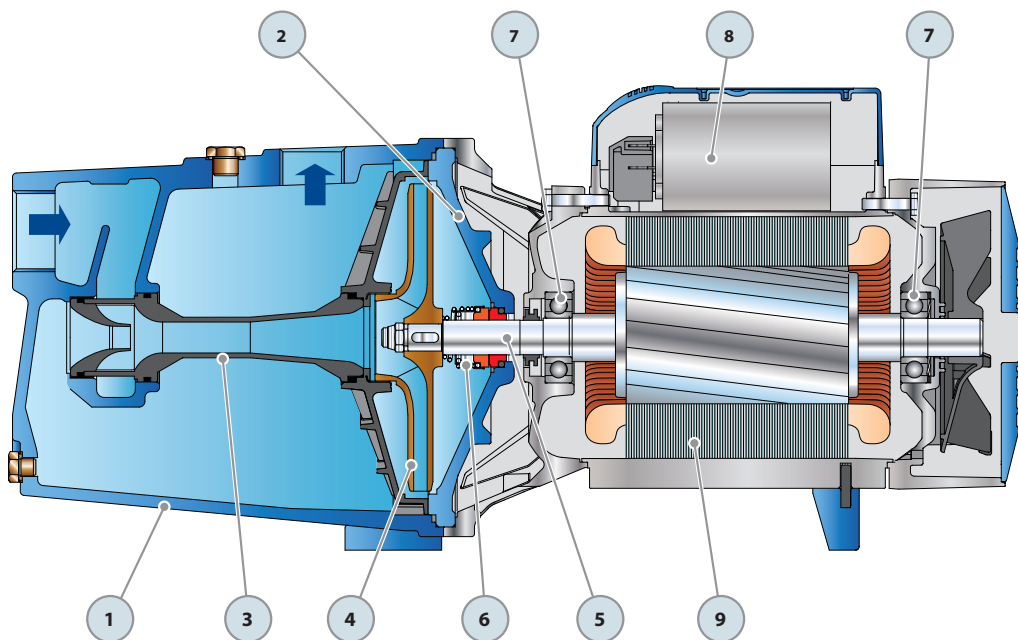

DIMENSIONS AND WEIGHT

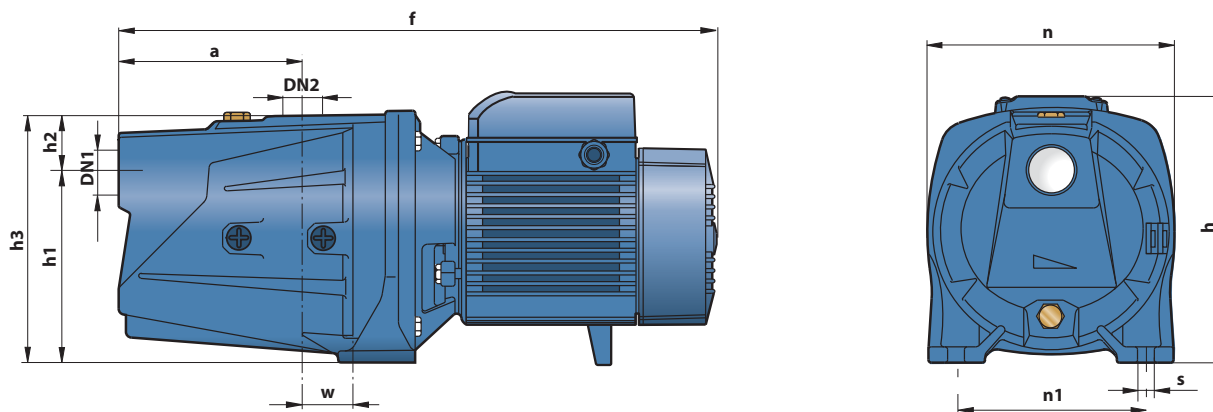

MODEL		PORTS		DIMENSIONS mm										kg	
Single-phase	Three-phase	DN1	DN2	a	f	h	h1	h2	h3	n	n1	w	s	1~	3~
JSWm 3CH	JSW 3CH	1 1/4"	1"	155	530	242	165	43	208	206	164	30	11	24.9	22.9
JSWm 3BH	JSW 3BH													26.1	25.1
-	JSW 3AH													-	26.4
JSWm 3CM	JSW 3CM													24.9	22.9
JSWm 3BM	JSW 3BM													26.1	25.1
-	JSW 3AM													-	26.4
JSWm 3CL	JSW 3CL													24.9	22.9
JSWm 3BL	JSW 3BL													26.1	25.1
-	JSW 3AL													-	26.4

ABSORPTION

MODEL	VOLTAGE (single-phase)		
	230 V	240 V	110 V
JSWm 3CH	8.0 A	7.3 A	16.0 A
JSWm 3BH	9.0 A	8.2 A	18.0 A
JSWm 3CM	7.9 A	7.2 A	15.8 A
JSWm 3BM	9.3 A	8.5 A	18.6 A
JSWm 3CL	7.5 A	6.9 A	15.0 A
JSWm 3BL	9.7 A	9.0 A	19.4 A

MODEL	VOLTAGE (three-phase)					
	230 V	400 V	690 V	240 V	415 V	720 V
JSW 3CH	5.5 A	3.2 A	1.8 A	5.3 A	3.1 A	1.8 A
JSW 3BH	6.9 A	4.0 A	2.3 A	6.6 A	3.8 A	2.2 A
JSW 3AH	9.0 A	5.2 A	3.0 A	8.6 A	5.0 A	2.9 A
JSW 3CM	5.9 A	3.4 A	2.0 A	5.7 A	3.3 A	1.9 A
JSW 3BM	7.3 A	4.2 A	2.4 A	7.0 A	4.0 A	2.3 A
JSW 3AM	9.5 A	5.5 A	3.2 A	9.1 A	5.3 A	3.1 A
JSW 3CL	5.5 A	3.2 A	1.8 A	5.3 A	3.1 A	1.8 A
JSW 3BL	7.3 A	4.2 A	2.4 A	7.0 A	4.0 A	2.3 A
JSW 3AL	9.0 A	5.2 A	3.0 A	8.6 A	5.0 A	2.9 A

PALLETIZATION

MODEL		GROUPAGE				CONTAINER			
Single-phase	Three-phase	n° pumps	H (mm)	kg		n° pumps	H (mm)	kg	
				1~	3~			1~	3~
JSWm 3CH	JSW 3CH	35	1420	890	820	49	1930	1240	1140
JSWm 3BH	JSW 3BH	35	1420	930	900	49	1930	1300	1250
-	JSW 3AH	35	1420	-	941	49	1930	-	1310
JSWm 3CM	JSW 3CM	35	1420	890	820	49	1930	1240	1140
JSWm 3BM	JSW 3BM	35	1420	930	900	49	1930	1300	1250
-	JSW 3AM	35	1420	-	941	49	1930	-	1310
JSWm 3CL	JSW 3CL	35	1420	890	820	49	1930	1240	1140
JSWm 3BL	JSW 3BL	35	1420	930	900	49	1930	1300	1250
-	JSW 3AL	35	1420	-	941	49	1930	-	1310

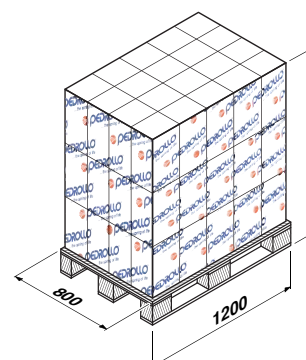



PERFORMANCE RANGE

- Flow rate up to **80 l/min** (4.8 m³/h)
- Head up to **72 m**

APPLICATION LIMITS

- Manometric suction lift up to **9 m** (HS)
- Liquid temperature between **-10 °C** and **+40 °C**
- Ambient temperature up to **+40 °C**
- Max. working pressure **6.5 bar**
- Continuous service **S1**

CONSTRUCTION AND SAFETY STANDARDS

EN 60335-1
IEC 60335-1
CEI 61-150

EN 60034-1
IEC 60034-1
CEI 2-3



CERTIFICATIONS



INSTALLATION AND USE

Suitable for use with clean water and liquids that are not chemically aggressive towards the materials from which the pump is made. The self-priming JCR pumps are designed to pump water even in cases where air is present. As a result of their reliability and the fact that they are easy to use, they are recommended for use in domestic applications such as the distribution of water in combination with small or medium sized pressure sets, and for the irrigation of gardens and allotments, etc.

The pump should be installed in an enclosed environment, or at least sheltered from inclement weather.

PATENTS - TRADE MARKS - MODELS

- European Patent n° 1 510 696

OPTIONALS AVAILABLE ON REQUEST

- Other voltages or 60 Hz frequency

GUARANTEE

1 year subject to terms and conditions

CHARACTERISTIC CURVES AND PERFORMANCE DATA

50 Hz n= 2900 1/min HS= 0 m

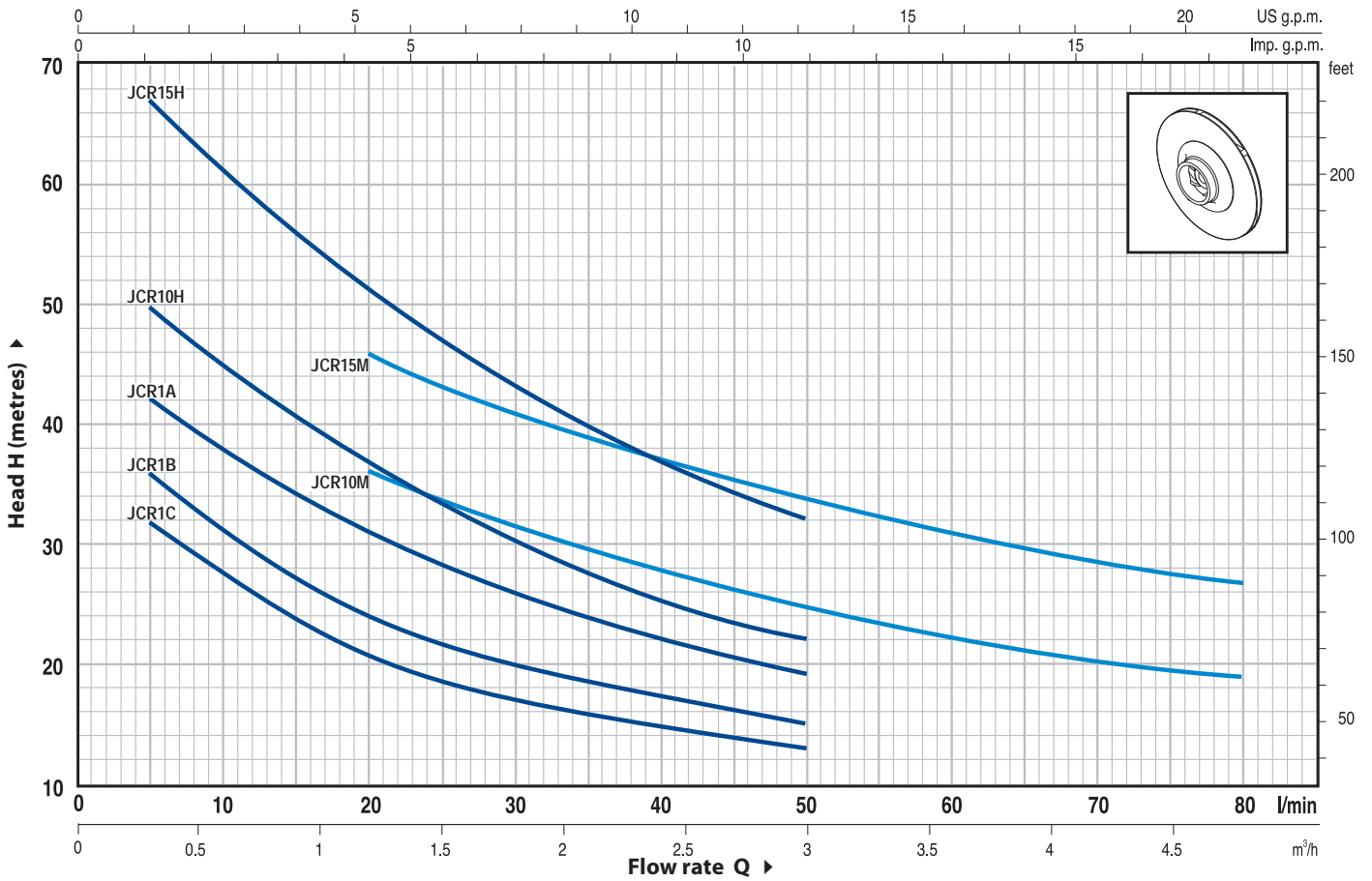

MODEL		POWER		Q	Flow rate															
Single-phase	Three-phase	kW	HP		m³/h	0	0.3	0.6	0.9	1.2	1.5	1.8	2.1	2.4	3.0	3.6	4.2	4.8		
				l/min	0	5	10	15	20	25	30	35	40	50	60	70	80			
JCRm 1C	-	0.37	0.50	H metres	35	32	27	24	21	19	17	16	15	13						
JCRm 1B	JCR 1B	0.50	0.70		41	36	31	27	24	22	20	19	17	15						
JCRm 1A	JCR 1A	0.60	0.85		47	42	38	34	31	28.5	26	24	22	19						
JCRm 10H	JCR 10H	0.75	1		56	50	45	41	37	33	30	27	25	22						
JCRm 15H	JCR 15H	1.1	1.5		72	67	61	56	51	47	43	40	37	32						
JCRm 10M	JCR 10M	0.75	1		46	44	41	39	37	35	32	30	28	25	22	21	19			
JCRm 15M	JCR 15M	1.1	1.5		55	53	50	48	46	43	41	39	37	34	31	29	27			

Q = Flow rate H = Total manometric head HS = Suction height

Tolerance of characteristic curves in compliance with EN ISO 9906 App. A.

INSTALLATION EXAMPLE

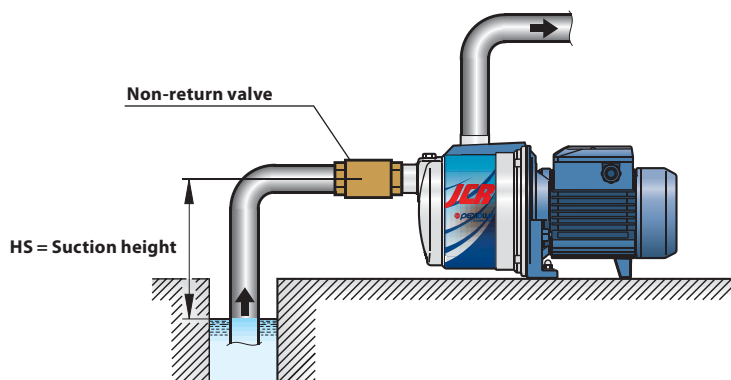

POS.	COMPONENT	CONSTRUCTION CHARACTERISTICS					
1	PUMP BODY	Stainless steel AISI 304, complete with threaded ports in compliance with ISO 228/1					
2	BODY BACKPLATE	Stainless steel AISI 304					
3	NOZZLE ASSEMBLY	Noryl GFN2V					
4	IMPELLER	Noryl GFN2V					
5	MOTOR SHAFT	Stainless steel EN 10088-3 - 1.4104					
6	MECHANICAL SEAL	Pump	Seal	Shaft	Materials		
		<i>Model</i>	<i>Model</i>	<i>Diameter</i>	<i>Stationary ring</i>	<i>Rotational ring</i>	<i>Elastomer</i>
		JCR 1C-B-A	AR-12	Ø 12 mm	Ceramic	Graphite	NBR
		JCR 10-15	AR-14	Ø 14 mm	Ceramic	Graphite	NBR
7	BEARINGS	Pump	Model				
		JCR 1C-B-A	6201 ZZ / 6201 ZZ				
		JCR 10H-M / 15H-M	6203 ZZ / 6203 ZZ				
8	CAPACITOR	Pump	Capacitance				
		<i>Single-phase</i>	<i>(230 V or 240 V)</i>		<i>(110 V)</i>		
		JCRm 1C	10 µF 450 VL	25 µF 250 VL			
		JCRm 1B	10 µF 450 VL	30 µF 250 VL			
		JCRm 1A	14 µF 450 VL	30 µF 250 VL			
		JCRm 10H-M	20 µF 450 VL	60 µF 300 VL			
		JCRm 15H-M	25 µF 450 VL	60 µF 300 VL			

- 9 ELECTRIC MOTOR JCRm: single-phase 230 V - 50 Hz with thermal overload protector built-in to the winding.
 JCR: three-phase 230/400 V - 50 Hz.
- ⇒ Pumps fitted with the three-phase motor option offer IE2 (IEC 60034-30) class high performance
- Insulation: F class.
 - Protection: IP 44.

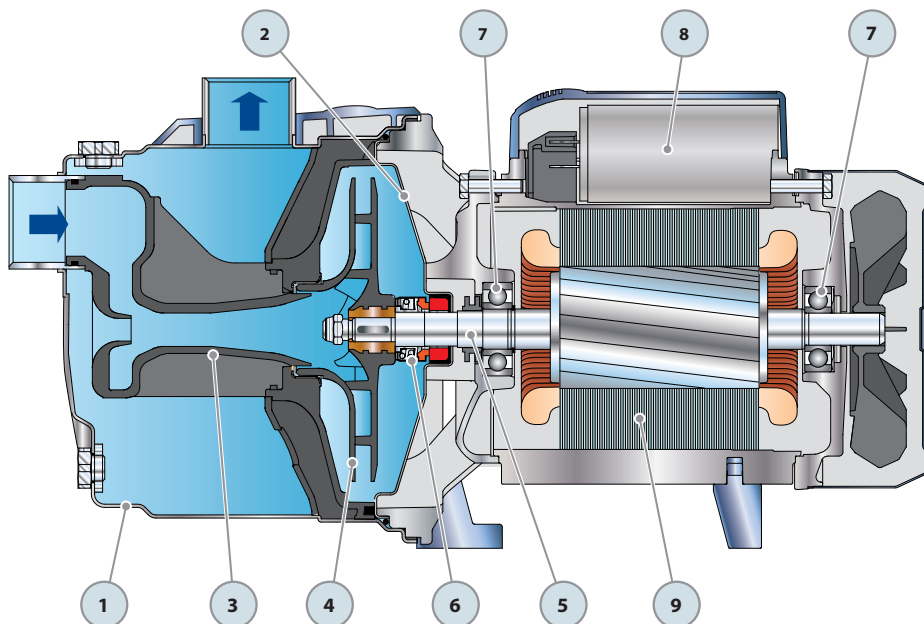

DIMENSIONS AND WEIGHT

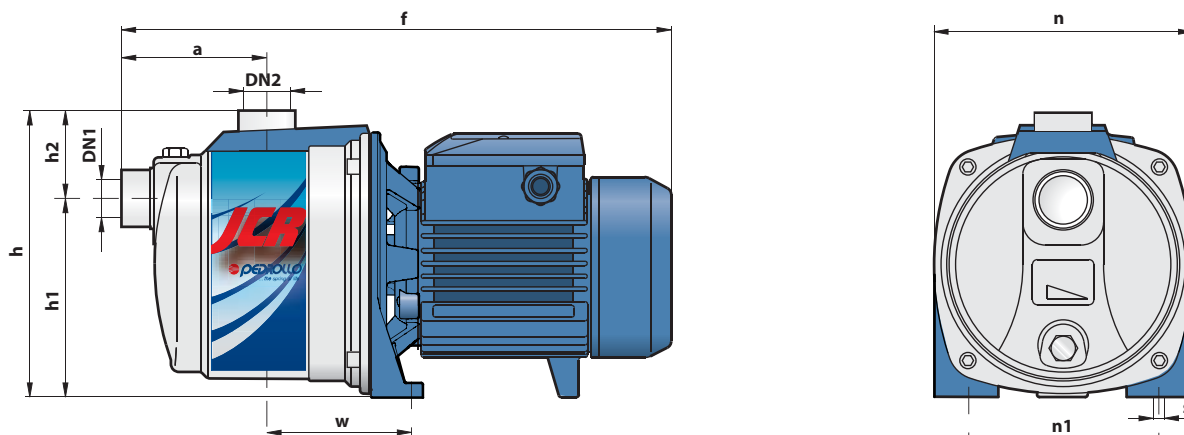

MODEL		PORTS		DIMENSIONS mm									kg	
Single-phase	Three-phase	DN1	DN2	a	f	h	h1	h2	n	n1	w	s	1~	3~
JCRm 1C	–												5.6	–
JCRm 1B	JCR 1B	1"	1"	90	345	174	122	52	160	120	88	9	6.4	6.3
JCRm 1A	JCR 1A												6.9	6.4
JCRm 10H-M	JCR 10H-M	1¼"	1"										9.4	9.3
JCRm 15H-M	JCR 15H-M			117	406	206	145	55	184	135	110	10	10.5	10.3

ABSORPTION

MODEL	VOLTAGE (single-phase)		
	230 V	240 V	110 V
JCRm 1C	2.4 A	2.2 A	4.8 A
JCRm 1B	3.2 A	2.9 A	6.5 A
JCRm 1A	3.6 A	3.3 A	7.3 A
JCRm 10H	4.7 A	4.5 A	9.4 A
JCRm 15H	6.6 A	6.0 A	13.2 A
JCRm 10M	5.0 A	4.6 A	10.0 A
JCRm 15M	6.6 A	6.0 A	13.2 A

MODEL	VOLTAGE (three-phase)					
	230 V	400 V	690 V	240 V	415 V	720 V
JCR 1B	2.1 A	1.2 A	0.7 A	2.0 A	1.2 A	0.7 A
JCR 1A	2.8 A	1.6 A	0.9 A	2.7 A	1.6 A	0.9 A
JCR 10H	3.5 A	2.0 A	1.2 A	3.4 A	2.0 A	1.2 A
JCR 15H	5.5 A	3.2 A	1.8 A	5.3 A	3.1 A	1.8 A
JCR 10M	3.6 A	2.1 A	1.2 A	3.5 A	2.0 A	1.2 A
JCR 15M	5.5 A	3.2 A	1.8 A	5.3 A	3.1 A	1.8 A

PALLETIZATION

MODEL		GROUPAGE				CONTAINER			
Single-phase	Three-phase	n° pumps	H (mm)	kg		n° pumps	H (mm)	kg	
				1~	3~			1~	3~
JCRm 1C	–	98	1440	570	–	154	2180	880	–
JCRm 1B	JCR 1B	98	1440	650	640	154	2180	1010	990
JCRm 1A	JCR 1A	98	1440	700	650	154	2180	1080	1010
JCRm 10H-M	JCR 10H-M	72	1460	700	690	96	1900	920	910
JCRm 15H-M	JCR 15H-M	72	1460	780	760	96	1900	1030	1010

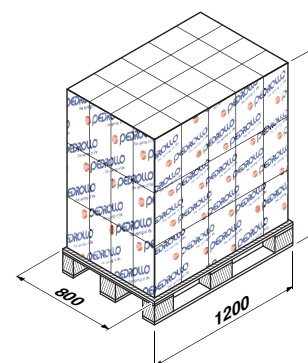

PLURIJET 80-100

Self-priming multi-stage pumps



PERFORMANCE RANGE

- Flow rate up to **130 l/min** (7.8 m³/h)
- Head up to **50 m**

APPLICATION LIMITS

- Manometric suction lift up to **9 m** (HS)
- Liquid temperature between **-10 °C** and **+40 °C**
- Ambient temperature up to **+40 °C**
- Max. working pressure **6 bar**
- Continuous service **S1**

CONSTRUCTION AND SAFETY STANDARDS

EN 60335-1
IEC 60335-1
CEI 61-150

EN 60034-1
IEC 60034-1
CEI 2-3



CERTIFICATIONS



INSTALLATION AND USE

Suitable for use with clean water even where air is present and with liquids that are not chemically aggressive towards the materials from which the pump is made.

The self-priming "PLURIJET" pumps are designed to pump water even in cases where air is present. As a result of their quietness, reliability and low energy consumption they are recommended for use in domestic and civil applications such as the pressurisation and distribution of water in combination with pressure sets, and in rain water recovery and irrigation systems, etc.

The pump should be installed in an enclosed environment, or at least sheltered from inclement weather.

PATENTS - TRADE MARKS - MODELS

- PLURIJET® is a registered trade mark
- Registered Community Design n° 342159-0006

OPTIONALS AVAILABLE ON REQUEST

- Other voltages or 60 Hz frequency

GUARANTEE

1 year subject to terms and conditions

CHARACTERISTIC CURVES AND PERFORMANCE DATA

50 Hz n= 2900 1/min HS= 0 m

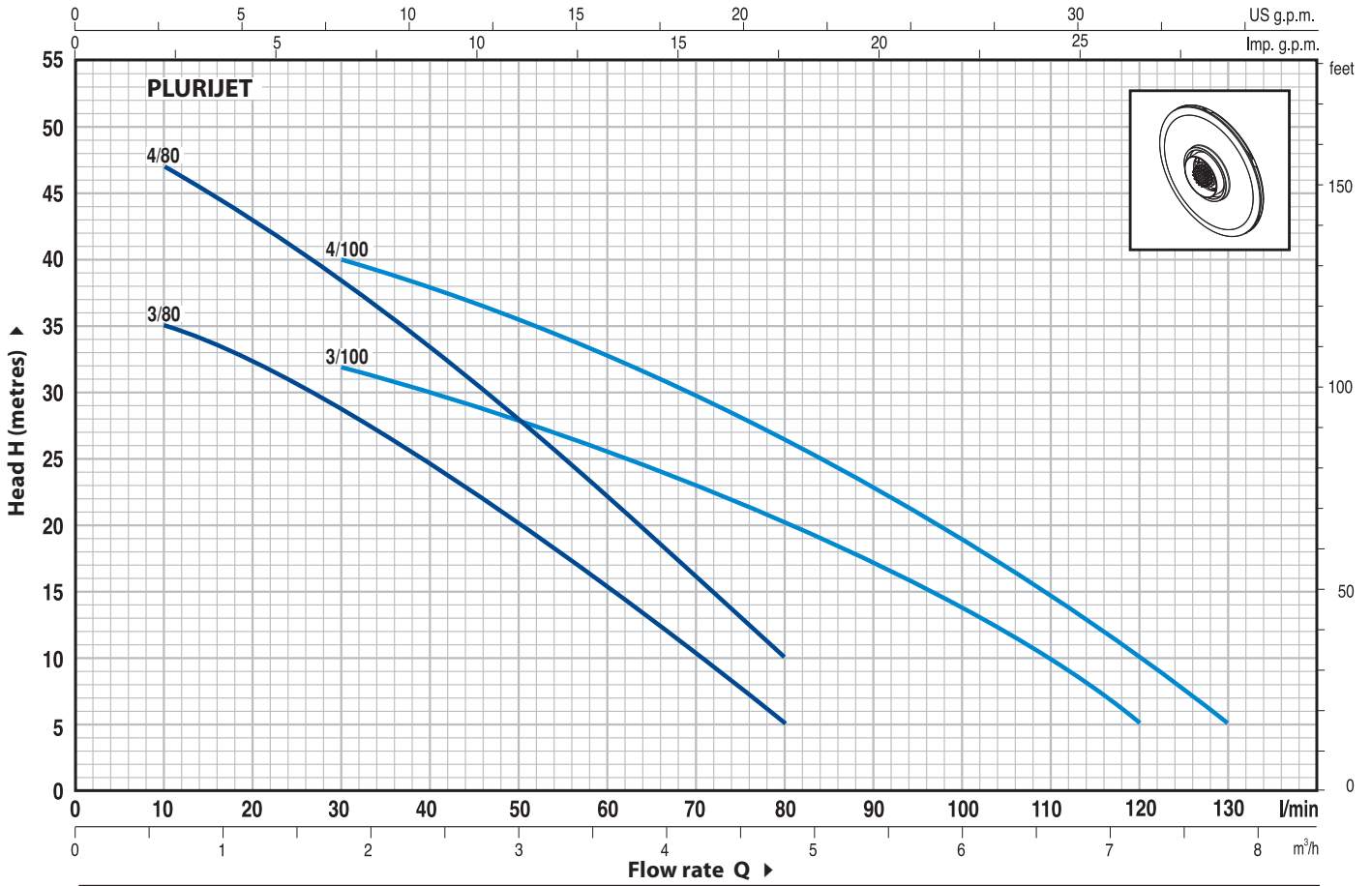

MODEL		POWER		Q													
Single-phase	Three-phase	kW	HP	m ³ /h	0	0.3	0.6	1.2	1.8	2.4	3.0	3.6	4.2	4.8	6.0	7.2	7.8
				l/min	0	5	10	20	30	40	50	60	70	80	100	120	130
PLURIJETm 3/80	-	0.45	0.60	H metres	38	36	35	33.5	29	25	20	15.5	10.5	5			
PLURIJETm 4/80	PLURIJET 4/80	0.60	0.85		50	48	47	43	38.5	33.5	28	22.5	16	10			
PLURIJETm 3/100	PLURIJET 3/100	0.60	0.85		36	35.5	35	33.5	32	30	28	26	23	20	13.5	5	
PLURIJETm 4/100	PLURIJET 4/100	0.75	1		46	45	44	42	40	38	35.5	33	30	26.5	19	10	5

Q = Flow rate H = Total manometric head HS = Suction height

Tolerance of characteristic curves in compliance with EN ISO 9906 App. A.

INSTALLATION EXAMPLE

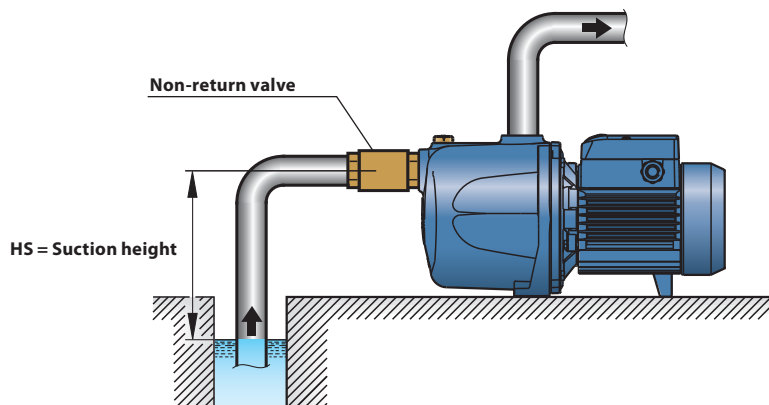

PLURIJET 80-100

POS.	COMPONENT	CONSTRUCTION CHARACTERISTICS				
1	PUMP BODY	Cast iron, complete with threaded ports in compliance with ISO 228/1				
2	BODY BACKPLATE	Stainless steel AISI 304				
3	IMPELLERS	Noryl GFN2V				
4	MOTOR SHAFT	Stainless steel EN 10088-3 - 1.4104				
5	MECHANICAL SEAL	<i>Seal</i>	<i>Shaft</i>	<i>Materials</i>		
		<i>Model</i>	<i>Diameter</i>	<i>Stationary ring</i>	<i>Rotational ring</i>	<i>Elastomer</i>
		AR-13	Ø 13 mm	Ceramic	Graphite	NBR
6	BEARINGS	<i>Pump</i>	<i>Model</i>			
		PLURIJET 3/80				
		PLURIJET 3/100	6202 ZZ - C3 / 6201 ZZ			
		PLURIJET 4/80				
		PLURIJET 4/100	6203 ZZ / 6203 ZZ			
7	CAPACITOR	<i>Pump</i>	<i>Capacitance</i>			
		<i>Single-phase</i>	<i>(230 V or 240 V)</i>	<i>(110 V)</i>		
		PLURIJETm 3/80	12.5 µF 450 VL	30 µF 250 VL		
		PLURIJETm 4/80	14 µF 450 VL	30 µF 250 VL		
		PLURIJETm 3/100				
		PLURIJETm 4/100	20 µF 450 VL	60 µF 300 VL		
8	ELECTRIC MOTOR	PLURIJETm: single-phase 230 V - 50 Hz with thermal overload protector built-in to the winding.				
		PLURIJET: three-phase 230/400 V - 50 Hz.				
		<p>⇒ Pumps fitted with the three-phase motor option offer IE2 (IEC 60034-30) class high performance</p> <ul style="list-style-type: none"> - Insulation: F class. - Protection: IP 44. 				

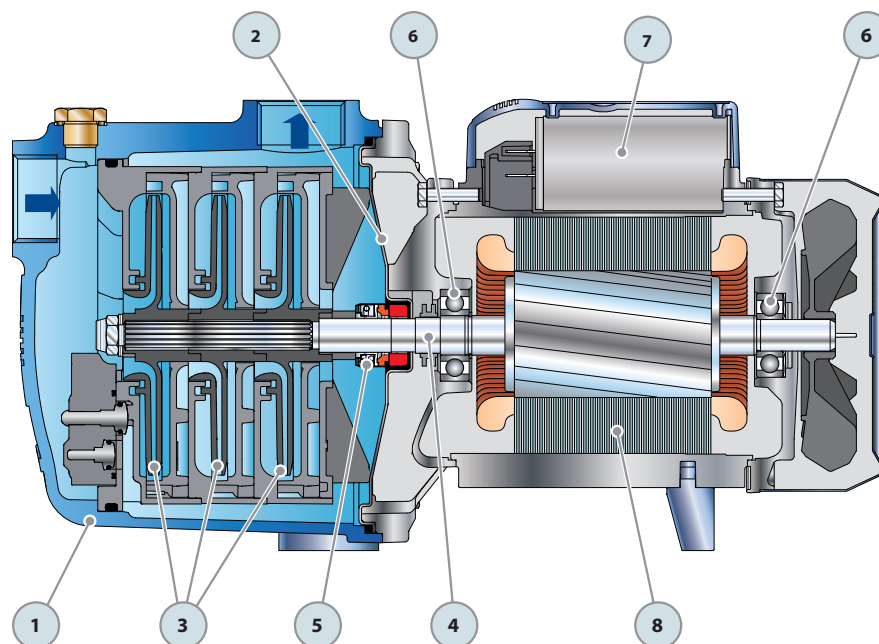

DIMENSIONS AND WEIGHT

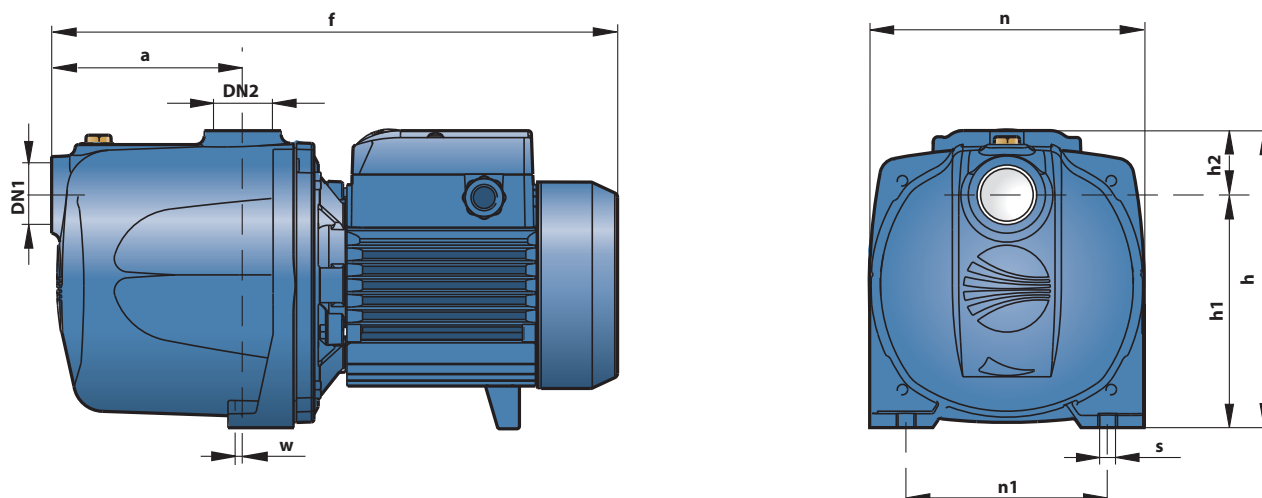

MODEL		PORTS		DIMENSIONS mm									kg	
Single-phase	Three-phase	DN1	DN2	a	f	h	h1	h2	n	n1	w	s	1~	3~
PLURIJETm 3/80	-	1"	1"	110	334	172	134	38	158	116	2	9	10.0	-
PLURIJETm 4/80	PLURIJET 4/80			135	357								11.3	10.7
PLURIJETm 3/100	PLURIJET 3/100			110	334	10.5		10.0						
PLURIJETm 4/100	PLURIJET 4/100			135	378	191		61					13.7	12.7

ABSORPTION

MODEL	VOLTAGE (single-phase)		
	230 V	240 V	110 V
Single-phase	230 V	240 V	110 V
PLURIJETm 3/80	3.4 A	3.3 A	6.8 A
PLURIJETm 4/80	4.3 A	4.2 A	8.6 A
PLURIJETm 3/100	4.1 A	4.0 A	8.2 A
PLURIJETm 4/100	6.0 A	5.8 A	12.0 A

MODEL	VOLTAGE (three-phase)					
	230 V	400 V	690 V	240 V	415 V	720 V
Three-phase	230 V	400 V	690 V	240 V	415 V	720 V
PLURIJET 4/80	3.4 A	2.0 A	1.1 A	3.3 A	1.9 A	1.1 A
PLURIJET 3/100	3.1 A	1.8 A	1.0 A	3.0 A	1.7 A	1.0 A
PLURIJET 4/100	4.5 A	2.6 A	1.5 A	4.3 A	2.5 A	1.4 A

PALLETIZATION

MODEL		GROUPAGE				CONTAINER			
Single-phase	Three-phase	n° pumps	H (mm)	kg		n° pumps	H (mm)	kg	
				1~	3~			1~	3~
PLURIJETm 3/80	-	98	1440	980	-	154	2180	1560	-
PLURIJETm 4/80	PLURIJET 4/80	98	1440	1130	1070	154	2180	1760	1670
PLURIJETm 3/100	PLURIJET 3/100	98	1440	1050	1000	154	2180	1640	1560
PLURIJETm 4/100	PLURIJET 4/100	98	1540	1360	1260	140	2140	1940	1800

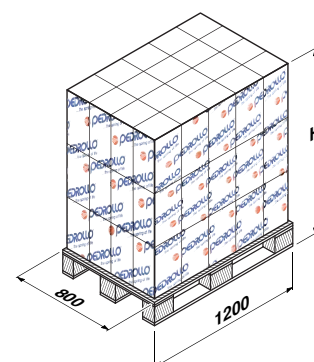

PLURIJET 90-130-200

Self-priming multi-stage pumps



PERFORMANCE RANGE

- Flow rate up to **200 l/min** (12 m³/h)
- Head up to **97 m**

APPLICATION LIMITS

- Manometric suction lift up to **9 m** (HS)
- Liquid temperature between **-10 °C** and **+40 °C**
- Ambient temperature up to **+40 °C**
- Max. working pressure **10 bar**
- Continuous service **S1**

CONSTRUCTION AND SAFETY STANDARDS

EN 60335-1
IEC 60335-1
CEI 61-150

EN 60034-1
IEC 60034-1
CEI 2-3



CERTIFICATIONS



INSTALLATION AND USE

Suitable for use with clean water even where air is present and with liquids that are not chemically aggressive towards the materials from which the pump is made.

The self-priming "PLURIJET" pumps are designed to pump water even in cases where air is present. As a result of their quietness, reliability and low energy consumption they are recommended for use in domestic and civil applications such as the pressurisation and distribution of water in combination with pressure sets, and in rain water recovery and irrigation systems, etc.

The pump should be installed in an enclosed environment, or at least sheltered from inclement weather.

PATENTS - TRADE MARKS - MODELS

- PLURIJET® is a registered trade mark
- Registered Community Design n° 342159-0007

OPTIONALS AVAILABLE ON REQUEST

- Other voltages or 60 Hz frequency
- IP55 class protection

GUARANTEE

1 year subject to terms and conditions

CHARACTERISTIC CURVES AND PERFORMANCE DATA

50 Hz n= 2900 1/min HS= 0 m

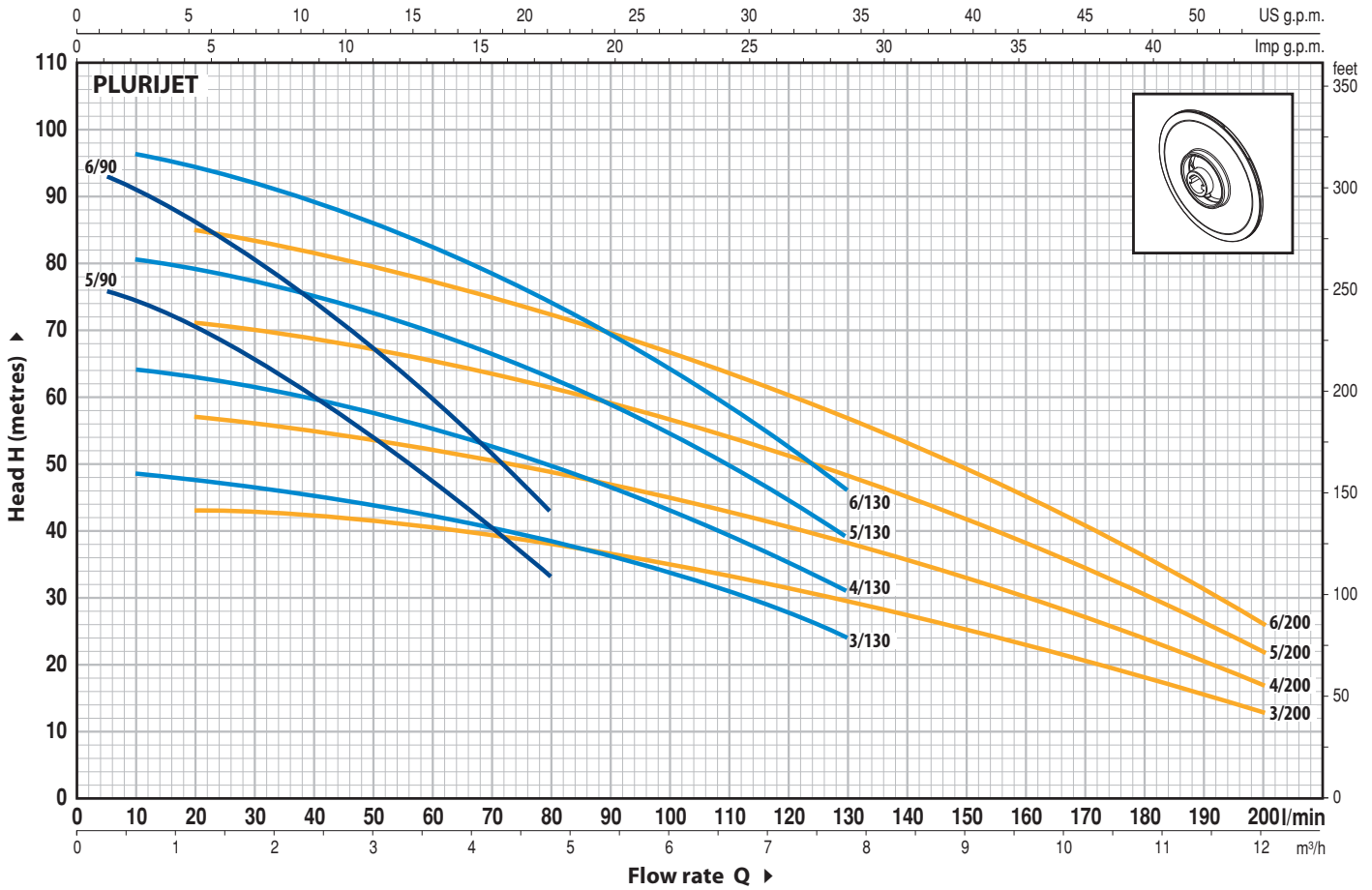

MODEL		POWER		Q	H metres												
Single-phase	Three-phase	kW	HP		m³/h	0	0.3	0.6	1.2	2.4	3.6	4.8	6.0	7.8	8.4	9.6	10.8
				l/min	0	5	10	20	40	60	80	100	130	140	160	180	200
PLURIJETm 5/90	PLURIJET 5/90	1.1	1.5	H metres	76	76	73.5	70	60.5	47	33						
PLURIJETm 6/90	PLURIJET 6/90	1.5	2		93	93	90.5	86	74.5	59.5	43						
PLURIJETm 3/130	PLURIJET 3/130	1.1	1.5		49	49	48.5	47.5	45	42.5	38.5	33.5	24				
PLURIJETm 4/130	PLURIJET 4/130	1.5	2		65	65	64	63	60	56	50	43	31				
-	PLURIJET 5/130	1.8	2.5		81	81	80.5	79	75	70	62.5	54	39				
-	PLURIJET 6/130	2.2	3		97	97	96.5	94.5	90	83	74.5	64	46				
PLURIJETm 3/200	PLURIJET 3/200	1.1	1.5		44	43.5	43.5	43	42	40.5	38	35	29	27.5	23	18	13
PLURIJETm 4/200	PLURIJET 4/200	1.5	2		58	57.5	57.5	57	55	52.5	49.5	45	38	35.5	30	24	17
-	PLURIJET 5/200	1.8	2.5		73	72	71.5	71	69	65.5	62	56.5	48	44.5	38	30	22
-	PLURIJET 6/200	2.2	3		87	86	85.5	85	82	78	73	67	57	53	45	36	26

Q = Flow rate H = Total manometric head HS = Suction height

Tolerance of characteristic curves in compliance with EN ISO 9906 App. A.

INSTALLATION EXAMPLE

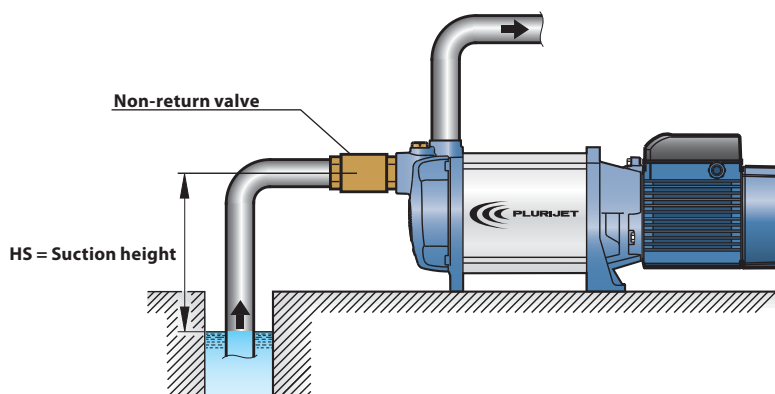

PLURIJET 90-130-200

POS.	COMPONENT	CONSTRUCTION CHARACTERISTICS				
1	PUMP BODY	Cast iron and stainless steel AISI 304, complete with threaded ports in compliance with ISO 228/1				
2	BODY BACKPLATE	Cast iron				
3	IMPELLERS	Noryl GFN2V				
4	DIFFUSERS	Stainless steel AISI 304, complete with anti-wear ring				
5	MOTOR SHAFT	Stainless steel EN 10088-3 - 1.4104				
6	MECHANICAL SEAL	Seal	Shaft	Materials		
		<i>Model</i>	<i>Diameter</i>	<i>Stationary ring</i>	<i>Rotational ring</i>	<i>Elastomer</i>
		FN-18	Ø 18 mm	Graphite	Ceramic	NBR
7	BEARINGS	6206 ZZ - C3 / 6204 ZZ				
8	CAPACITOR	Pump	Capacitance			
		<i>Single-phase</i>	<i>(230 V or 240 V)</i>	<i>(110 V)</i>		
		PLURIJETm 5/90				
		PLURIJETm 3/130	31.5 µF 450 VL	60 µF 250 VL		
		PLURIJETm 3/200				
		PLURIJETm 6/90				
PLURIJETm 4/130	45 µF 450 VL	80 µF 250 VL				
PLURIJETm 4/200						
9	ELECTRIC MOTOR	PLURIJETm: single-phase 230 V - 50 Hz with thermal overload protector built-in to the winding. PLURIJET: three-phase 230/400 V - 50 Hz. ⇒ Pumps fitted with the three-phase motor option offer IE2 (IEC 60034-30) class high performance – Insulation: F class. – Protection: IP 44.				

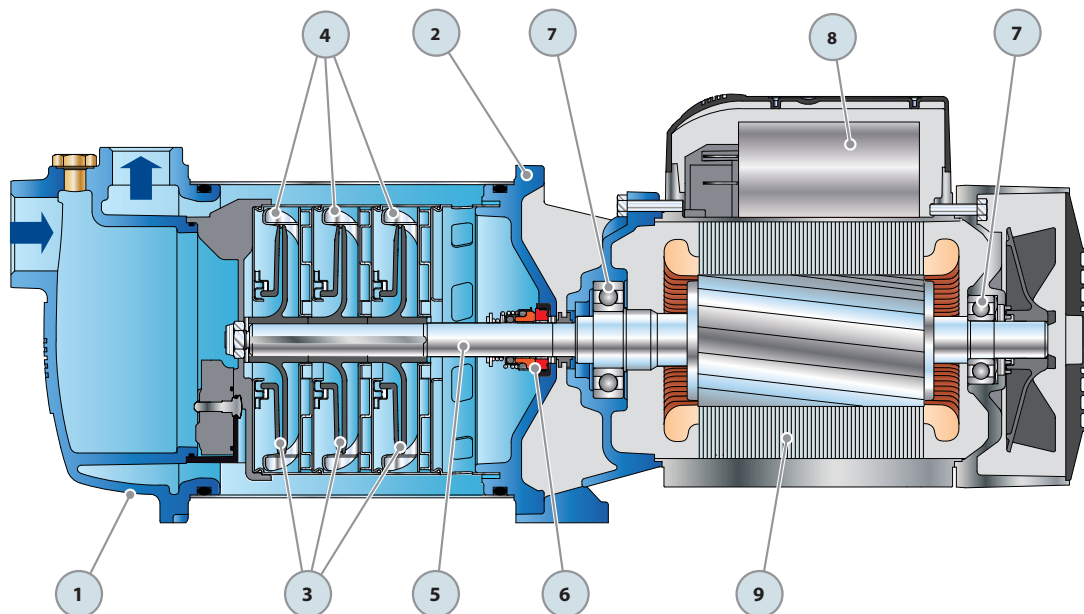

DIMENSIONS AND WEIGHT

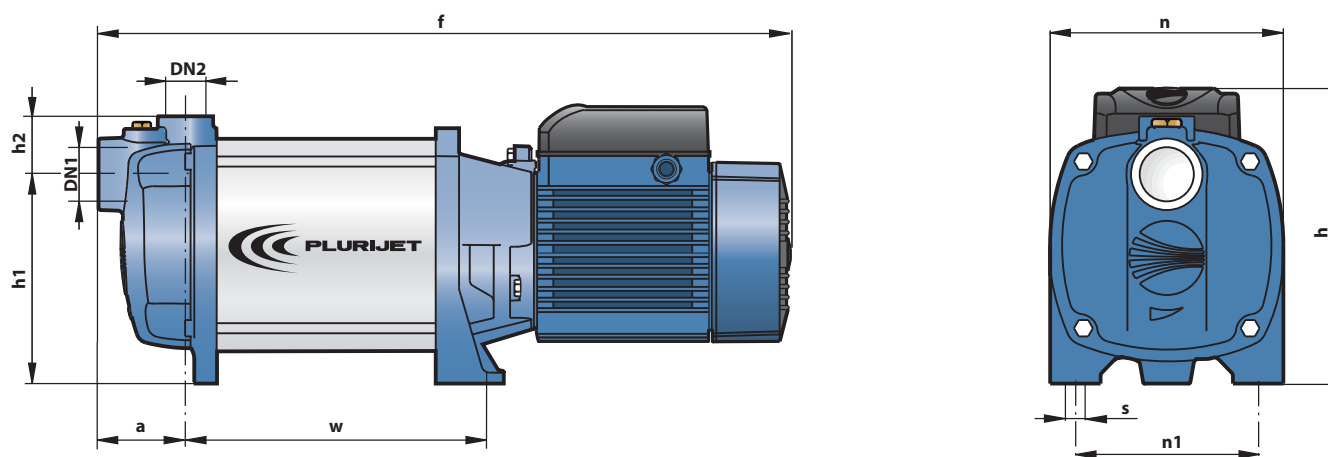

MODEL		PORTS		DIMENSIONS mm									kg			
Single-phase	Three-phase	DN1	DN2	a	f	h	h1	h2	n	n1	w	s	1~	3~		
PLURIJETm 5/90	PLURIJET 5/90	1 1/4"	1"	69	634	230	153	46	185	145	304	10	26.6	24.8		
PLURIJETm 6/90	PLURIJET 6/90				665						335				28.7	27.8
PLURIJETm 3/130	PLURIJET 3/130				571						241				24.8	22.9
PLURIJETm 4/130	PLURIJET 4/130				602						272				26.9	25.9
-	PLURIJET 5/130				634						304				-	27.9
-	PLURIJET 6/130				665						335				-	28.8
PLURIJETm 3/200	PLURIJET 3/200				571						241				24.8	22.9
PLURIJETm 4/200	PLURIJET 4/200				602						272				26.9	25.9
-	PLURIJET 5/200				634						304				-	27.9
-	PLURIJET 6/200				665						335				-	28.8

ABSORPTION

MODEL	VOLTAGE (single-phase)		
	230 V	240 V	110 V
PLURIJETm 5/90	8.5 A	8.2 A	17.0 A
PLURIJETm 6/90	10.5 A	10.0 A	21.0 A
PLURIJETm 3/130	8.5 A	8.2 A	17.0 A
PLURIJETm 4/130	10.5 A	10.0 A	21.0 A
PLURIJETm 3/200	8.5 A	8.2 A	17.0 A
PLURIJETm 4/200	10.5 A	10.0 A	21.0 A

MODEL	VOLTAGE (three-phase)					
	230 V	400 V	690 V	240 V	415 V	720 V
PLURIJET 5/90	5.7 A	3.3 A	1.9 A	5.5 A	3.2 A	1.8 A
PLURIJET 6/90	8.1 A	4.7 A	2.7 A	7.8 A	4.5 A	2.6 A
PLURIJET 3/130	5.7 A	3.3 A	1.9 A	5.5 A	3.2 A	1.8 A
PLURIJET 4/130	8.5 A	4.9 A	2.8 A	8.1 A	4.7 A	2.7 A
PLURIJET 5/130	8.7 A	5.0 A	2.9 A	8.3 A	4.8 A	2.8 A
PLURIJET 6/130	10.4 A	6.0 A	3.5 A	10.0 A	5.8 A	3.4 A
PLURIJET 3/200	5.7 A	3.3 A	1.9 A	5.5 A	3.2 A	1.8 A
PLURIJET 4/200	8.1 A	4.7 A	2.7 A	7.8 A	4.5 A	2.6 A
PLURIJET 5/200	8.7 A	5.0 A	2.9 A	8.3 A	4.8 A	2.8 A
PLURIJET 6/200	10.4 A	6.0 A	3.5 A	10.0 A	5.8 A	3.4 A

PALLETIZATION

MODEL		GROUPAGE / CONTAINER			
Single-phase	Three-phase	n° pumps	H (mm)	kg	
				1~	3~
PLURIJETm 5/90	PLURIJET 5/90	30	1430	820	760
PLURIJETm 6/90	PLURIJET 6/90	30	1430	880	850
PLURIJETm 3/130	PLURIJET 3/130	40	1430	1010	940
PLURIJETm 4/130	PLURIJET 4/130	40	1430	1100	1060
-	PLURIJET 5/130	30	1430	-	860
-	PLURIJET 6/130	30	1430	-	880
PLURIJETm 3/200	PLURIJET 3/200	40	1430	1010	940
PLURIJETm 4/200	PLURIJET 4/200	40	1430	1100	1060
-	PLURIJET 5/200	30	1430	-	860
-	PLURIJET 6/200	30	1430	-	880

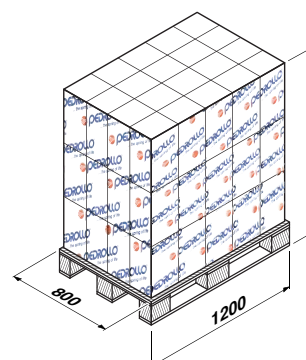

MULTISPEED

Self-priming pump with inverter



PERFORMANCE RANGE

The working pressure can be set at four different values: 1.5 / 2.5 / 3.0 / 3.3 bar.

Pressure selected	Flow rate available
3.3 bar	0 ÷ 45 l/min
3.0 bar	0 ÷ 50 l/min
2.5 bar	0 ÷ 60 l/min
1.5 bar	0 ÷ 75 l/min

APPLICATION LIMITS

- Manometric suction lift up to **9 m** (HS)
- Liquid temperature between **-10 °C** and **+40 °C**
- Ambient temperature up to **+40 °C**
- Max. working pressure **6 bar**
- Continuous service **S1**

CONSTRUCTION AND SAFETY STANDARDS

Complete with **1.5 m** long power cable

EN 60335-1
IEC 60335-1
CEI 61-150

EN 60034-1
IEC 60034-1
CEI 2-3



CERTIFICATIONS



AN30

INSTALLATION AND USE

Suitable for use with clean water even where air is present and with liquids that are not chemically aggressive towards the materials from which the pump is made.

Under normal working conditions a pump may be required to supply water at various flow rates which also results in variations in the pressure. The MULTISPEED pump automatically varies the rotational speed of the motor according to the required flow rate thereby giving constant pressure and low energy consumption. As a result, the annoying sudden change in pressure that normally occurs when extra taps are opened is eliminated and energy consumption may be reduced by up to 25%. Variable speed operation also reduces the level of noise and the vibration produced by the pump when compared with traditional solutions. The unit also incorporates built in protection that stops the pump if its water supply runs dry.

The pump should be installed in an enclosed environment, or at least sheltered from inclement weather.

PATENTS - TRADE MARKS - MODELS

- MULTISPEED® is a registered trade mark.

GUARANTEE

1 year subject to terms and conditions

CHARACTERISTIC CURVES AND PERFORMANCE DATA

50/60 Hz HS= 0 m

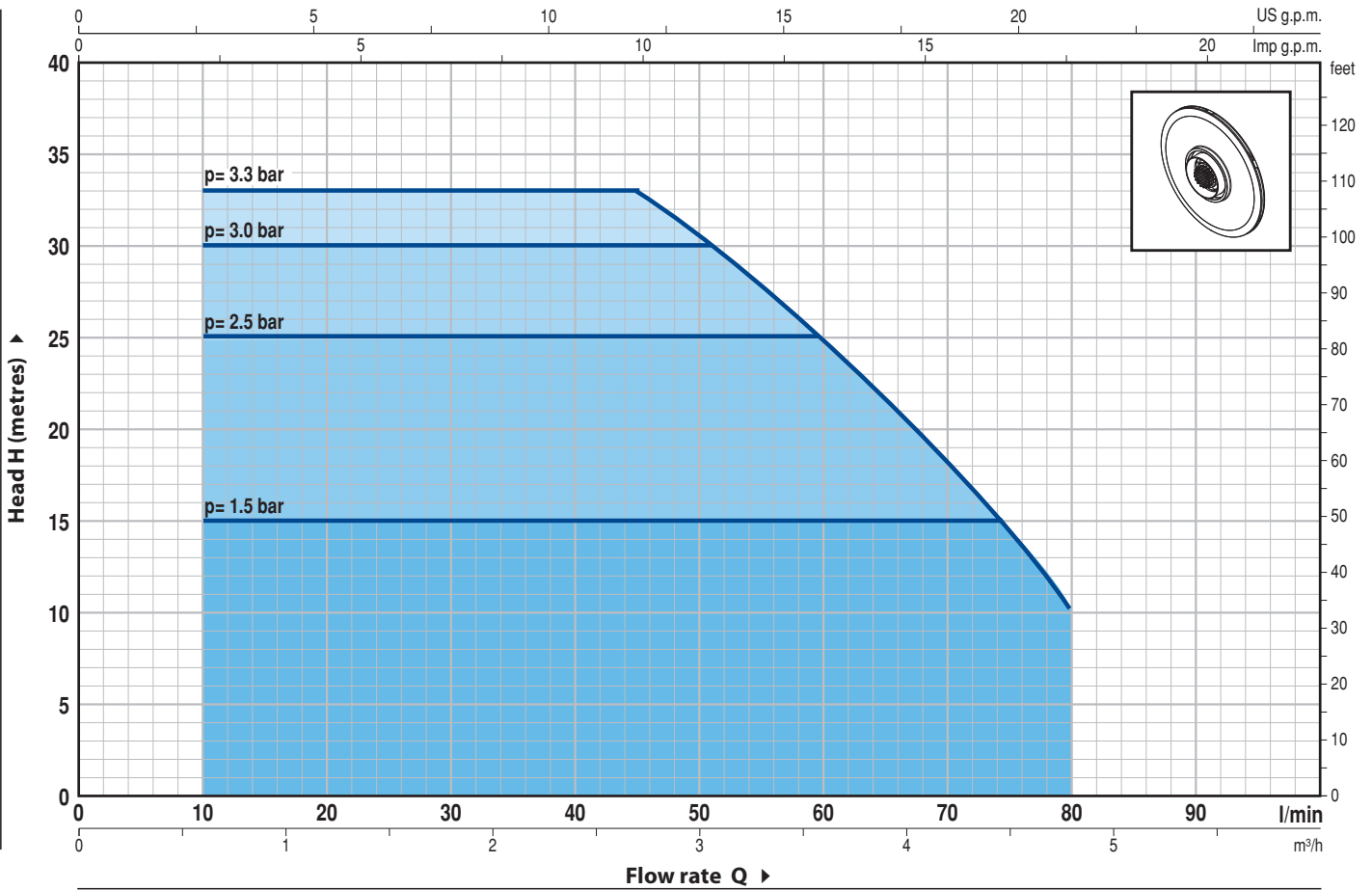

MODEL	POWER		p	Q	Flow rate							
	kW	HP			Setting Pressure	m³/h	0	0.6	2.7	3.0	3.6	4.5
Single-phase					0	10	45	50	60	75	80	
MULTISPEED 3/80	0.45	0.60	1.5 bar	H metres	15	15	15	15	15	15	15	10
			2.5 bar		25	25	25	25	25	15	10	
			3.0 bar		30	30	30	30	25	15	10	
			3.3 bar		33	33	33	30	25	15	10	

Q = Flow rate H = Total manometric head HS = Suction height

Tolerance of characteristic curves in compliance with EN ISO 9906 App. A.

INSTALLATION EXAMPLE

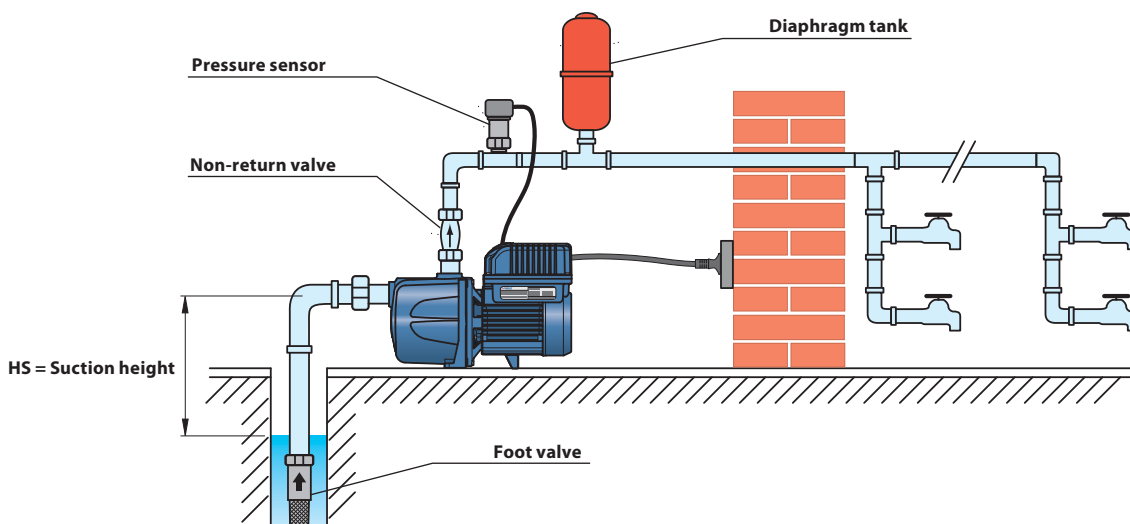

MULTISPEED

POS.	COMPONENT	CONSTRUCTION CHARACTERISTICS				
1	PUMP BODY	Cast iron, complete with threaded ports in compliance with ISO 228/1				
2	BODY BACKPLATE	Stainless steel AISI 304				
3	IMPELLERS	Noryl GFN2V				
4	MOTOR SHAFT	Stainless steel EN 10088-3 - 1.4104				
5	MECHANICAL SEAL	<i>Seal</i>	<i>Shaft</i>	<i>Materials</i>		
		<i>Model</i>	<i>Diameter</i>	<i>Stationary ring</i>	<i>Rotational ring</i>	<i>Elastomer</i>
		AR-13	Ø 13 mm	Ceramic	Graphite	NBR
6	BEARINGS	6202 ZZ - C3 / 6201 ZZ				
7	INVERTER					
8	ELECTRIC MOTOR	MULTISPEED: single-phase 230 V - 50/60 Hz. – Insulation: F class. – Protection: IP 44.				
9	PRESSURE SENSOR	Complete with 1.5 metre long cable				
10	POWER CABLE	1.5 metre long "H07 RN-F" cable with Schuko plug				

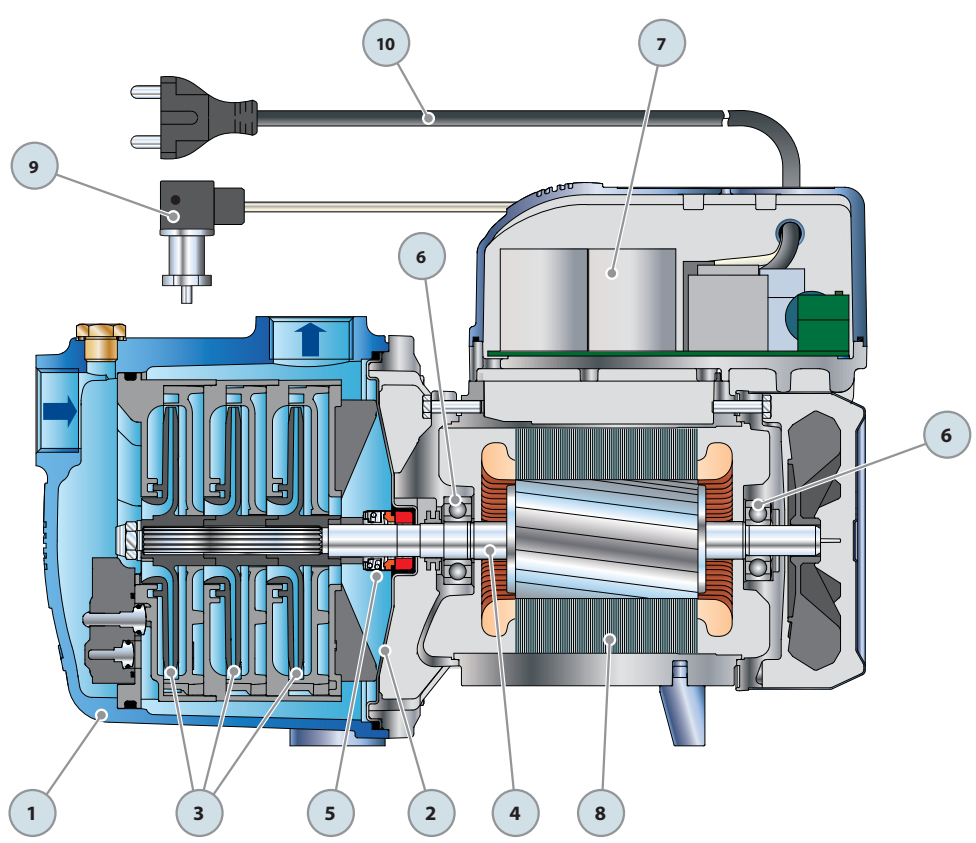

DIMENSIONS AND WEIGHT

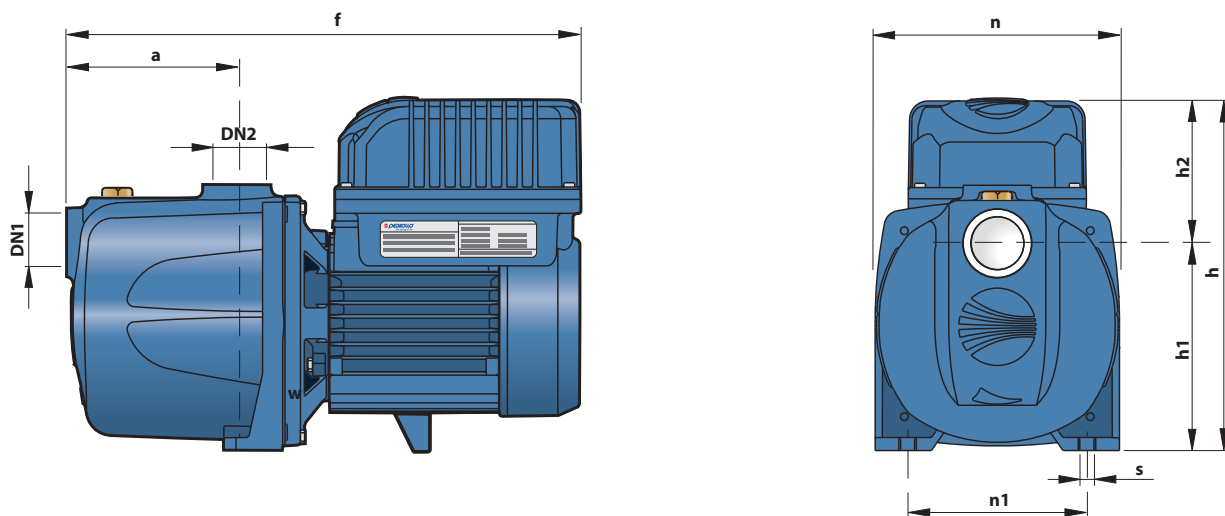

MODEL	PORTS		DIMENSIONS mm									kg	
	DN1	DN2	a	f	h	h1	h2	n	n1	w	s		
Single-phase													1~
MULTISPEED 3/80	1"	1"	110	339	225	134	91	158	116	2	9		12.3

ABSORPTION

MODEL	VOLTAGE (single-phase)
Single-phase	230 V
MULTISPEED 3/80	7.0 A

PALLETIZATION

MODEL	GROUPAGE / CONTAINER		
	n° pumps	H (mm)	kg
Single-phase			1~
MULTISPEED 3/80	48	1180	610

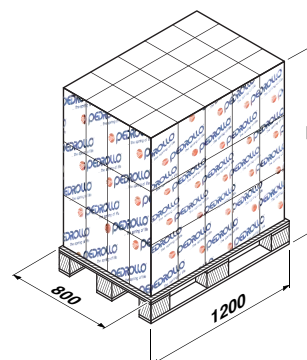



PERFORMANCE RANGE

- Flow rate up to **50 l/min** (3 m³/h)
- Head up to **51 m**

APPLICATION LIMITS

- Manometric suction lift up to **9 m** (HS)
- Liquid temperature between **-10 °C** and **+90 °C**
- Temperature of diesel up to **+55 °C**
- Ambient temperature up to **+40 °C**
- Max. working pressure **6 bar**
- Continuous service **S1**

CONSTRUCTION AND SAFETY STANDARDS

EN 60335-1
IEC 60335-1
CEI 61-150

EN 60034-1
IEC 60034-1
CEI 2-3



CERTIFICATIONS



INSTALLATION AND USE

Suitable for use with diesel, clean water that does not contain abrasive particles and liquids that are not chemically aggressive towards the materials from which the pump is made.

As a specific result of the pump's operating principle they are suitable for use in all situations where a compact self-priming pump is required or where the fluid supply is limited, irregular or contains air.

The pump should be installed in an enclosed environment, or at least sheltered from inclement weather.

PATENTS - TRADE MARKS - MODELS

- Motor bracket: patent n° IT1243605
- CK 80/90 Registered Community Design n° 342159-0008

OPTIONALS AVAILABLE ON REQUEST

- **CK-INT** pump with switch and power cable complete with Schuko plug
- **CKm 50-BP/NZ** pump with aluminium trigger dispensing nozzle and 4 metre long spiral reinforced hose.
- Special mechanical seal
- Other voltages or 60 Hz frequency
- IP 55 class protection

GUARANTEE

1 year subject to terms and conditions

CHARACTERISTIC CURVES AND PERFORMANCE DATA

50 Hz n= 2900 1/min HS= 0 m

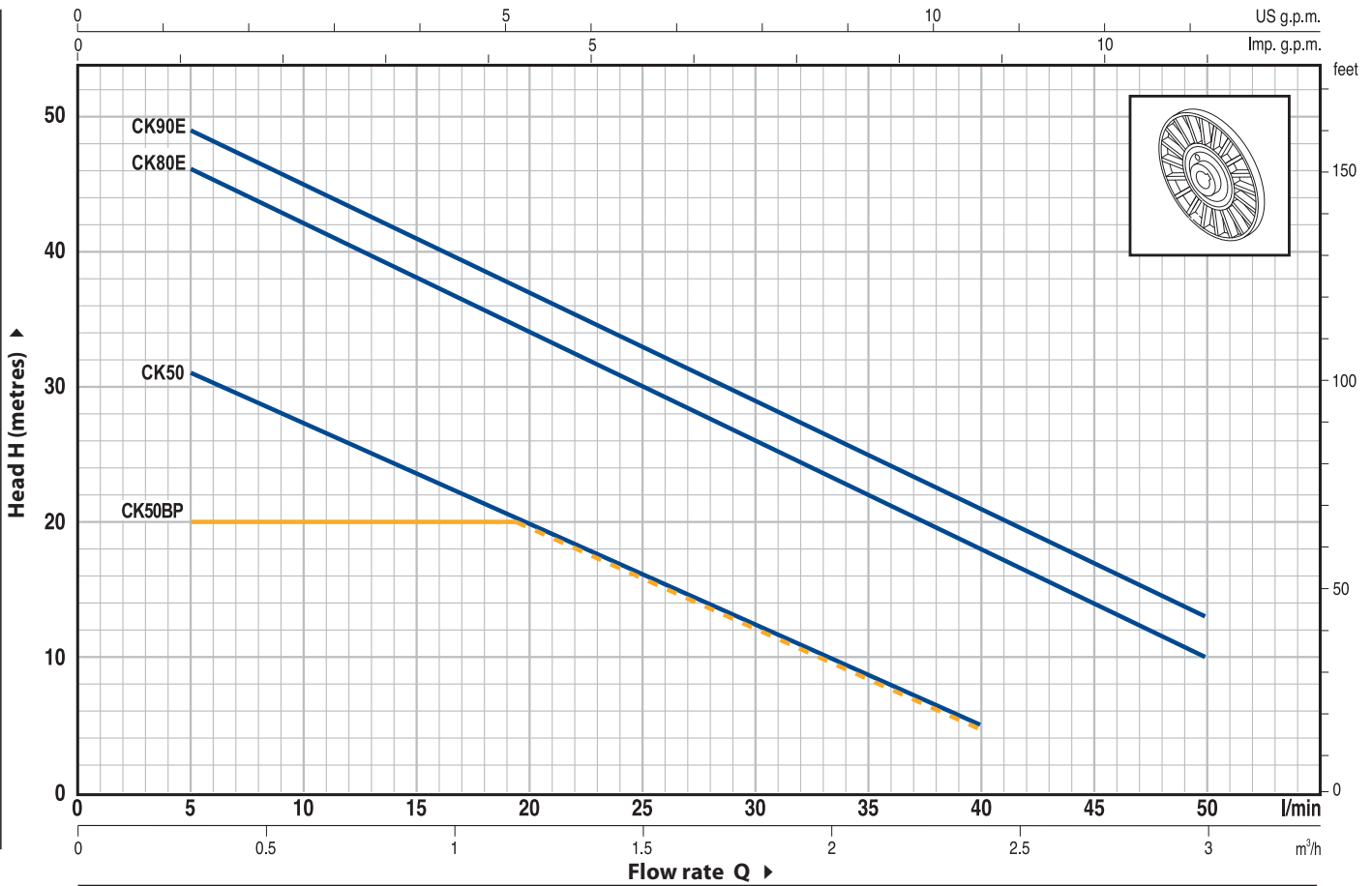

MODEL		POWER		Q	Flow rate												
Single-phase	Three-phase	kW	HP		m³/h	0	0.3	0.6	0.9	1.2	1.5	1.8	2.1	2.4	3.0		
				l/min	0	5	10	15	20	25	30	35	40	50			
CKm 50	CK 50	0.37	0.50	H metres	35	31	27	24	20	16	13	9	5				
CKm 50-BP	CK 50-BP	0.25	0.33		20	20	20	20	20	16.5	13	9	5				
CKm 80E	CK 80E	0.55	0.75		48	46	42	38	34	30	26	22	18	10			
CKm 90E	CK 90E	0.75	1		51	49	45	41	37	33	29	25	21	13			

Q = Flow rate H = Total manometric head HS = Suction height

Tolerance of characteristic curves in compliance with EN ISO 9906 App. A.

CK 50-BP = pump with integral by-pass

INSTALLATION EXAMPLE

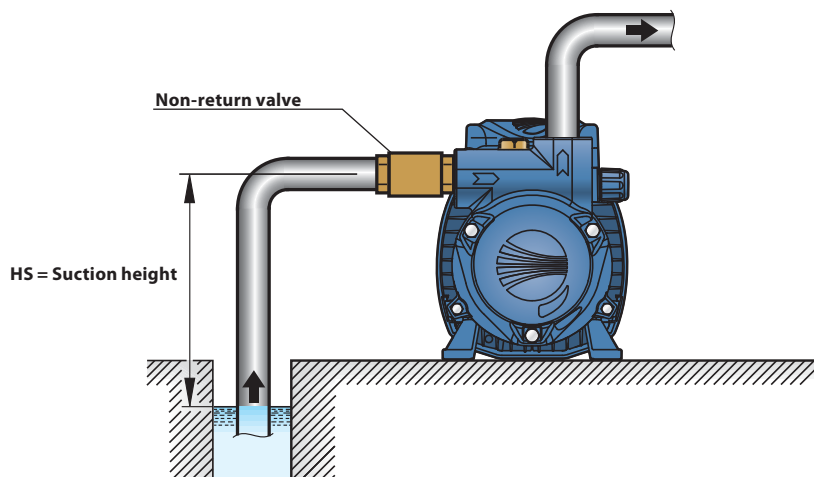

POS.	COMPONENT	CONSTRUCTION CHARACTERISTICS				
1	PUMP BODY	Cast iron, complete with threaded ports in compliance with ISO 228/1				
2	MOTOR BRACKET	Aluminium with brass insert (patented), reduces the risk of impeller seizure				
3	IMPELLER	Brass, star type with open radial vanes				
4	MOTOR SHAFT	Stainless steel EN 10088-3 - 1.4104				
5	MECHANICAL SEAL	Seal	Shaft	Materials		
		<i>Model</i>	<i>Diameter</i>	<i>Stationary ring</i>	<i>Rotational ring</i>	<i>Elastomer</i>
		AR-12V	Ø 12 mm	Ceramic	Graphite	Viton
6	BEARINGS	Pump	Model			
		CK 50	6201 ZZ / 6201 ZZ			
		CK 50-BP	6201 ZZ / 6201 ZZ			
		CK 80	6203 ZZ / 6203 ZZ			
		CK 90	6203 ZZ / 6203 ZZ			
7	CAPACITOR	Pump	Capacitance			
		<i>Single-phase</i>	<i>(230 V or 240 V)</i>	<i>(110 V)</i>		
		CKm 50	12.5 µF 450 VL	30 µF 250 VL		
		CKm 50-BP	12.5 µF 450 VL	30 µF 250 VL		
		CKm 80E	16 µF 450 VL	60 µF 300 VL		
		CKm 90E	20 µF 450 VL	60 µF 300 VL		

- 8 ELECTRIC MOTOR
- CKm:** single-phase 230 V - 50 Hz with thermal overload protector built-in to the winding.
CK: three-phase 230/400 V - 50 Hz.
- ➔ **Pumps fitted with the three-phase motor option offer IE2 (IEC 60034-30) class high performance**
- Insulation: F class.
 - Protection: IP 44.

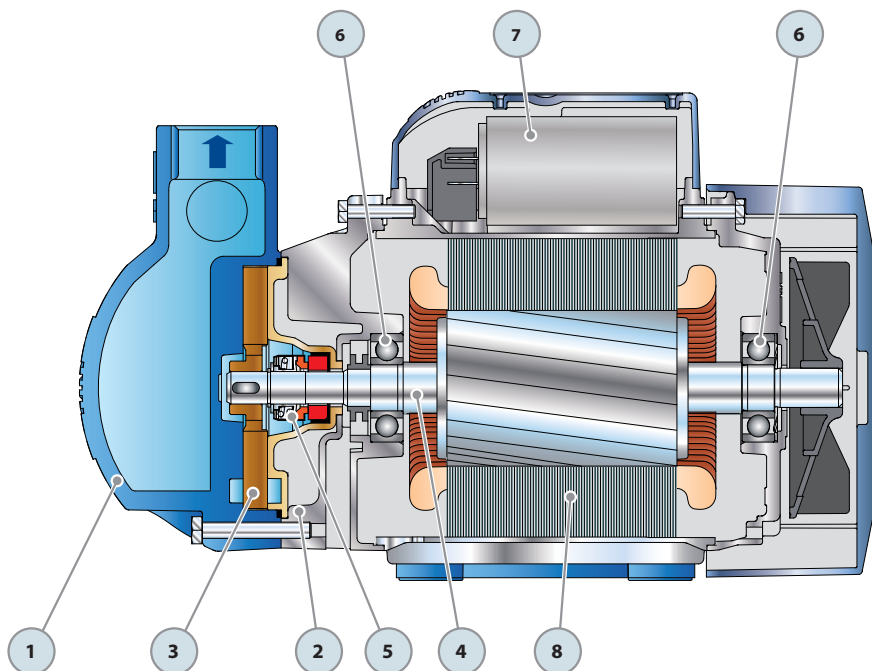

DIMENSIONS AND WEIGHT

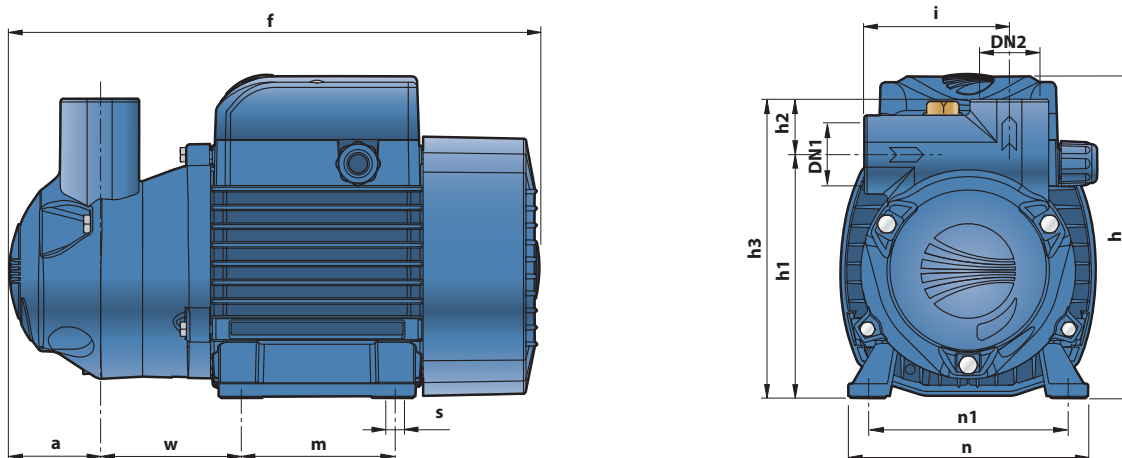

MODEL		PORTS		DIMENSIONS mm												kg	
Single-phase	Three-phase	DN1	DN2	a	f	h	h1	h2	h3	i	m	n	n1	w	s	1~	3~
CKm 50	CK 50	3/4"	3/4"	41	260	159	128	25	153	75	80	120	100	69	7	7.4	6.8
CKm 50-BP	CK 50-BP			44	263												
CKm 80E	CK 80E	1"	1"	50	296	180	136	31	167	81	90	140	112	77		10.8	9.9
CKm 90E	CK 90E			10.9	10.0												

ABSORPTION

MODEL	VOLTAGE (single-phase)		
Single-phase	230 V	240 V	110 V
CKm 50	3.0 A	2.9 A	6.2 A
CKm 50-BP	3.0 A	2.9 A	6.2 A
CKm 80E	5.0 A	4.8 A	9.8 A
CKm 90E	4.8 A	4.4 A	9.4 A

MODEL	VOLTAGE (three-phase)					
Three-phase	230 V	400 V	690 V	240 V	415 V	720 V
CK 50	2.1 A	1.2 A	0.7 A	2.0 A	1.2 A	0.7 A
CK 50-BP	2.1 A	1.2 A	0.7 A	2.0 A	1.2 A	0.7 A
CK 80E	3.5 A	2.0 A	1.2 A	3.4 A	2.0 A	1.2 A
CK 90E	3.5 A	2.0 A	1.2 A	3.4 A	2.0 A	1.2 A

PALLETIZATION

MODEL		GROUPAGE				CONTAINER			
Single-phase	Three-phase	n° pumps	H (mm)	kg		n° pumps	H (mm)	kg	
				1~	3~			1~	3~
CKm 50	CK 50	120	1280	910	840	180	1850	1350	1240
CKm 50-BP	CK 50-BP	120	1280	910	840	180	1850	1350	1240
CKm 80E	CK 80E	102	1370	1120	1030	136	1780	1490	1370
CKm 90E	CK 90E	102	1370	1130	1040	136	1780	1500	1380

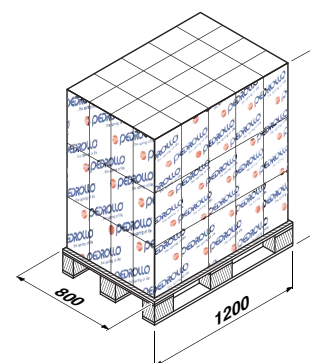

Self-priming liquid ring pumps

with double anti-seize inserts



PERFORMANCE RANGE

- Flow rate up to **50 l/min** (3 m³/h)
- Head up to **51 m**

APPLICATION LIMITS

- Manometric suction lift up to **9 m** (HS)
- Liquid temperature between **-10 °C** and **+90 °C**
- Temperature of diesel up to **+55 °C**
- Ambient temperature up to **+40 °C**
- Max. working pressure **6 bar**
- Continuous service **S1**

CONSTRUCTION AND SAFETY STANDARDS

EN 60335-1
IEC 60335-1
CEI 61-150

EN 60034-1
IEC 60034-1
CEI 2-3



CERTIFICATIONS



INSTALLATION AND USE

Suitable for use with clean water or liquids that do not contain abrasive particles and liquids that are not chemically aggressive towards the materials from which the pump is made.

As a specific result of the pump's operating principle they are suitable for use in all situations where a compact self-priming pump is required or where the fluid supply is limited, irregular or contains air.

The pump should be installed in an enclosed environment, or at least sheltered from inclement weather.

PATENTS - TRADE MARKS - MODELS

- Motor bracket: patent n° IT1243605
- Registered Community Design n° 342159-0008

OPTIONALS AVAILABLE ON REQUEST

- Special mechanical seal
- Other voltages or 60 Hz frequency
- IP 55 class protection

GUARANTEE

1 year subject to terms and conditions

CHARACTERISTIC CURVES AND PERFORMANCE DATA

50 Hz n= 2900 1/min HS= 0 m

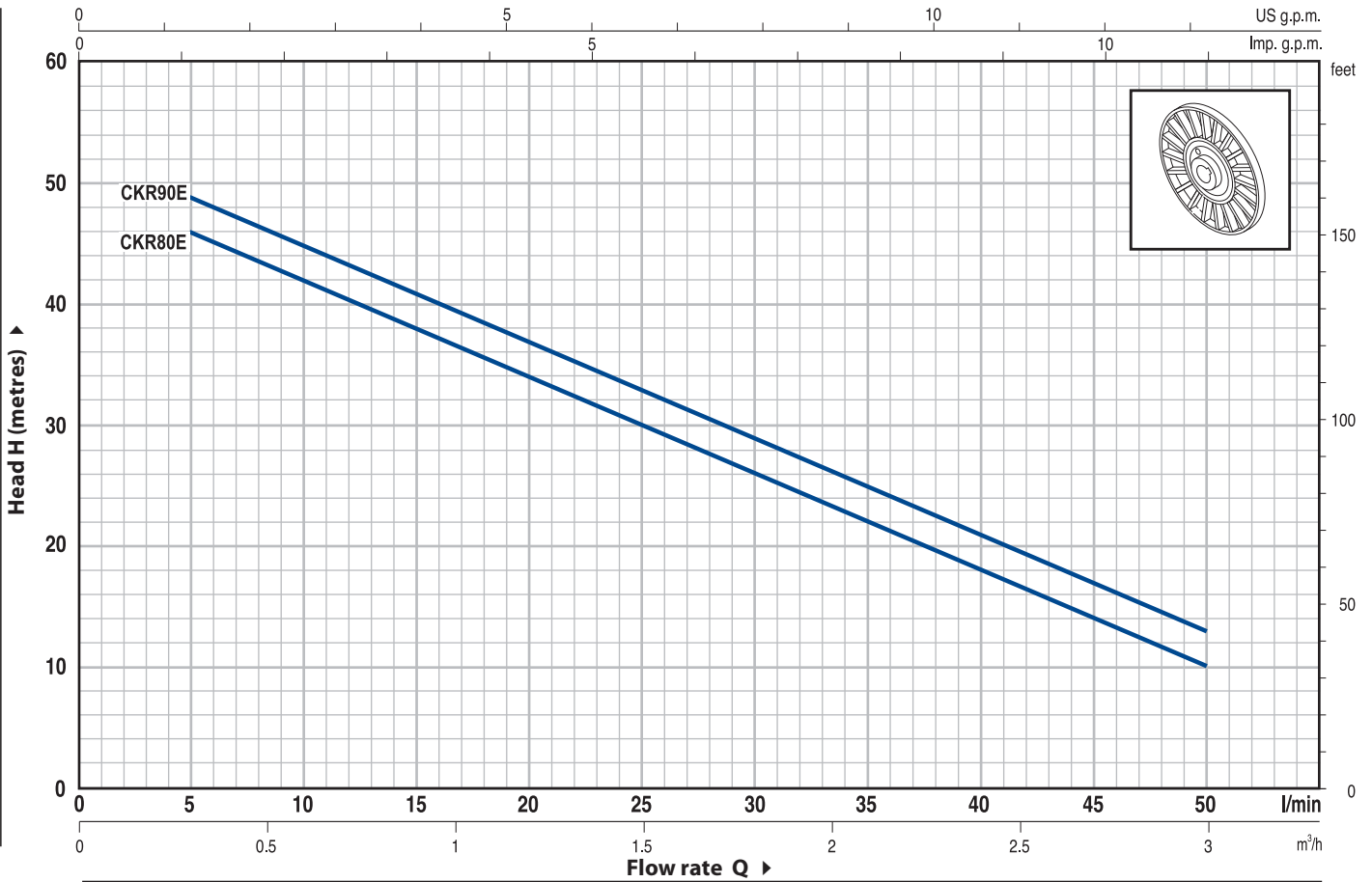

MODEL		POWER		Q	Flow rate												
Single-phase	Three-phase	kW	HP		m³/h	0	0.3	0.6	0.9	1.2	1.5	1.8	2.1	2.4	3.0		
CKRm 80E	CKR 80E	0.55	0.75	H metres	0	5	10	15	20	25	30	35	40	50			
CKRm 90E	CKR 90E	0.75	1		48	46	42	38	34	30	26	22	18	10			
					51	49	45	41	37	33	29	25	21	13			

Q = Flow rate H = Total manometric head HS = Suction height

Tolerance of characteristic curves in compliance with EN ISO 9906 App. A.

INSTALLATION EXAMPLE

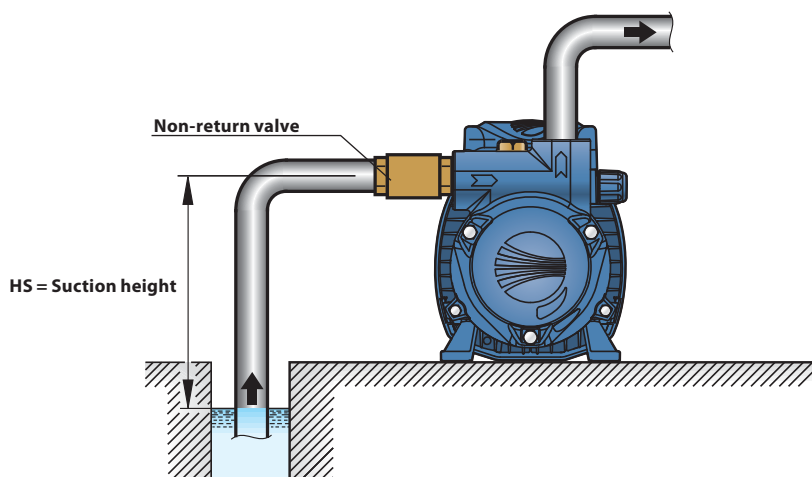

POS.	COMPONENT	CONSTRUCTION CHARACTERISTICS				
1	PUMP BODY	Cast iron, with stainless steel insert to prevent impeller seizure due to the formation of rust . The pump body is complete with threaded ports in compliance with ISO 228/1				
2	MOTOR BRACKET	Aluminium with brass insert (patented), reduces the risk of impeller seizure				
3	IMPELLER	Brass, star type with open radial vanes				
4	MOTOR SHAFT	Stainless steel EN 10088-3 - 1.4104				
5	MECHANICAL SEAL	<i>Seal</i>	<i>Shaft</i>	<i>Materials</i>		
		<i>Model</i>	<i>Diameter</i>	<i>Stationary ring</i>	<i>Rotational ring</i>	<i>Elastomer</i>
		AR-12V	Ø 12 mm	Ceramic	Graphite	Viton
6	BEARINGS	6203 ZZ / 6203 ZZ				
7	CAPACITOR	<i>Pump</i>	<i>Capacitance</i>			
		<i>Single-phase</i>	<i>(230 V or 240 V)</i>	<i>(110 V)</i>		
		CKRm 80E	16 µF 450 VL	60 µF 300 VL		
		CKRm 90E	20 µF 450 VL	60 µF 300 VL		
8	ELECTRIC MOTOR	CKRm: single-phase 230 V - 50 Hz with thermal overload protector built-in to the winding. CKR: three-phase 230/400 V - 50 Hz. ⇒ Pumps fitted with the three-phase motor option offer IE2 (IEC 60034-30) class high performance – Insulation: F class. – Protection: IP 44.				

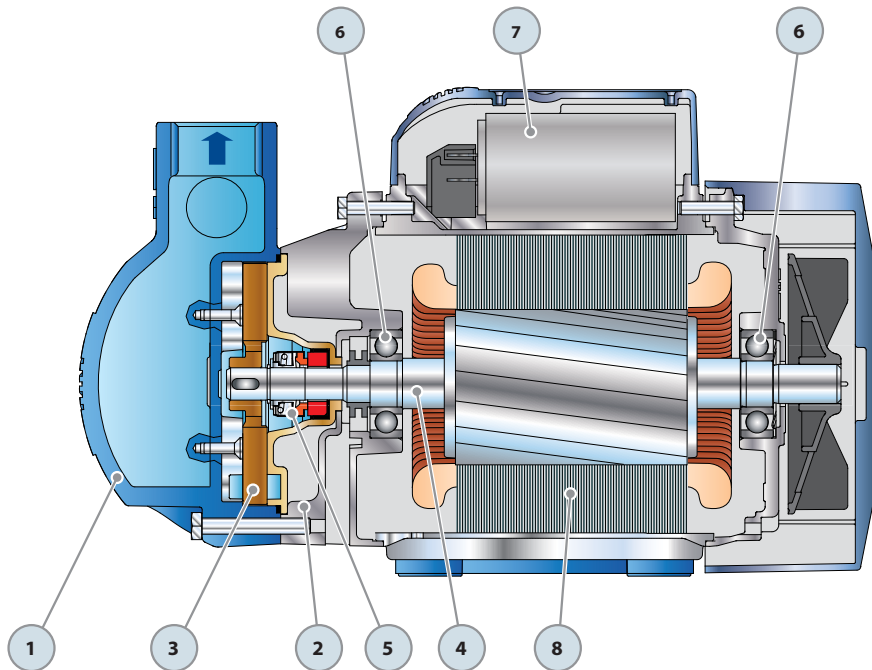

DIMENSIONS AND WEIGHT

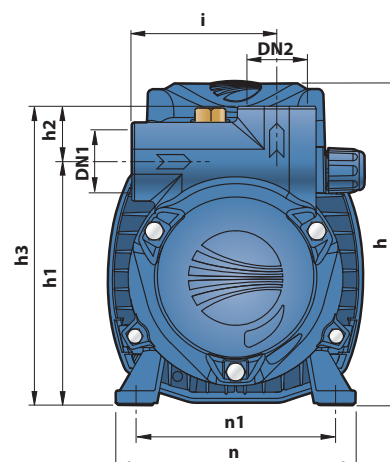
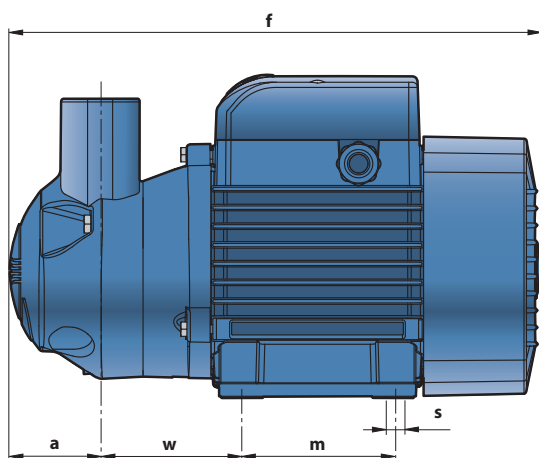

MODEL		PORTS		DIMENSIONS mm												kg	
Single-phase	Three-phase	DN1	DN2	a	f	h	h1	h2	h3	i	m	n	n1	w	s	1~	3~
CKRm 80E	CKR 80E	1"	1"	50	296	180	136	31	167	81	90	140	112	77	7	10.8	9.9
CKRm 90E	CKR 90E			10.9	10.0												

ABSORPTION

MODEL	VOLTAGE (single-phase)		
	230 V	240 V	110 V
Single-phase	230 V	240 V	110 V
CKRm 80E	5.0 A	4.8 A	9.8 A
CKRm 90E	4.8 A	4.4 A	9.4 A

MODEL	VOLTAGE (three-phase)					
	230 V	400 V	690 V	240 V	415 V	720 V
Three-phase	230 V	400 V	690 V	240 V	415 V	720 V
CKR 80E	3.5 A	2.0 A	1.2 A	3.4 A	2.0 A	1.2 A
CKR 90E	3.5 A	2.0 A	1.2 A	3.4 A	2.0 A	1.2 A

PALLETIZATION

MODEL		GROUPAGE				CONTAINER			
Single-phase	Three-phase	n° pumps	H (mm)	kg		n° pumps	H (mm)	kg	
				1~	3~			1~	3~
CKRm 80E	CKR 80E	102	1370	1120	1030	136	1780	1490	1370
CKRm 90E	CKR 90E	102	1370	1130	1040	136	1780	1500	1380

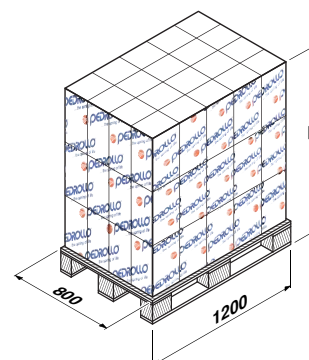

PK-PQ /Bz

Pumps with peripheral impellers and bronze pump bodies



PERFORMANCE RANGE

- Flow rate up to **70 l/min** (4.2 m³/h)
- Head up to **90 m**

APPLICATION LIMITS

- Manometric suction lift up to **8 m**
- Liquid temperature between **-10 °C** and **+90 °C**
- Ambient temperature up to **+40 °C**
- Max. working pressure **10 bar**
- Continuous service **S1**

CONSTRUCTION AND SAFETY STANDARDS

EN 60034-1
IEC 60034-1
CEI 2-3



CERTIFICATIONS



INSTALLATION AND USE

Suitable for use with clean water that does not contain abrasive particles and liquids that are not chemically aggressive towards the materials from which the pump is made.

The design solution of these pumps guarantees against the formation of rust and oxidation. As a result of their compact design and characteristic curves they are suitable for use in industrial applications such as cooling and conditioning, etc.

The pump should be installed in an enclosed environment, or at least sheltered from inclement weather.

PATENTS - TRADE MARKS - MODELS

- Motor bracket: patent n° IT1243605

OPTIONALS AVAILABLE ON REQUEST

- Special mechanical seal
- Other voltages or 60 Hz frequency
- IP 55 class protection

GUARANTEE

1 year subject to terms and conditions

CHARACTERISTIC CURVES AND PERFORMANCE DATA

50 Hz n= 2900 1/min HS= 0 m

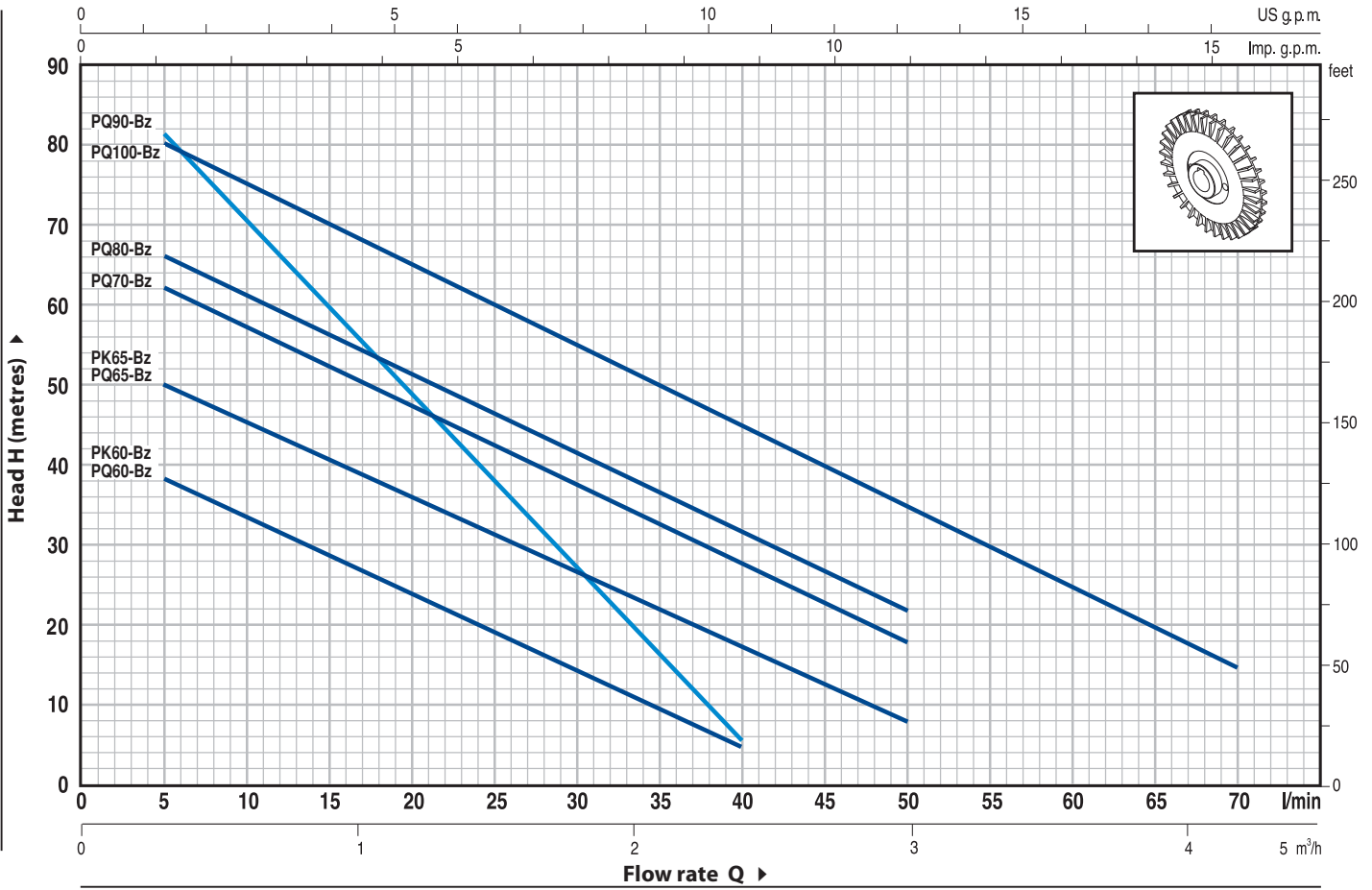

MODEL		POWER		Q	H metres															
Single-phase	Three-phase	kW	HP		0	0.3	0.6	0.9	1.2	1.5	1.8	2.1	2.4	3.0	3.6	4.2				
				l/min	0	5	10	15	20	25	30	35	40	50	60	70				
PKm 60-Bz	PK 60-Bz	0.37	0.50	H metres	40	38	33.5	29	24	19.5	15	10	5							
PQm 60-Bz	PQ 60-Bz				55	50	45.5	40.5	36	31	27	22	17	8						
PKm 65-Bz	PK 65-Bz	0.50	0.70		65	62	57	52	47	42	37	32	27	18						
PQm 65-Bz	PQ 65-Bz				70	66	61	56	51	46	41	36.5	31	22						
PQm 70-Bz	PQ 70-Bz	0.60	0.85		90	82	71	60	49	38	27	17	5							
PQm 80-Bz	PQ 80-Bz	0.75	1		85	80	75	70	65	60	55	50	45	35	25	15				
PQm 90-Bz	PQ 90-Bz	0.75	1																	
PQm 100-Bz	PQ 100-Bz	1.1	1.5																	

Q = Flow rate H = Total manometric head HS = Suction height

Tolerance of characteristic curves in compliance with EN ISO 9906 App. A.

POS.	COMPONENT	CONSTRUCTION CHARACTERISTICS				
1	PUMP BODY	Bronze, complete with threaded ports in compliance with ISO 228/1				
2	MOTOR BRACKET	Aluminium with brass insert (patented), reduces the risk of impeller seizure				
3	IMPELLER	Brass, with peripheral radial vanes				
4	MOTOR SHAFT	Stainless steel AISI 316				
5	MECHANICAL SEAL	<i>Seal</i>	<i>Shaft</i>	<i>Materials</i>		
		<i>Model</i>	<i>Diameter</i>	<i>Stationary ring</i>	<i>Rotational ring</i>	<i>Elastomer</i>
		FN-12V	Ø 12 mm	Graphite	Ceramic	Viton
6	BEARINGS	6201 ZZ - C3 / 6201 ZZ - C3				
7	CAPACITOR	<i>Pump</i>	<i>Capacitance</i>			
		<i>Single-phase</i>	<i>(230 V or 240 V)</i>	<i>(110 V)</i>		
		PKm 60-Bz	10 µF 450 VL	25 µF 250 VL		
		PKm 65-Bz	14 µF 450 VL	30 µF 250 VL		
8	ELECTRIC MOTOR	<p>PKm-Bz: single-phase 230 V - 50 Hz with thermal overload protector built-in to the winding.</p> <p>PK-Bz: three-phase 230/400 V - 50 Hz.</p> <p>⇒ Pumps fitted with the three-phase motor option offer IE2 (IEC 60034-30) class high performance</p> <ul style="list-style-type: none"> – Insulation: F class. – Protection: IP 44. 				

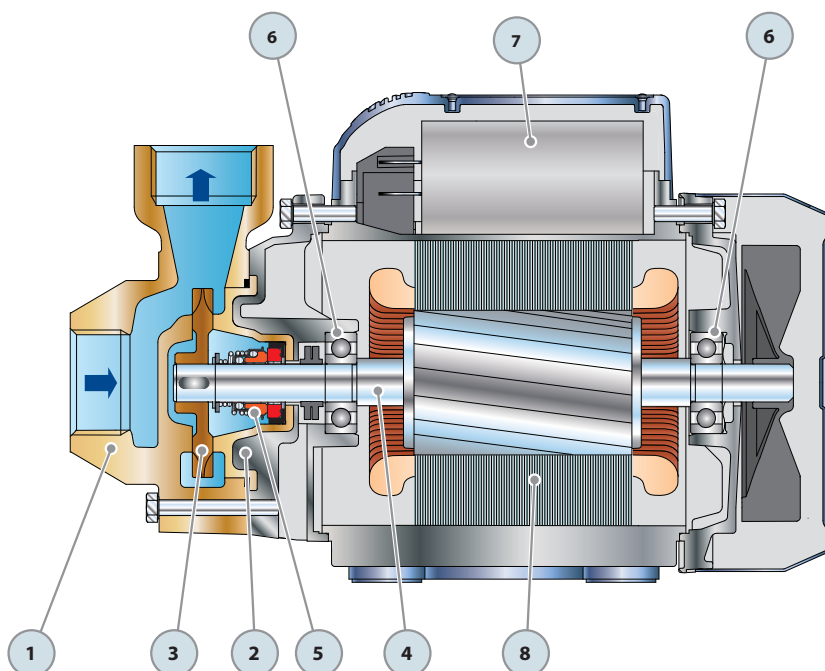

POS.	COMPONENT	CONSTRUCTION CHARACTERISTICS					
1	PUMP BODY	Bronze, complete with threaded ports in compliance with ISO 228/1					
2	MOTOR BRACKET	Aluminium with brass insert (patented), reduces the risk of impeller seizure					
3	IMPELLER	Brass, with peripheral radial vanes					
4	MOTOR SHAFT	Stainless steel AISI 316					
5	MECHANICAL SEAL	<i>Pump</i>	<i>Seal</i>	<i>Shaft</i>	<i>Materials</i>		
		<i>Model</i>	<i>Model</i>	<i>Diameter</i>	<i>Stationary ring</i>	<i>Rotational ring</i>	<i>Elastomer</i>
		PQ 60/65/70/80/90-Bz	FN-12V	Ø 12 mm	Graphite	Ceramic	Viton
		PQ 100-Bz	FN-14V	Ø 14 mm	Graphite	Ceramic	Viton
6	BEARINGS	<i>Pump</i>	<i>Model</i>				
		PQ 60/65-Bz	6201 ZZ - C3 / 6201 ZZ - C3				
		PQ 70/80/90-Bz	6203 ZZ - C3 / 6203 ZZ - C3				
		PQ 100-Bz	6204 ZZ - C3 / 6204 ZZ - C3				
7	CAPACITOR	<i>Pump</i>	<i>Capacitance</i>				
		<i>Single-phase</i>	<i>(230 V or 240 V)</i>		<i>(110 V)</i>		
		PQm 60-Bz	10 µF 450 VL	25 µF 250 VL			
		PQm 65-Bz	14 µF 450 VL	30 µF 250 VL			
		PQm 70-Bz	16 µF 450 VL	60 µF 300 VL			
		PQm 80-Bz	20 µF 450 VL	60 µF 300 VL			
		PQm 90-Bz	20 µF 450 VL	60 µF 300 VL			
		PQm 100-Bz	31.5 µF 450 VL	60 µF 250 VL			
8	ELECTRIC MOTOR	PQm-Bz: single-phase 230 V - 50 Hz with thermal overload protector built-in to the winding.					
		PQ-Bz: three-phase 230/400 V - 50 Hz.					
		⇒ Pumps fitted with the three-phase motor option offer IE2 (IEC 60034-30) class high performance – Insulation: F class. – Protection: IP 44.					

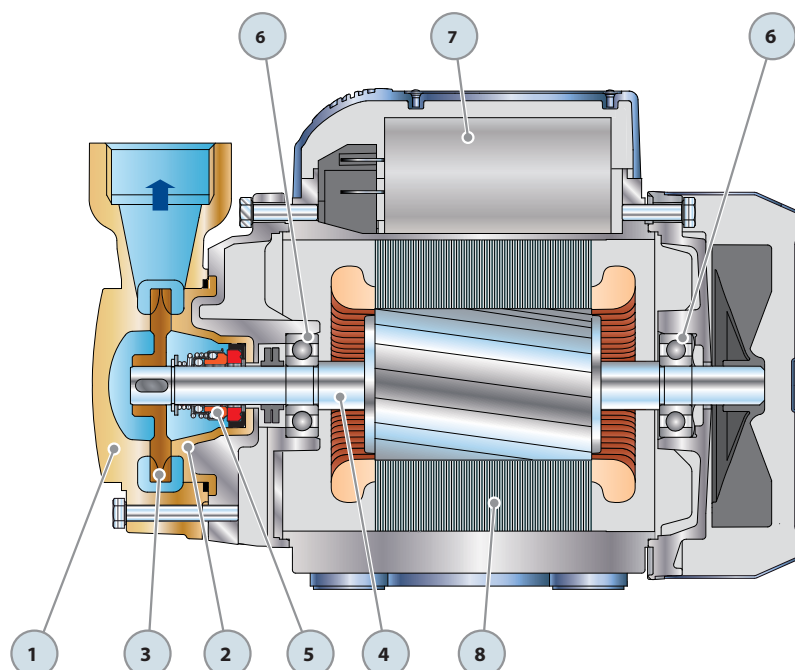

DIMENSIONS AND WEIGHT

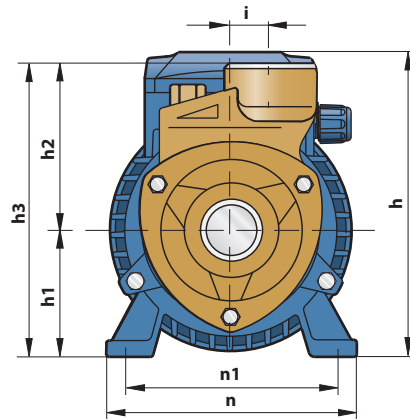
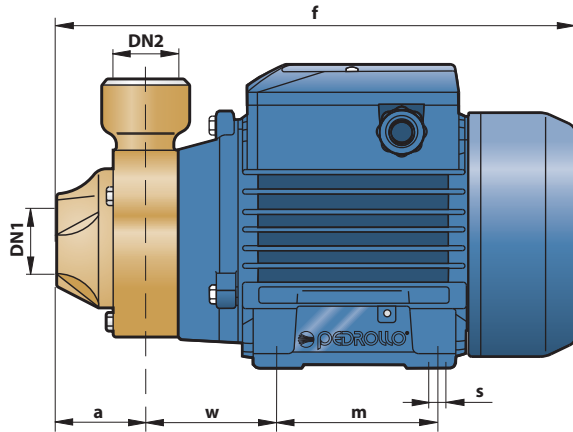

MODEL		PORTS		DIMENSIONS mm												kg	
Single-phase	Three-phase	DN1	DN2	a	f	h	h1	h2	h3	i	m	n	n1	w	s	1~	3~
PKm 60-Bz	PK 60-Bz	1"	1"	42	243	152	63	75	138	20	80	120	100	55	7	5.7	5.7
PKm 65-Bz	PK 65-Bz			48	250			80	143							7.2	6.8

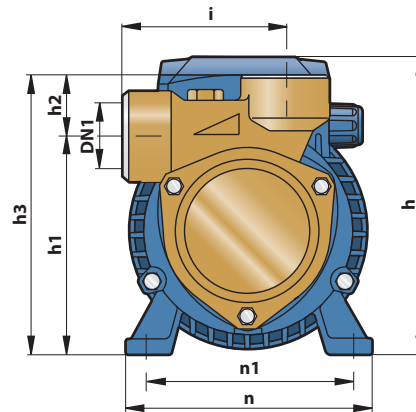
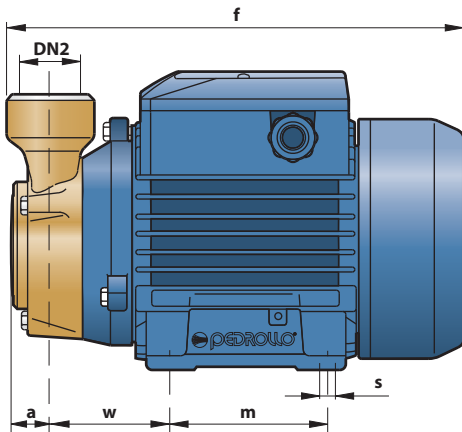

MODEL		PORTS		DIMENSIONS mm												kg						
Single-phase	Three-phase	DN1	DN2	a	f	h	h1	h2	h3	i	m	n	n1	w	s	1~	3~					
PQm 60-Bz	PQ 60-Bz	1"	1"	22	225	152	108	30	138	78	80	120	100	55	7	5.5	5.5					
PQm 65-Bz	PQ 65-Bz						113		143							7.0	6.5					
PQm 70-Bz	PQ 70-Bz						121		151							83	90	138	112	62	10.0	9.1
PQm 80-Bz	PQ 80-Bz						126		153							84	90	138	112	62	10.0	9.1
PQm 90-Bz	PQ 90-Bz	3/4"	3/4"	25	318	212	126	27	153	84	100	164	125	85	9	10.2	9.1					
PQm 100-Bz	PQ 100-Bz	1"	1"				140	30	170	89						100	164	125	85	9	15.3	13.4

ABSORPTION

MODEL	VOLTAGE (single-phase)		
	230 V	240 V	110 V
Single-phase	230 V	240 V	110 V
PKm 60-Bz	2.6 A	2.5 A	5.0 A
PKm 65-Bz	3.7 A	3.4 A	7.5 A

MODEL	VOLTAGE (single-phase)		
	230 V	240 V	110 V
Single-phase	230 V	240 V	110 V
PQm 60-Bz	2.6 A	2.5 A	5.0 A
PQm 65-Bz	3.7 A	3.4 A	7.5 A
PQm 70-Bz	5.2 A	4.8 A	10.8 A
PQm 80-Bz	5.2 A	4.8 A	10.8 A
PQm 90-Bz	5.6 A	5.1 A	11.5 A
PQm 100-Bz	9.0 A	8.2 A	18.0 A

MODEL	VOLTAGE (three-phase)					
	230 V	400 V	690 V	240 V	415 V	720 V
Three-phase	230 V	400 V	690 V	240 V	415 V	720 V
PK 60-Bz	1.9 A	1.15 A	0.6 A	1.9 A	1.1 A	0.6 A
PK 65-Bz	2.9 A	1.7 A	0.9 A	2.8 A	1.6 A	0.9 A

MODEL	VOLTAGE (three-phase)					
	230 V	400 V	690 V	240 V	415 V	720 V
Three-phase	230 V	400 V	690 V	240 V	415 V	720 V
PQ 60-Bz	1.9 A	1.15 A	0.6 A	1.9 A	1.1 A	0.6 A
PQ 65-Bz	2.9 A	1.7 A	0.9 A	2.8 A	1.6 A	0.9 A
PQ 70-Bz	3.8 A	2.2 A	1.3 A	3.3 A	1.9 A	1.1 A
PQ 80-Bz	3.8 A	2.2 A	1.3 A	3.3 A	1.9 A	1.1 A
PQ 90-Bz	4.2 A	2.4 A	1.4 A	3.8 A	2.2 A	1.3 A
PQ 100-Bz	6.3 A	3.6 A	2.05 A	5.7 A	3.3 A	1.9 A

PALLETIZATION

MODEL		GROUPAGE / CONTAINER			
Single-phase	Three-phase	n° pumps	H (mm)	kg	
				1~	3~
PKm 60-Bz	PK 60-Bz	192	1460	1100	1100
PKm 65-Bz	PK 65-Bz	216	1630	1580	1490

MODEL		GROUPAGE / CONTAINER			
Single-phase	Three-phase	n° pumps	H (mm)	kg	
				1~	3~
PQm 60-Bz	PQ 60-Bz	192	1460	1080	1080
PQm 65-Bz	PQ 65-Bz	216	1630	1530	1420
PQm 70-Bz	PQ 70-Bz	120	1270	1220	1110
PQm 80-Bz	PQ 80-Bz	120	1270	1220	1110
PQm 90-Bz	PQ 90-Bz	120	1280	1240	1110
PQm 100-Bz	PQ 100-Bz	72	1490	1120	990

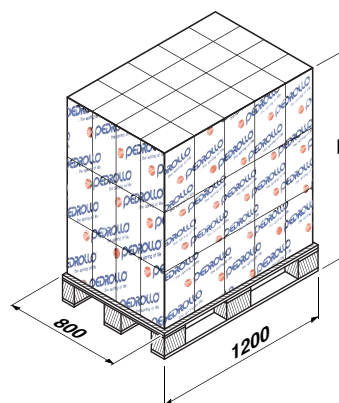

PK-PQ / I

Pumps with stainless steel pump body



PERFORMANCE RANGE

- Flow rate up to **40 l/min** (2.4 m³/h)
- Head up to **40 m**

APPLICATION LIMITS

- Manometric suction lift up to **8 m**
- Liquid temperature between **-10 °C** and **+90 °C**
- Ambient temperature up to **+40 °C**
- Max. working pressure **10 bar**
- Continuous service **S1**

CONSTRUCTION AND SAFETY STANDARDS

EN 60034-1
IEC 60034-1
CEI 2-3



CERTIFICATIONS



AN30

INSTALLATION AND USE

Suitable for use with clean water that does not contain abrasive particles and liquids that are not chemically aggressive towards the materials from which the pump is made.

The design solution of these pumps guarantees against the formation of rust and oxidation. As a result of their compact design and characteristic curves they are suitable for use in industrial applications such as cooling and conditioning, etc.

The pump should be installed in an enclosed environment, or at least sheltered from inclement weather.

PATENTS - TRADE MARKS - MODELS

- Motor bracket: patent n° IT1243605

OPTIONALS AVAILABLE ON REQUEST

- Special mechanical seal
- Other voltages or 60 Hz frequency
- IP 55 class protection

GUARANTEE

1 year subject to terms and conditions

CHARACTERISTIC CURVES AND PERFORMANCE DATA

50 Hz n= 2900 1/min HS= 0 m

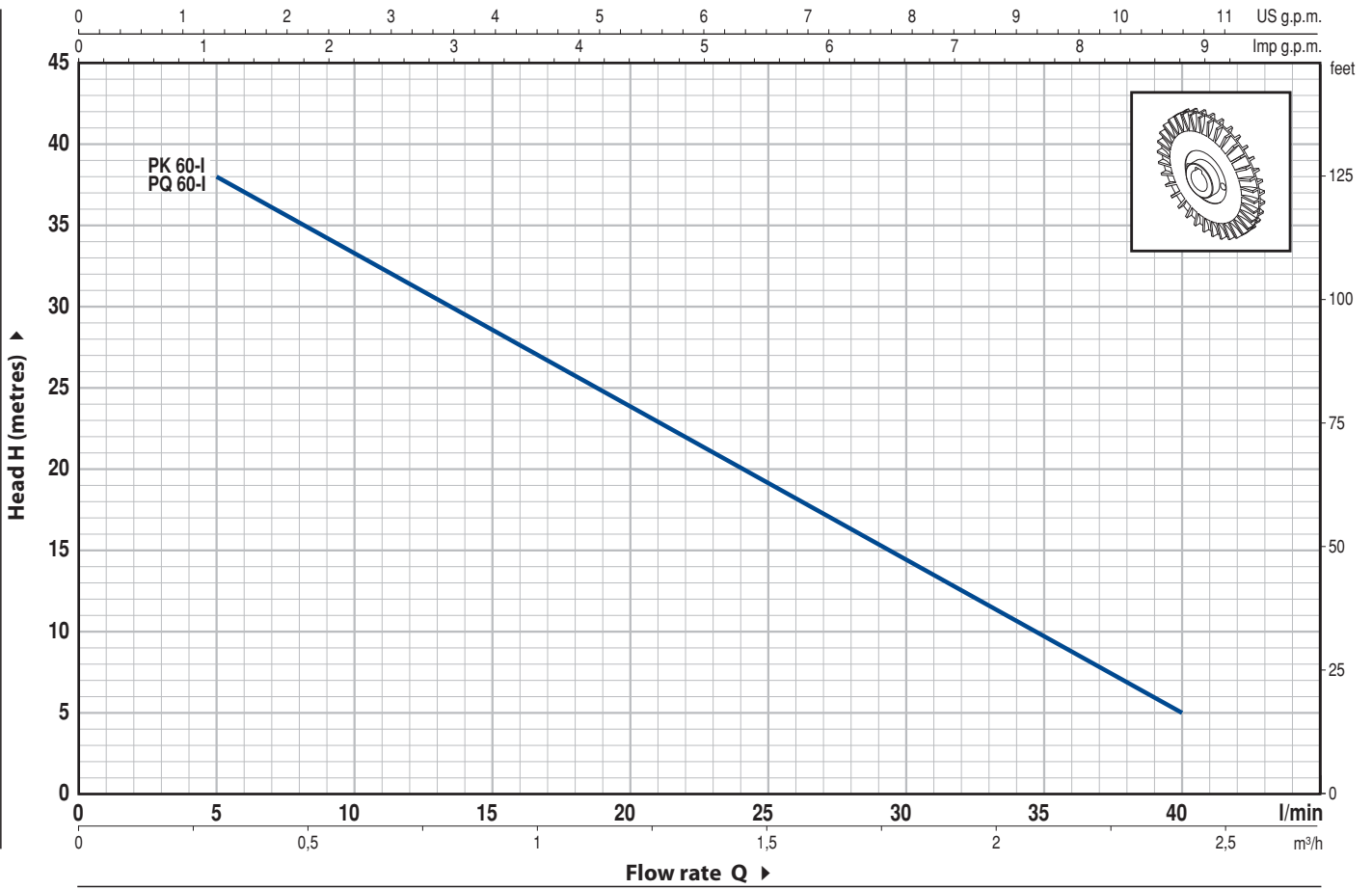

MODEL		POWER		Q	0	0.3	0.6	0.9	1.2	1.5	1.8	2.1	2.4
Single-phase	Three-phase	kW	HP		0	5	10	15	20	25	30	35	40
PKm 60-I	PK 60-I	0.37	0.50	H metres	40	38	33.5	29	24	19.5	15	10	5
PQm 60-I	PQ 60-I												

Q = Flow rate H = Total manometric head HS = Suction height

Tolerance of characteristic curves in compliance with EN ISO 9906 App. A.

POS.	COMPONENT	CONSTRUCTION CHARACTERISTICS					
1	PUMP BODY	Precision cast stainless steel AISI 316, complete with threaded ports in compliance with ISO 228/1					
2	MOTOR BRACKET	Aluminium with brass insert (patented), reduces the risk of impeller seizure					
3	IMPELLER	Brass, with peripheral radial vanes					
4	MOTOR SHAFT	Stainless steel AISI 316					
5	MECHANICAL SEAL	<i>Pump Model</i>	<i>Seal Model</i>	<i>Shaft Diameter</i>	<i>Stationary ring</i>	<i>Rotational ring</i>	<i>Elastomer</i>
		PK 60-I PQ 60-I	FN-12V	Ø 12 mm	Graphite	Ceramic	Viton
6	BEARINGS	<i>Pump Model</i>	<i>Model</i>				
		PK 60-I PQ 60-I	6201 ZZ - C3 / 6201 ZZ - C3				
7	CAPACITOR	<i>Pump Single-phase</i>	<i>Capacitance (230 V or 240 V)</i>		<i>(110 V)</i>		
		PKm 60-I	10 µF 450 VL		25 µF 250 VL		
		PQm 60-I					
8	ELECTRIC MOTOR	PKm-I PQm-I: single-phase 230 V - 50 Hz with thermal overload protector built-in to the winding. PK-I PQ-I: three-phase 230/400 V - 50 Hz. ⇒ Pumps fitted with the three-phase motor option offer IE2 (IEC 60034-30) class high performance – Insulation: F class. – Protection: IP 44.					

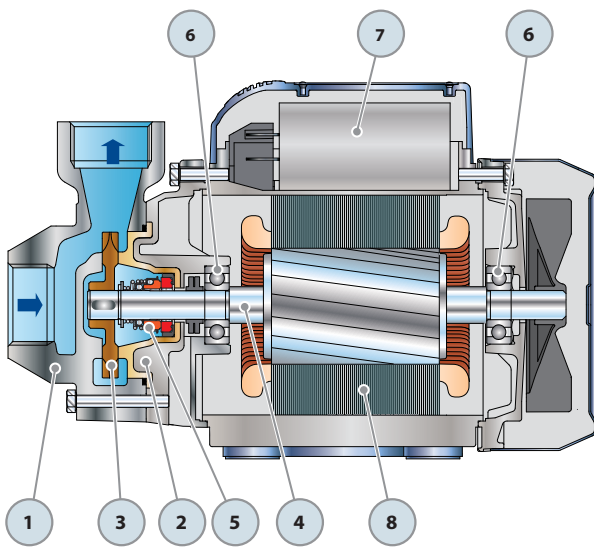

PK 60-I

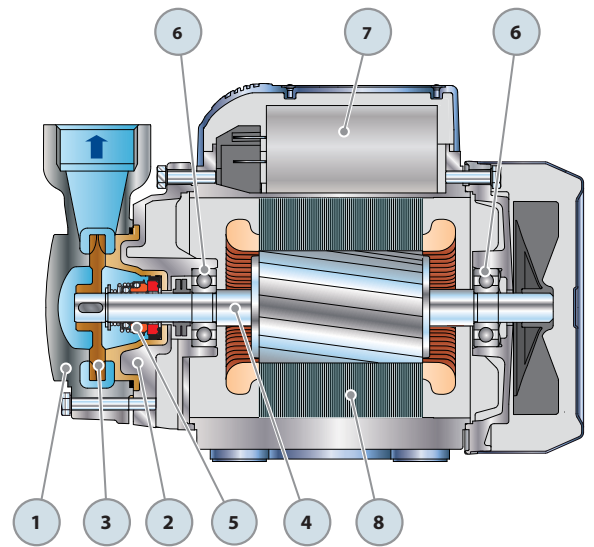

PQ 60-I

DIMENSIONS AND WEIGHT

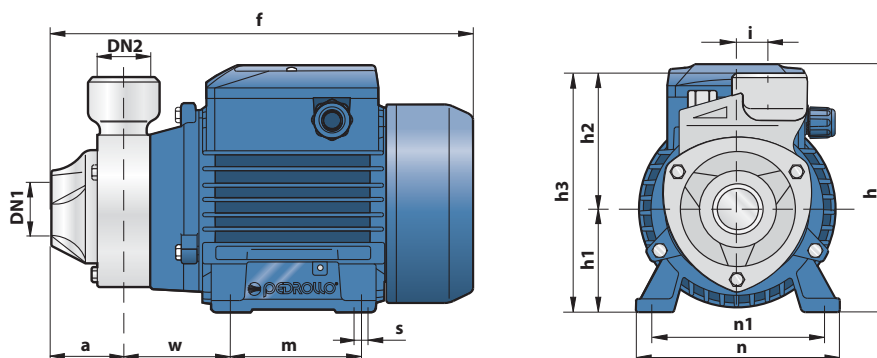

MODEL		PORTS		DIMENSIONS mm												kg	
Single-phase	Three-phase	DN1	DN2	a	f	h	h1	h2	h3	i	m	n	n1	w	s	1~	3~
PKm 60-I	PK 60-I	1"	1"	42	245	152	63	75	138	20	80	120	100	55	7	5.5	5.5

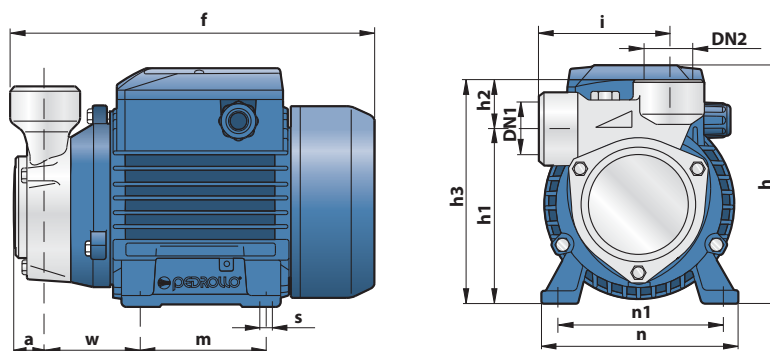

MODEL		PORTS		DIMENSIONS mm												kg	
Single-phase	Three-phase	DN1	DN2	a	f	h	h1	h2	h3	i	m	n	n1	w	s	1~	3~
PQm 60-I	PQ 60-I	1"	1"	22	225	152	108	30	138	78	80	120	100	55	7	5.4	5.4

ABSORPTION

MODEL	VOLTAGE (single-phase)		
Single-phase	230 V	240 V	110 V
PKm 60-I	2.5 A	2.4 A	5.0 A
PQm 60-I	2.5 A	2.4 A	5.0 A

MODEL	VOLTAGE (three-phase)					
Three-phase	230 V	400 V	690 V	240 V	415 V	720 V
PK 60-I	1.9 A	1.15 A	0.6 A	1.9 A	1.1 A	0.6 A
PQ 60-I	1.9 A	1.15 A	0.6 A	1.9 A	1.1 A	0.6 A

PALLETIZATION

MODEL		GROUPAGE / CONTAINER			
Single-phase	Three-phase	n° pumps	H (mm)	kg	
PKm 60-I	PK 60-I	192	1460	1080	1080
PQm 60-I	PQ 60-I	192	1460	1060	1060

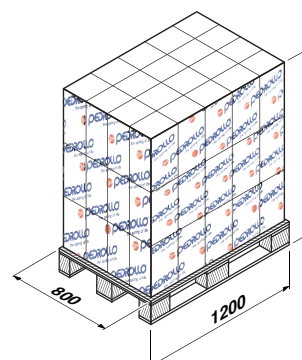



PERFORMANCE RANGE

- Flow rate up to **6000 l/min** (360 m³/h)
- Head up to **95 m**

APPLICATION LIMITS

- Manometric suction lift up to **7 m**
- Liquid temperature between **-10 °C** and **+90 °C**
- Ambient temperature between **-10 °C** and **+40 °C**
- Max. pressure in pump body **10 bar** (PN10)
- Continuous service **S1**

CONSTRUCTION AND SAFETY STANDARDS

EN 60034-1
IEC 60034-1
CEI 2-3



Pump body dimensions in compliance with **EN 733**

CERTIFICATIONS



INSTALLATION AND USE

- Water supply
- Pressure boosting
- Irrigation
- Water circulation in climatisation sets
- Cleaning sets
- Firefighting sets
- Industrial applications
- Agricultural applications

The pumps must be installed in enclosed places, or at least protected against inclement weather.

OPTIONALS AVAILABLE ON REQUEST

- Special mechanical seal
- Other voltages or 60 Hz frequency
- Compatibility with hotter or colder liquids
- Compatibility with hotter or colder ambients

GUARANTEE

1 year subject to terms and conditions

PERFORMANCE RANGE

50 Hz n= 2900 1/min HS= 0 m

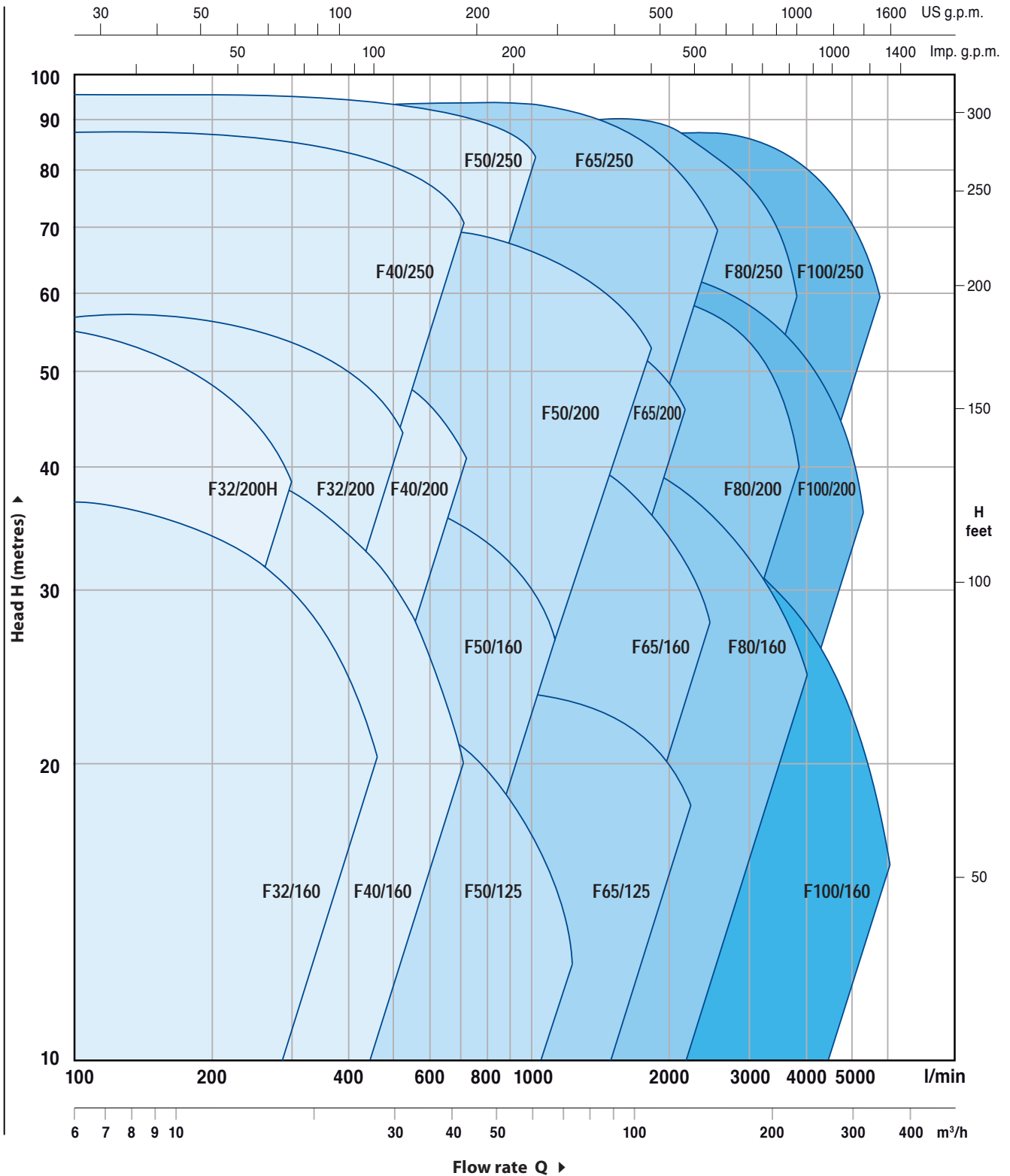

F32/160

CHARACTERISTIC CURVES AND PERFORMANCE DATA

50 Hz n= 2900 1/min HS= 0 m

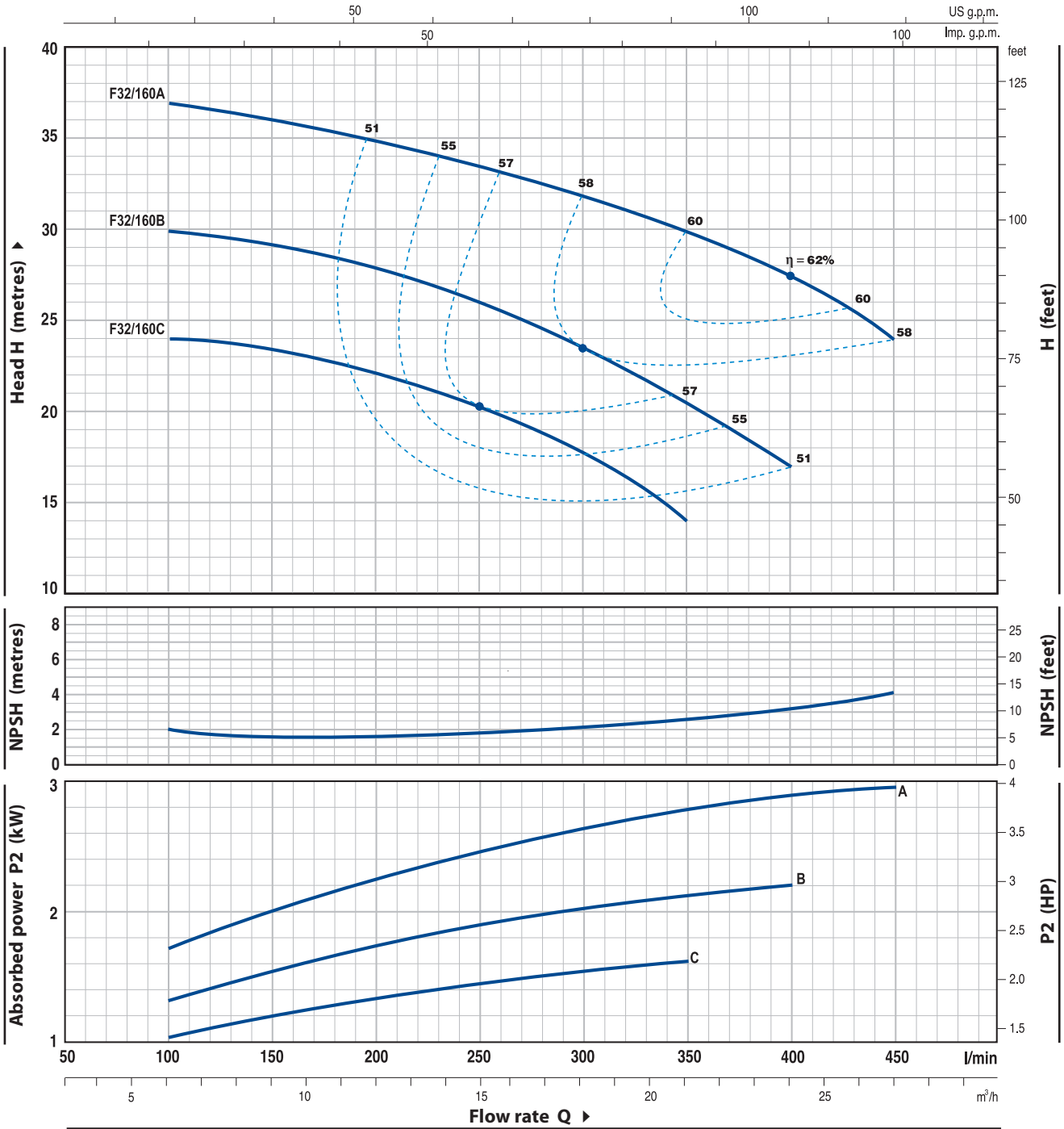

MODEL		POWER		Q	Flow rate									
Single-phase	Three-phase	kW	HP		m ³ /h	0	6	9	12	15	18	21	24	27
Fm 32/160C	F 32/160C	1.5	2	H metres	0	100	150	200	250	300	350	400	450	
Fm 32/160B	F 32/160B	2.2	3		25	24	23.5	22	20.5	18	14			
-	F 32/160A	3	4		31	30	29	28	26	23.5	20.5	17		
					38	37	36	35	33.5	31.5	30	27.5	24	

Q = Flow rate H = Total manometric head HS = Suction height

Tolerance of characteristic curves in compliance with EN ISO 9906 App. A.

CHARACTERISTIC CURVES AND PERFORMANCE DATA

50 Hz n= 2900 1/min HS= 0 m

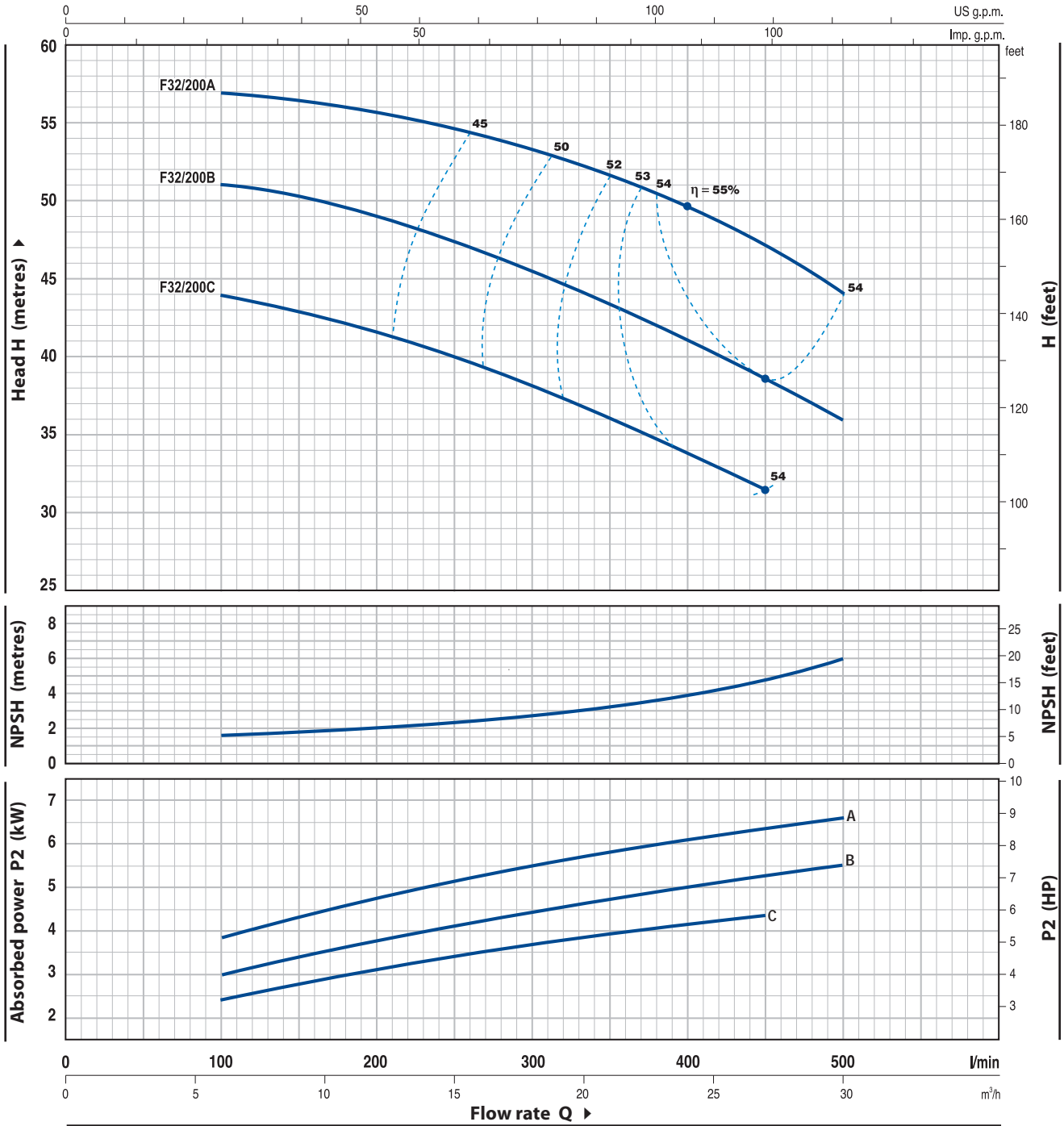

MODEL	POWER		Q	0	6	9	12	15	18	21	24	27	30
	kW	HP		0	100	150	200	250	300	350	400	450	500
Three-phase			H metres	46	44	43	41.5	40	38	36	34	31.5	
F 32/200C	4	5.5		52	51	50.5	49	47	45	43	41	38.5	36
F 32/200B	5.5	7.5		60	57	56.5	56	55	53.5	52	50	47	44

Q = Flow rate H = Total manometric head HS = Suction height

Tolerance of characteristic curves in compliance with EN ISO 9906 App. A.

F32/200H

CHARACTERISTIC CURVES AND PERFORMANCE DATA

50 Hz n= 2900 1/min HS= 0 m

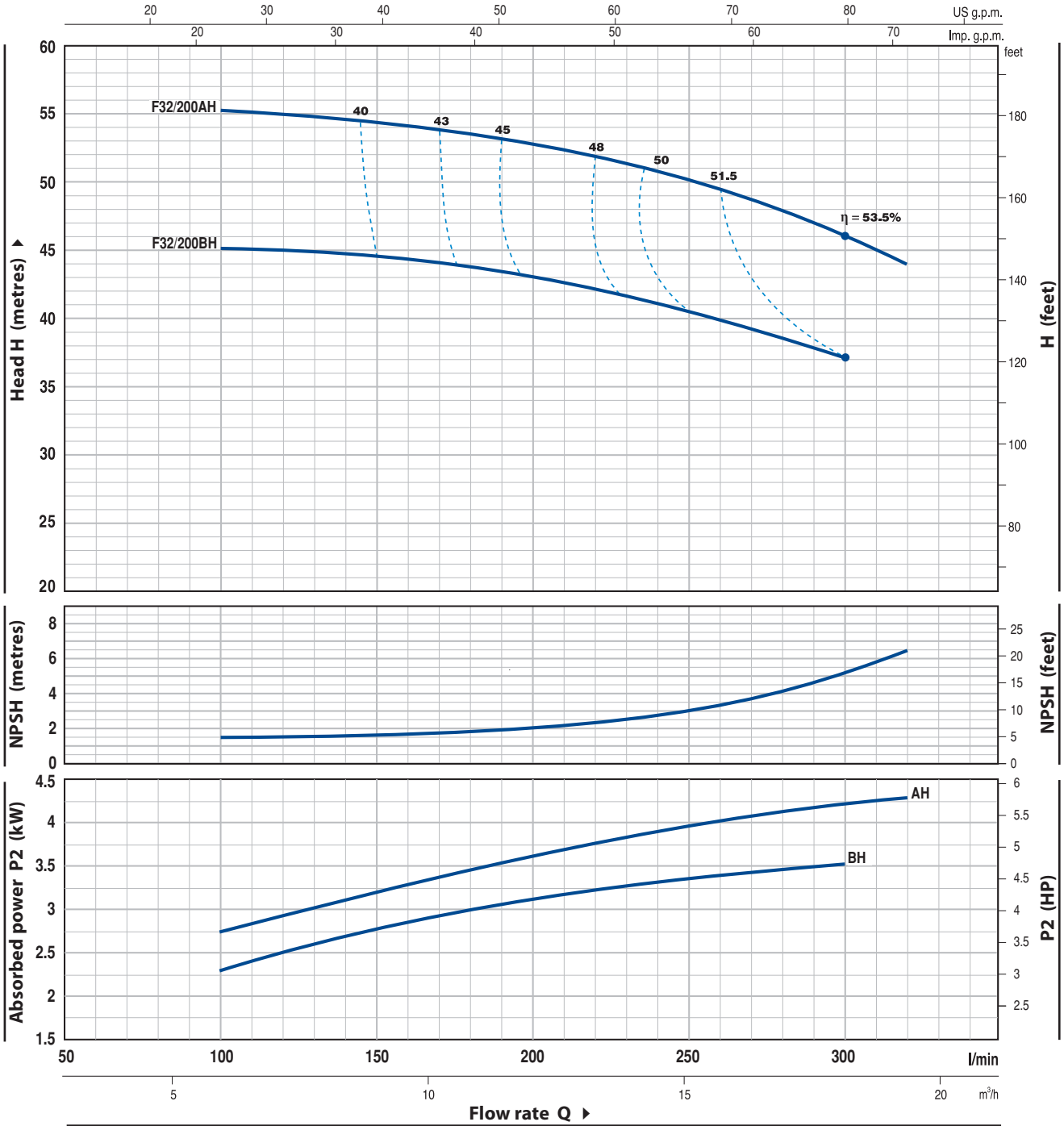

MODEL	POWER		Q	Flow rate Q						
	kW	HP		m ³ /h	l/min	l/min	l/min	l/min	l/min	l/min
Three-phase				0	6	9	12	15	18	19.2
F 32/200BH	3	4	H metres	47	45	44.5	43	40.5	37	
F 32/200AH	4	5.5	H metres	57	55	54	52.5	50	46	44

Q = Flow rate H = Total manometric head HS = Suction height

Tolerance of characteristic curves in compliance with EN ISO 9906 App. A.

CHARACTERISTIC CURVES AND PERFORMANCE DATA

50 Hz n= 2900 1/min HS= 0 m

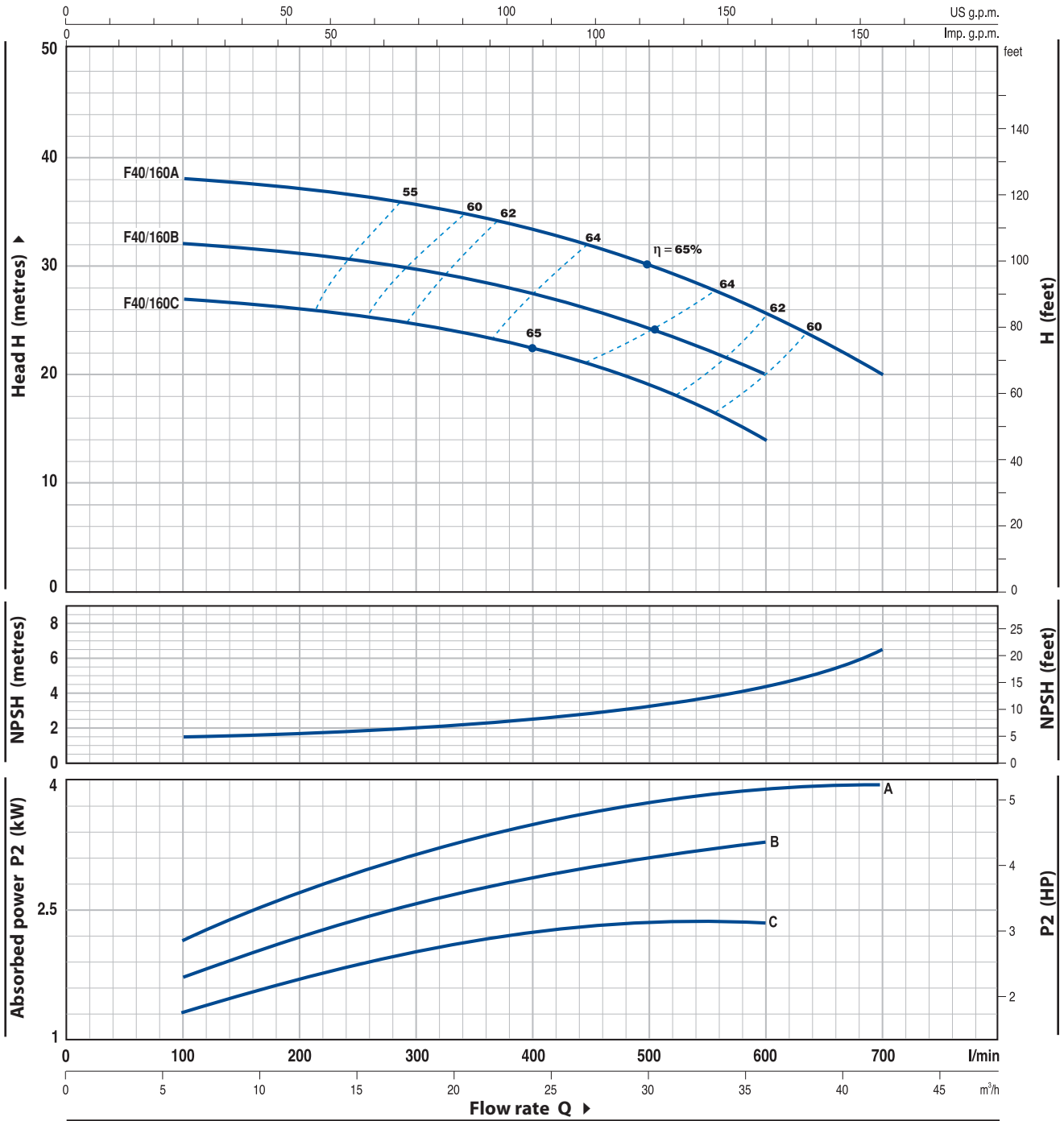

MODEL		POWER		Q	Flow rate												
Single-phase	Three-phase	kW	HP		0	6	9	12	15	18	24	30	36	42			
Fm 40/160C	F 40/160C	2.2	3	l/min	0	100	150	200	250	300	400	500	600	700			
-	F 40/160B	3	4	H metres	27	27	26.5	26	25.5	25	22.5	19	14				
-	F 40/160A	4	5.5		32	32	31.5	31	30.5	30	27.5	24	20				
					38	38	37.8	37	36.5	36	33.5	30	26	20			

Q = Flow rate H = Total manometric head HS = Suction height

Tolerance of characteristic curves in compliance with EN ISO 9906 App. A.

F40/200

CHARACTERISTIC CURVES AND PERFORMANCE DATA

50 Hz n= 2900 1/min HS= 0 m

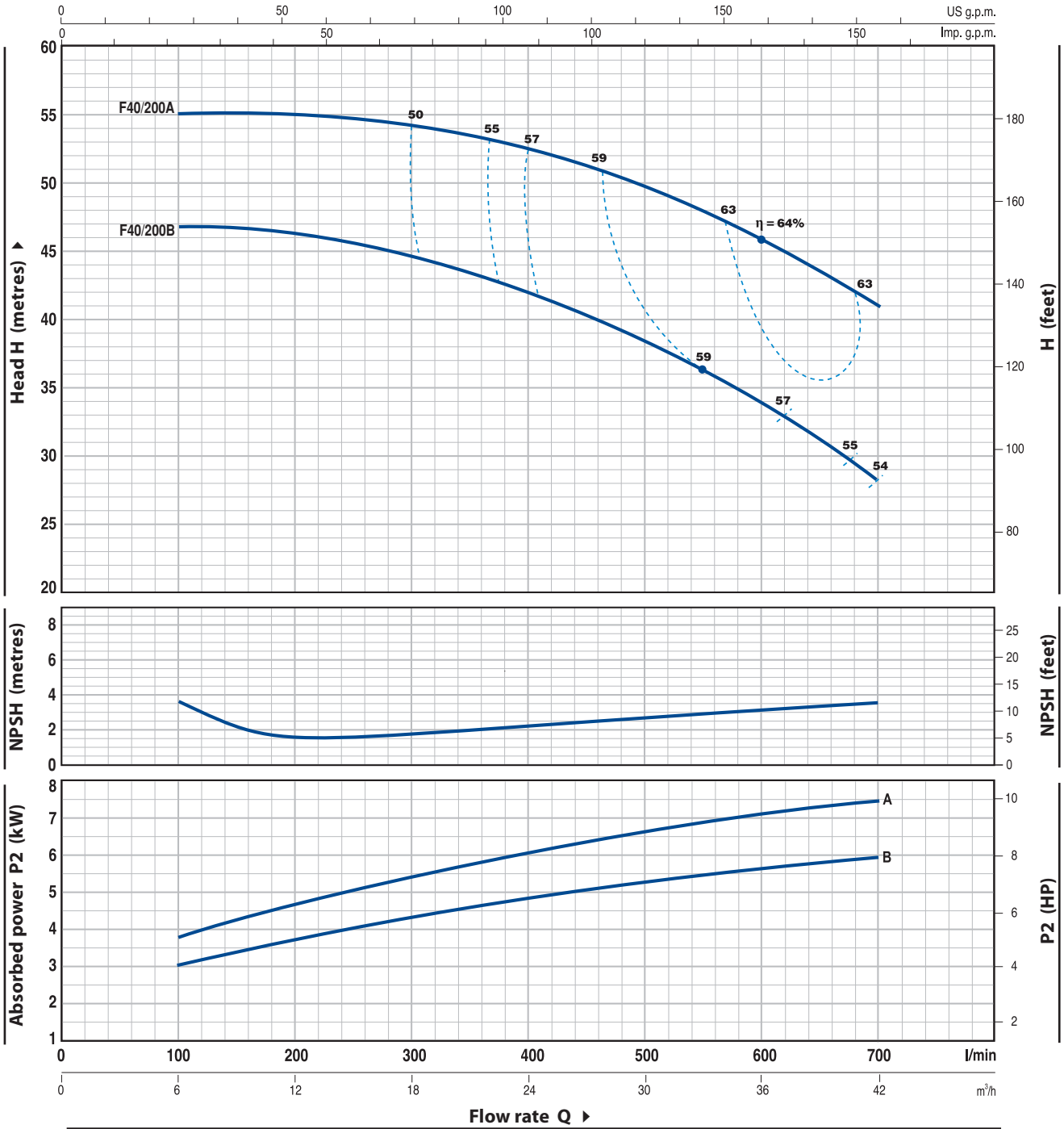

MODEL	POWER		Q	0	6	9	12	15	18	24	30	36	42
	kW	HP		0	100	150	200	250	300	400	500	600	700
Three-phase			H metres	48	47	46.5	46	45.5	44.5	42	38	34	28
F 40/200B	5.5	7.5		56	55	55	55	54.5	54	52.5	49.5	46	41
F 40/200A	7.5	10											

Q = Flow rate H = Total manometric head HS = Suction height

Tolerance of characteristic curves in compliance with EN ISO 9906 App. A.

CHARACTERISTIC CURVES AND PERFORMANCE DATA

50 Hz n= 2900 1/min HS= 0 m

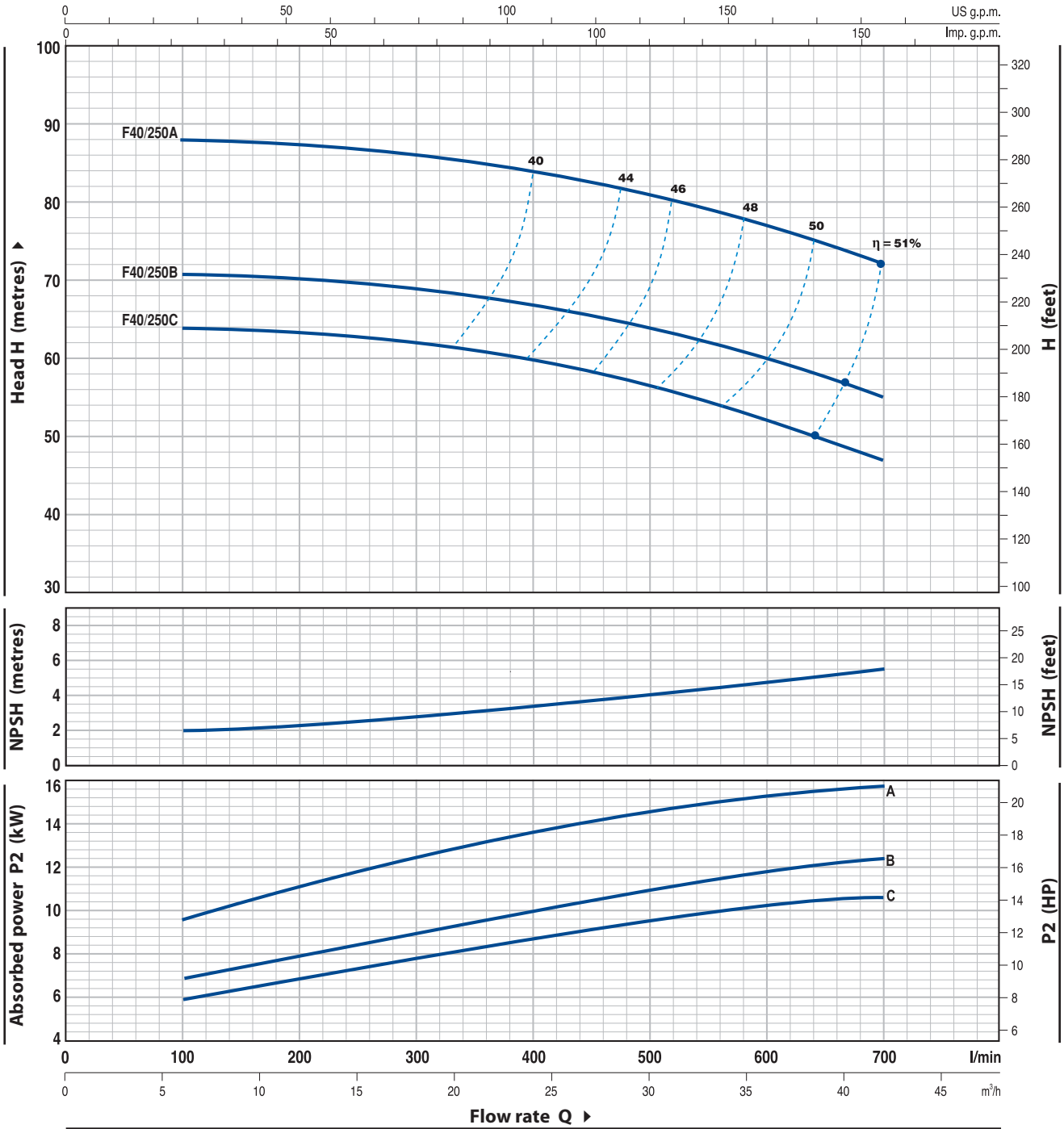

MODEL	POWER		Q	Flow rate												
	kW	HP		0	6	9	12	15	18	24	30	36	42			
Three-phase			Q	0	100	150	200	250	300	400	500	600	700			
F 40/250C	9.2	12.5	H metres	64	64	63.5	63	62.5	62	60	56.5	52.5	47			
F 40/250B	11	15		71	71	70.5	70	69.5	69	67	64	60	55			
F 40/250A	15	20		88	88	87.5	87	86.5	86	84	81	77	72			

Q = Flow rate H = Total manometric head HS = Suction height

Tolerance of characteristic curves in compliance with EN ISO 9906 App. A.

F50/125

CHARACTERISTIC CURVES AND PERFORMANCE DATA

50 Hz n= 2900 1/min HS= 0 m

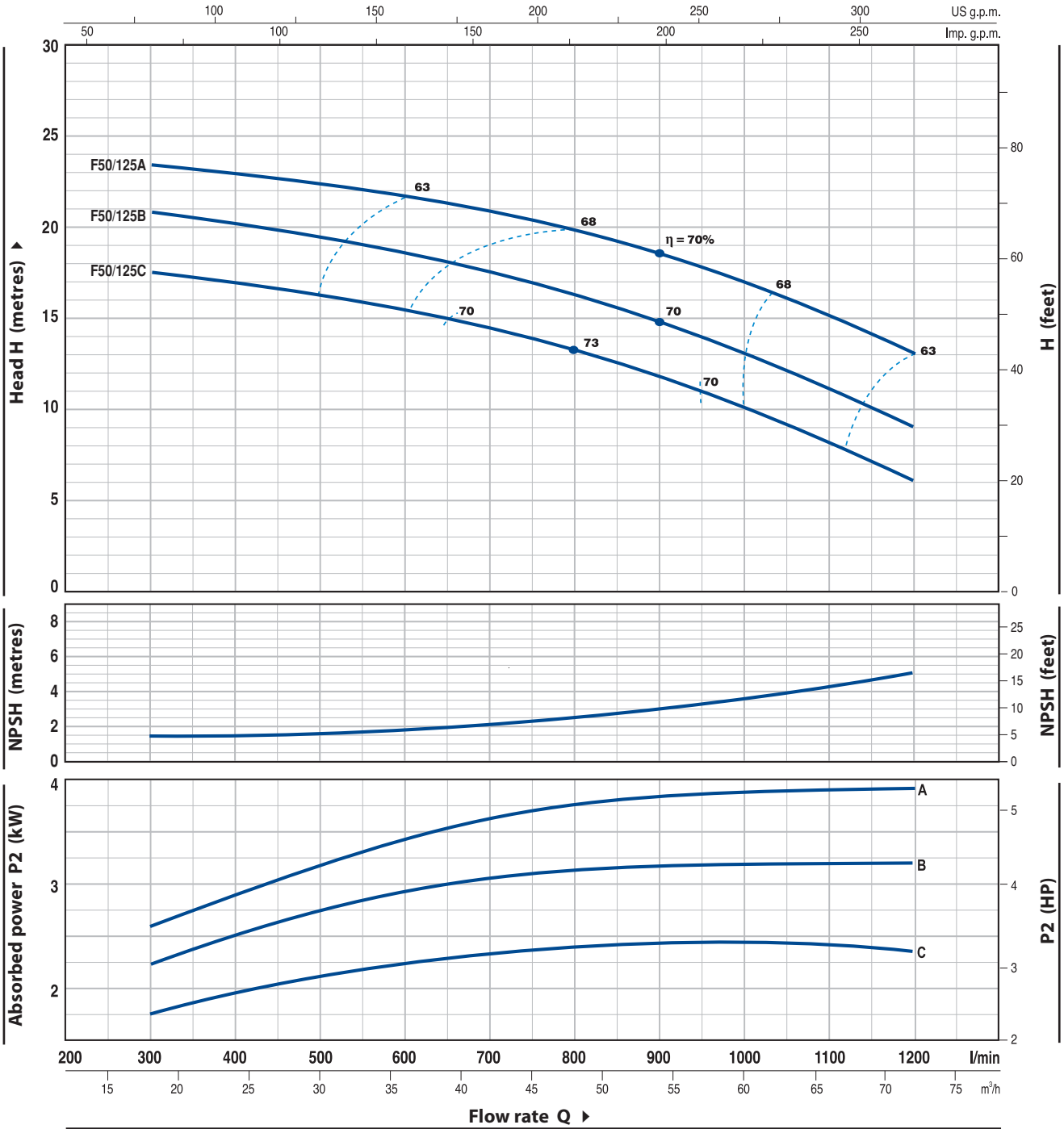

MODEL		POWER		Q	Flow rate													
Single-phase	Three-phase	kW	HP		0	18	24	30	36	42	48	54	60	66	72			
Fm 50/125C	F 50/125C	2.2	3	H metres	18.5	17.5	17	16.5	15.5	14.8	13.5	12	10.5	8.2	6			
-	F 50/125B	3	4		21.5	20.7	20	19.5	18.8	17.8	16.5	15	13.5	11.2	9			
-	F 50/125A	4	5.5		24.5	23.5	23	22.5	21.8	20.8	19.5	18.3	16.8	15	13			

Q = Flow rate H = Total manometric head HS = Suction height

Tolerance of characteristic curves in compliance with EN ISO 9906 App. A.

CHARACTERISTIC CURVES AND PERFORMANCE DATA

50 Hz n= 2900 1/min HS= 0 m

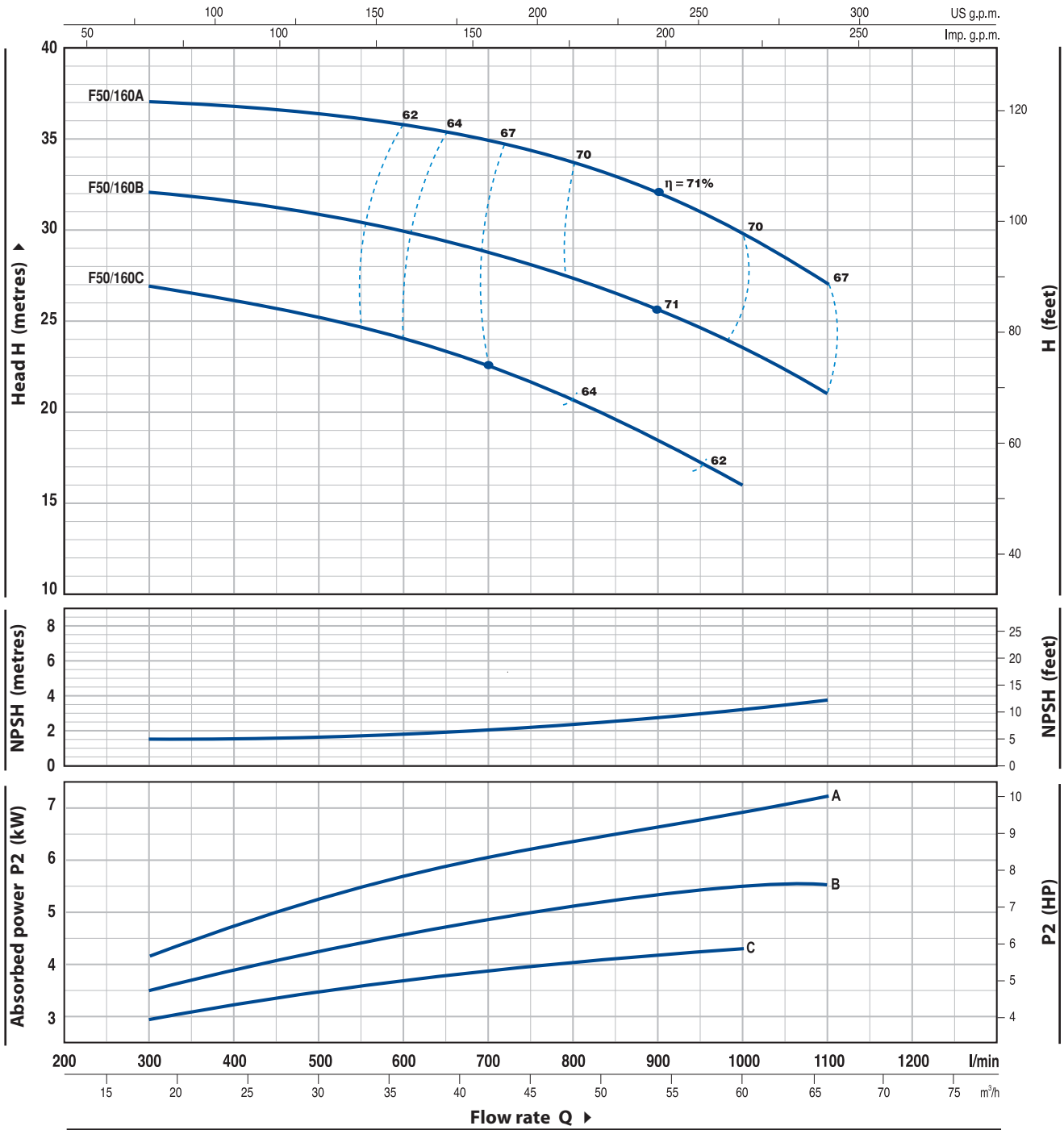

MODEL	POWER		Q	0	18	24	30	36	42	48	54	60	66
	kW	HP		0	300	400	500	600	700	800	900	1000	1100
Three-phase			H metres	27	27	26.5	25	24.5	23	20	18.5	16	
F 50/160C	4	5.5		33	32	31.7	31	30	29	27	26	24	21
F 50/160B	5.5	7.5		38	37	36.8	36.5	36	34	33	32	30	27

Q = Flow rate H = Total manometric head HS = Suction height

Tolerance of characteristic curves in compliance with EN ISO 9906 App. A.

F50/200

CHARACTERISTIC CURVES AND PERFORMANCE DATA

50 Hz n= 2900 1/min HS= 0 m

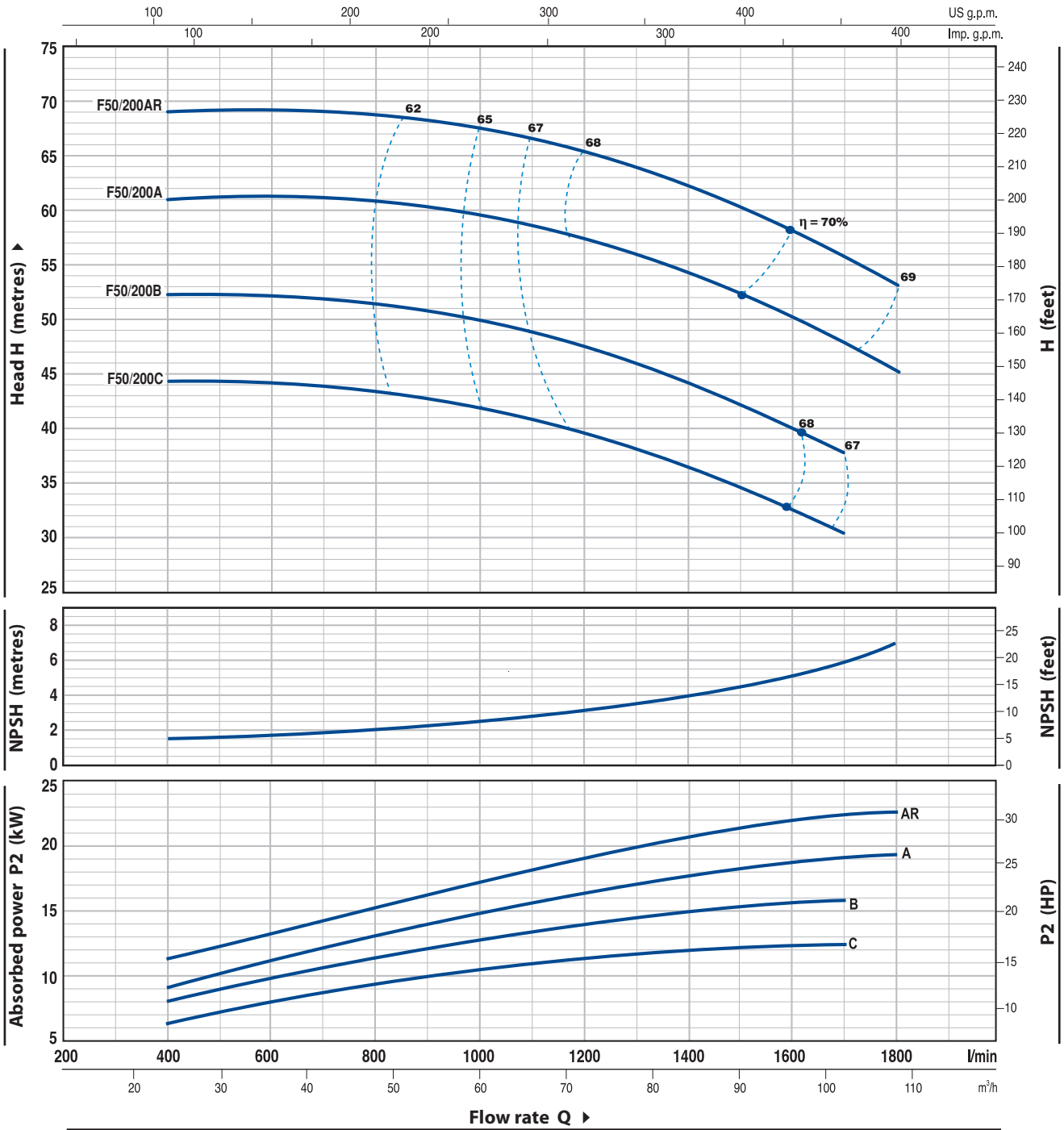

MODEL	POWER		Q	H metres											
	kW	HP		m ³ /h	24	36	48	60	72	84	96	102	108		
Three-phase			l/min	400	600	800	1000	1200	1400	1600	1700	1800			
F 50/200C	11	15		44	44	44	42	39	36	33	30				
F 50/200B	15	20		52	52	52	50	47	44	40	38				
F 50/200A	18.5	25		61	61	60.5	60	57	54	50	48	45			
F 50/200AR	22	30		69	69	68.5	68	65	62	58	56	53			

Q = Flow rate H = Total manometric head HS = Suction height

Tolerance of characteristic curves in compliance with EN ISO 9906 App. A.

CHARACTERISTIC CURVES AND PERFORMANCE DATA

50 Hz n= 2900 1/min HS= 0 m

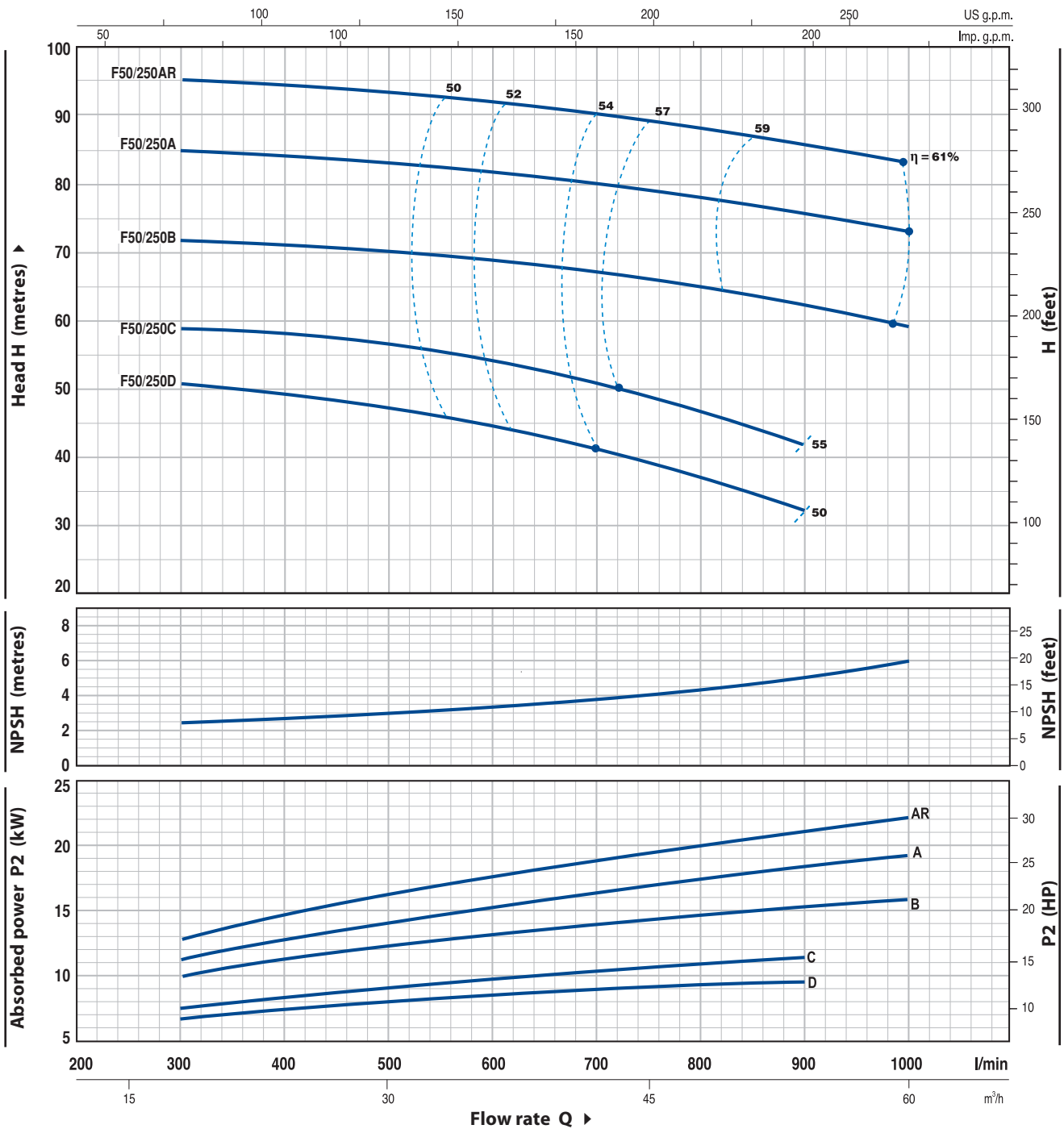

MODEL	POWER		Q	Flow rate Q											
	kW	HP		m ³ /h	0	18	24	30	36	42	48	54	60		
Three-phase			l/min	0	300	400	500	600	700	800	900	1000			
F 50/250D	9.2	12.5	H metres	51	51	49	47	44	41	37	32				
F 50/250C	11	15		59	59	58	57	54	51	47	42				
F 50/250B	15	20		72	72	71	70	69	67	65	62	59			
F 50/250A	18.5	25		85	85	84	83	82	80	78	76	73			
F 50/250AR	22	30		95	95	94	93	92	90	88	86	83			

Q = Flow rate H = Total manometric head HS = Suction height

Tolerance of characteristic curves in compliance with EN ISO 9906 App. A.

F65/125

CHARACTERISTIC CURVES AND PERFORMANCE DATA

50 Hz n= 2900 1/min HS= 0 m

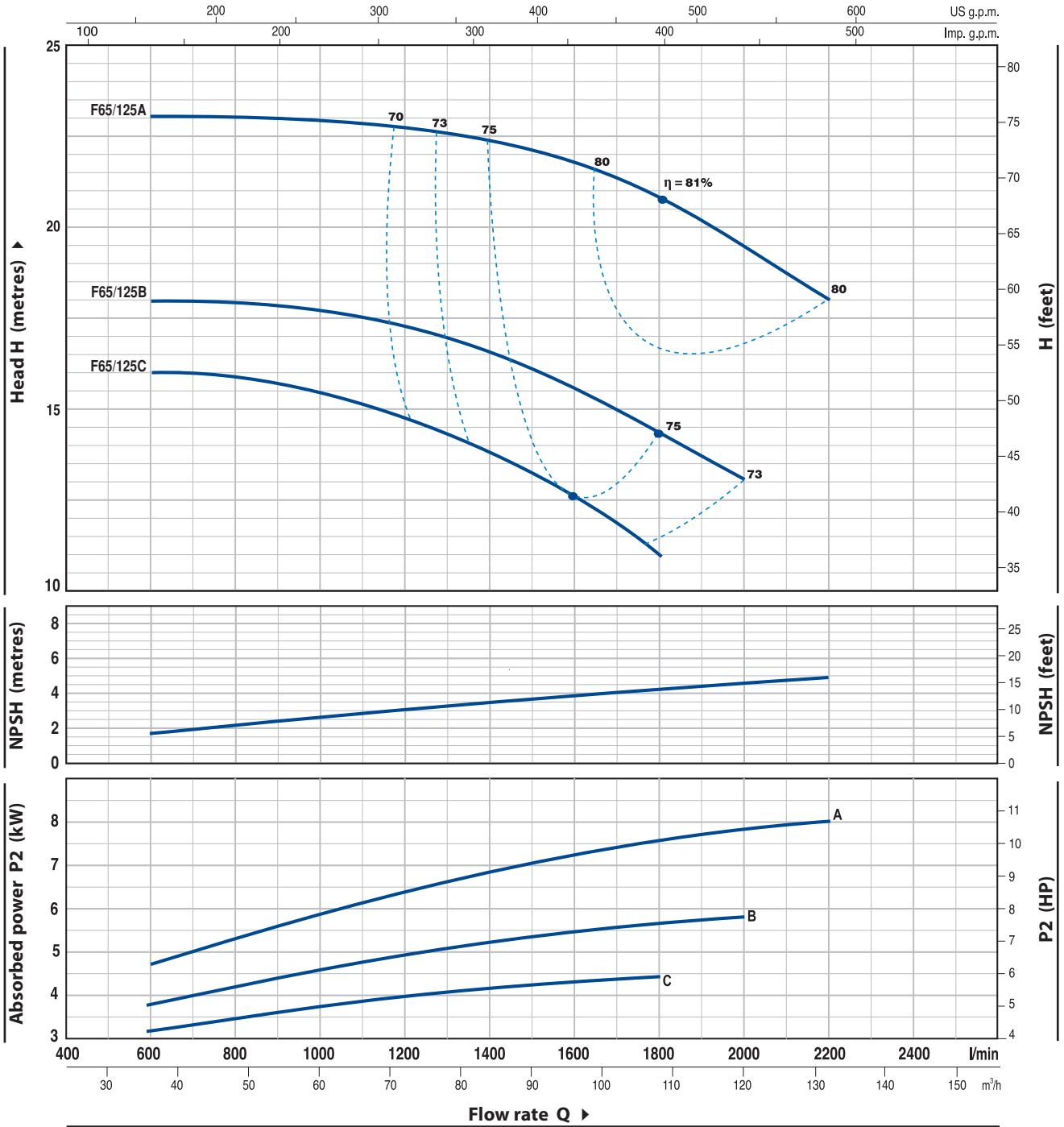

MODEL	POWER		Q	Flow rate												
	kW	HP		m ³ /h	0	36	48	60	72	84	96	108	120	132		
Three-phase			l/min	0	600	800	1000	1200	1400	1600	1800	2000	2200			
F 65/125C	4	5.5	H metres	16	16	16	15.5	14.5	13.5	12.5	11					
F 65/125B	5.5	7.5		18	18	18	18	17	16.5	15.5	14.5	13				
F 65/125A	7.5	10		23	23	23	23	22.5	22.5	22	21	19.5	18			

Q = Flow rate H = Total manometric head HS = Suction height

Tolerance of characteristic curves in compliance with EN ISO 9906 App. A.

CHARACTERISTIC CURVES AND PERFORMANCE DATA

50 Hz n= 2900 1/min HS= 0 m

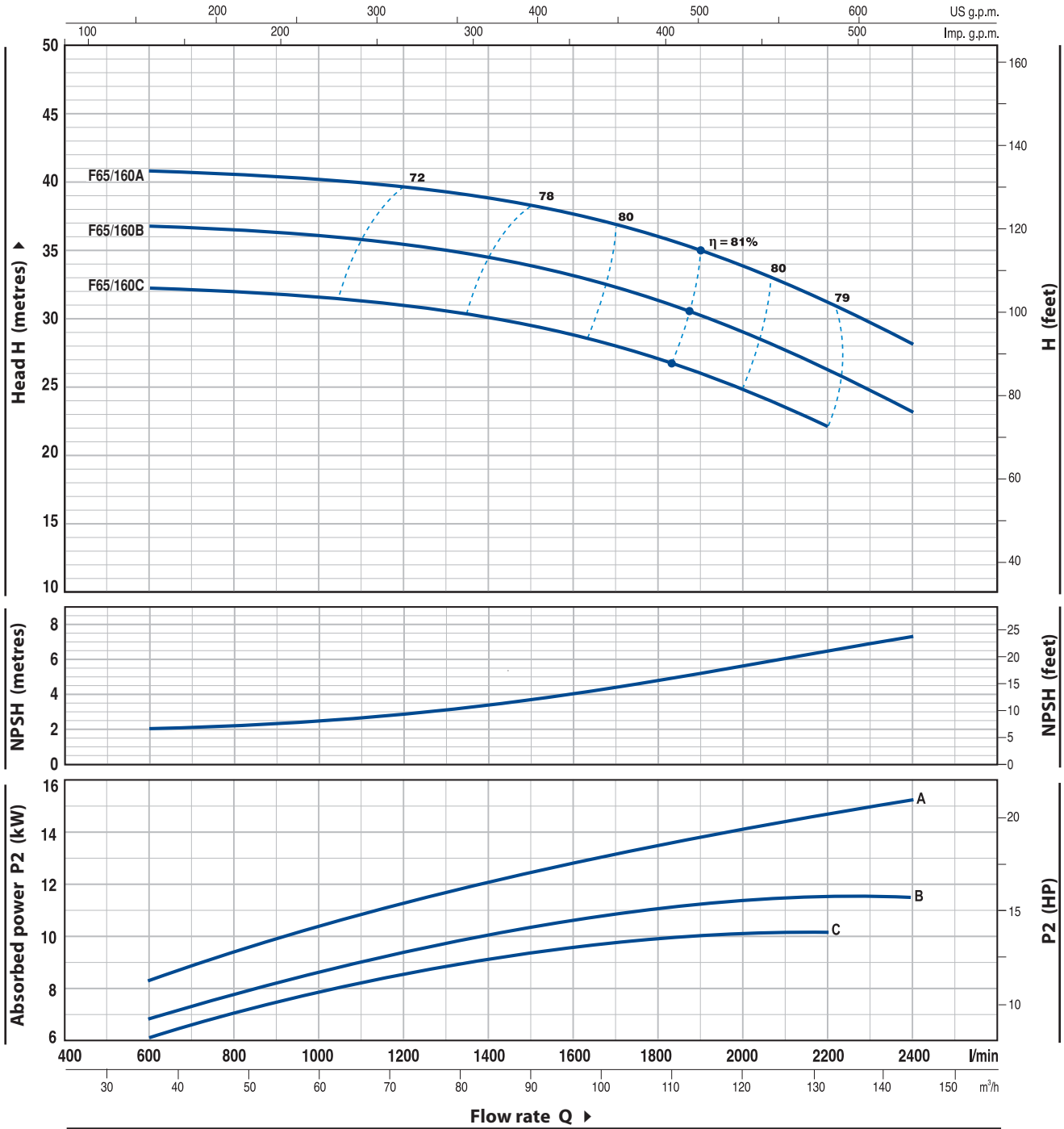

MODEL	POWER		Q	Flow rate													
	kW	HP		0	36	48	60	72	84	96	108	120	132	144			
Three-phase				0	600	800	1000	1200	1400	1600	1800	2000	2200	2400			
F 65/160C	9.2	12.5	H metres	32	32	32	32	32	30	29	27	25	22				
F 65/160B	11	15		37	36.5	36.5	36	35.5	34	33	31	29	26	23			
F 65/160A	15	20		41	40.5	40.5	40	39.5	39	37.5	36	34	31	28			

Q = Flow rate H = Total manometric head HS = Suction height

Tolerance of characteristic curves in compliance with EN ISO 9906 App. A.

F65/200

CHARACTERISTIC CURVES AND PERFORMANCE DATA

50 Hz n= 2900 1/min HS= 0 m

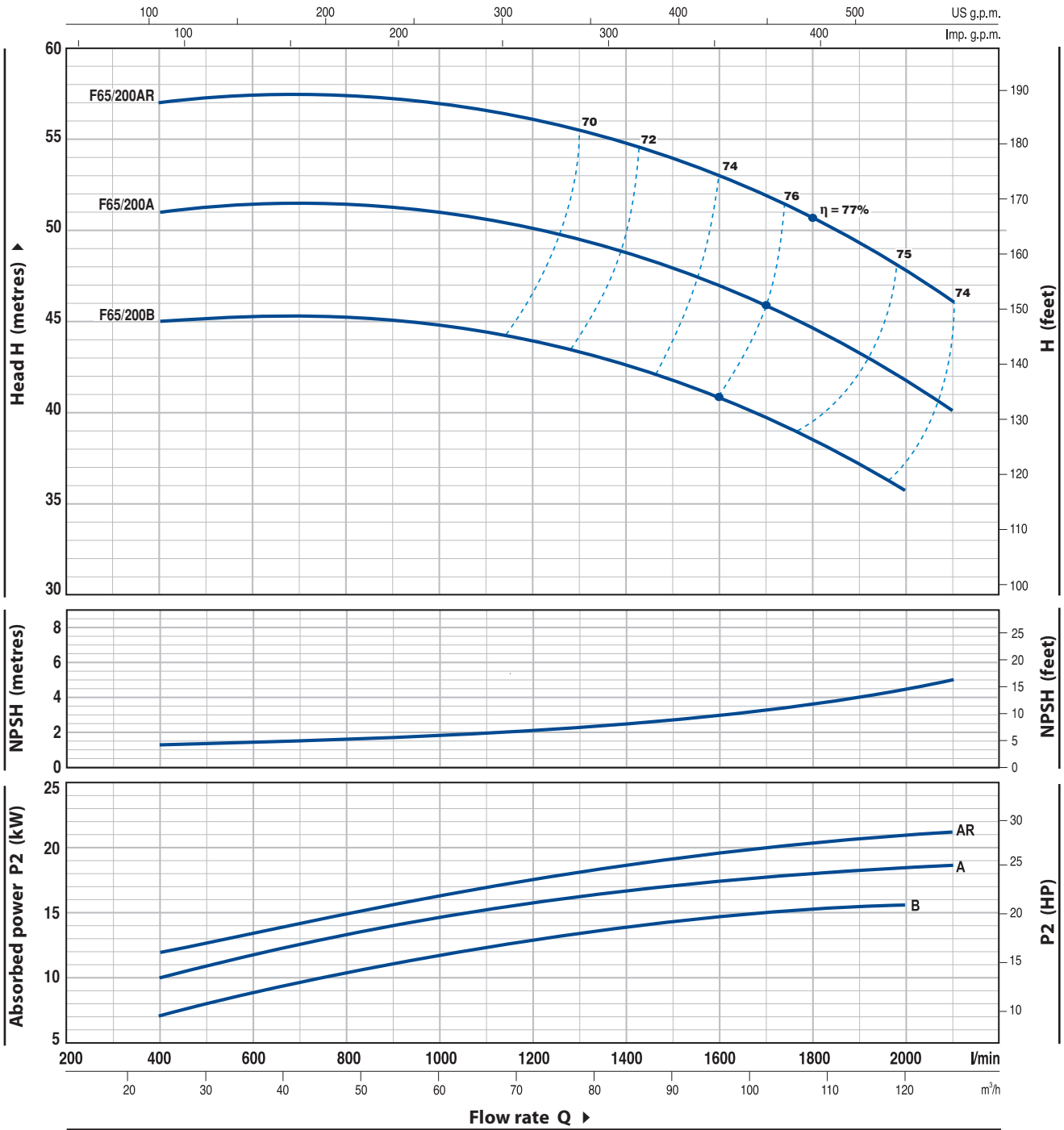

MODEL	POWER		Q	24	36	48	60	72	84	96	108	120	126
	kW	HP		400	600	800	1000	1200	1400	1600	1800	2000	2100
Three-phase			l/min										
F 65/200B	15	20	H metres	45	45	45	45	44	42.5	41	38.5	35.5	
F 65/200A	18.5	25		51	51	51	51	50	49	47	44.5	41.5	40
F 65/200AR	22	30		57	57	57	57	56	55	53	50.5	47.5	46

Q = Flow rate H = Total manometric head HS = Suction height

Tolerance of characteristic curves in compliance with EN ISO 9906 App. A.

CHARACTERISTIC CURVES AND PERFORMANCE DATA

50 Hz n= 2900 1/min HS= 0 m

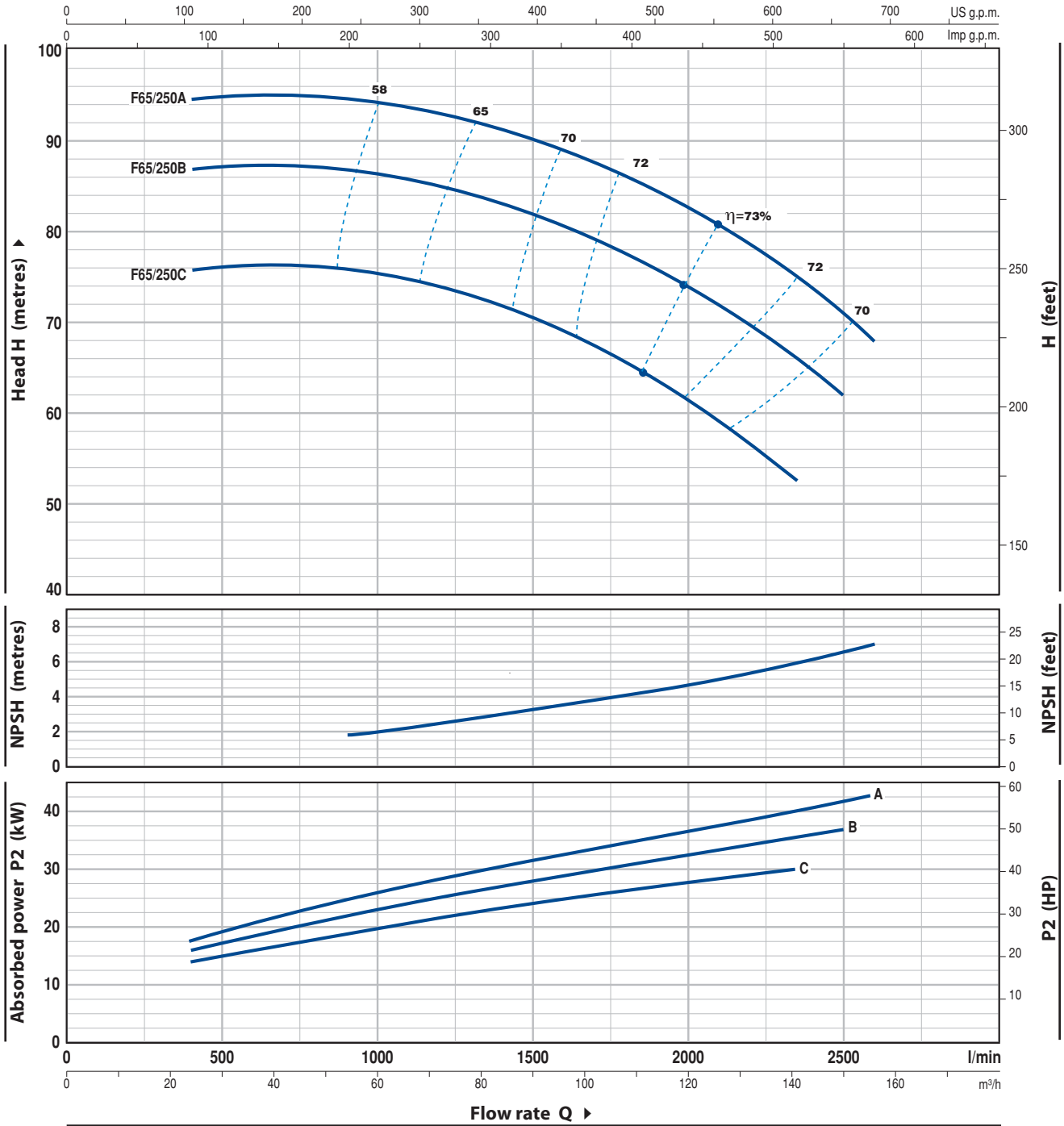

MODEL	POWER		Q	24	40	60	80	100	120	141	150	156
	kW	HP		m³/h	400	667	1000	1333	1667	2000	2350	2500
Three-phase			H metres	76	76	75.5	72.5	68	61.5	53		
F 65/250C	30	40		87	87	86	84	80	74	66.5	62	
F 65/250B	37	50		94.5	95	94	92	88	82.5	75	71	68
F 65/250A	45	60										

Q = Flow rate H = Total manometric head HS = Suction height

Tolerance of characteristic curves in compliance with EN ISO 9906 App. A.

F80/160

CHARACTERISTIC CURVES AND PERFORMANCE DATA

50 Hz n= 2900 1/min HS= 0 m

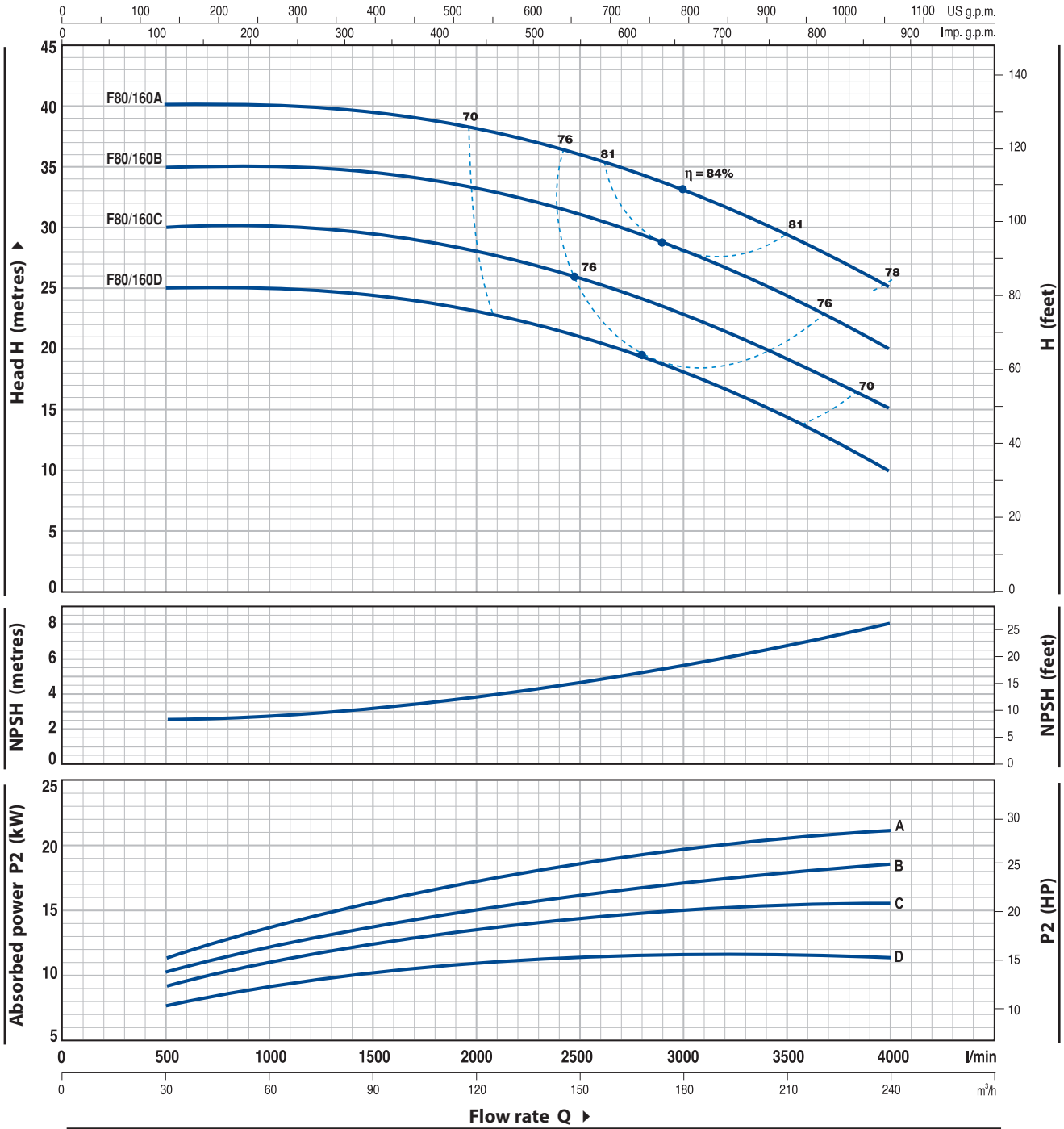

MODEL	POWER		Q	H metres											
	kW	HP		m ³ /h	0	30	60	90	120	150	180	210	240		
Three-phase			l/min	0	500	1000	1500	2000	2500	3000	3500	4000			
F 80/160D	11	15		25	25	25	24.5	23.5	21	18	14.5	10			
F 80/160C	15	20		30	30	30	29.5	28.5	26	23	19.5	15			
F 80/160B	18.5	25		35	35	35	34.5	33.5	31	28.5	24.5	20			
F 80/160A	22	30		40	40	40	39.5	38.5	36	33	29.5	25			

Q = Flow rate H = Total manometric head HS = Suction height

Tolerance of characteristic curves in compliance with EN ISO 9906 App. A.

CHARACTERISTIC CURVES AND PERFORMANCE DATA

50 Hz n= 2900 1/min HS= 0 m

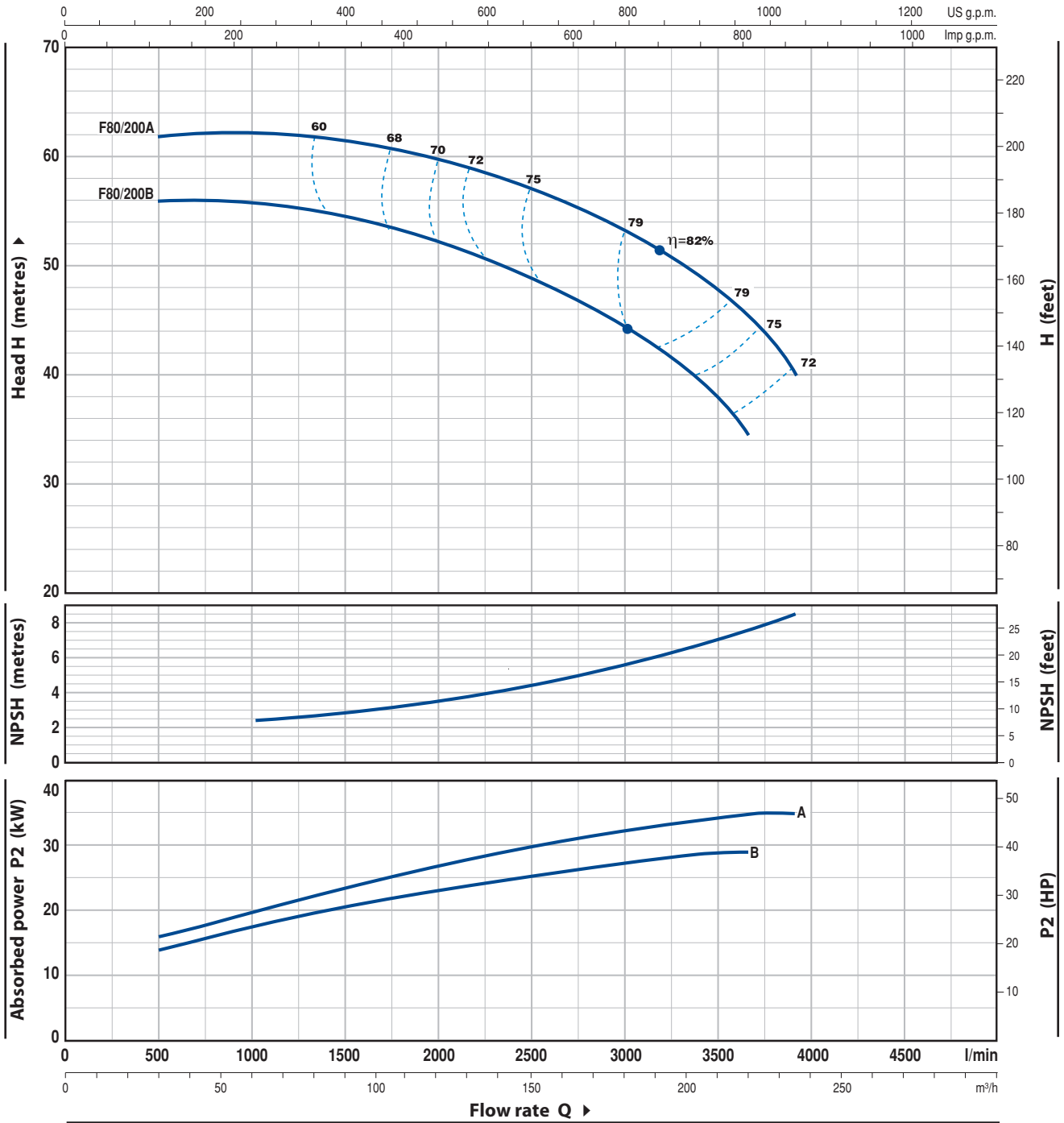

MODEL	POWER		Q	Flow rate							
	kW	HP		m ³ /h	30	50	100	150	200	219	234
Three-phase			l/min	500	833	1667	2500	3333	3650	3900	
F 80/200B	30	40	H metres	56	56	54	49	41	34.5		
F 80/200A	37	50		62	62	61	57	50	45.5	40	

Q = Flow rate H = Total manometric head HS = Suction height

Tolerance of characteristic curves in compliance with EN ISO 9906 App. A.

F80/250

CHARACTERISTIC CURVES AND PERFORMANCE DATA

50 Hz n= 2900 1/min HS= 0 m

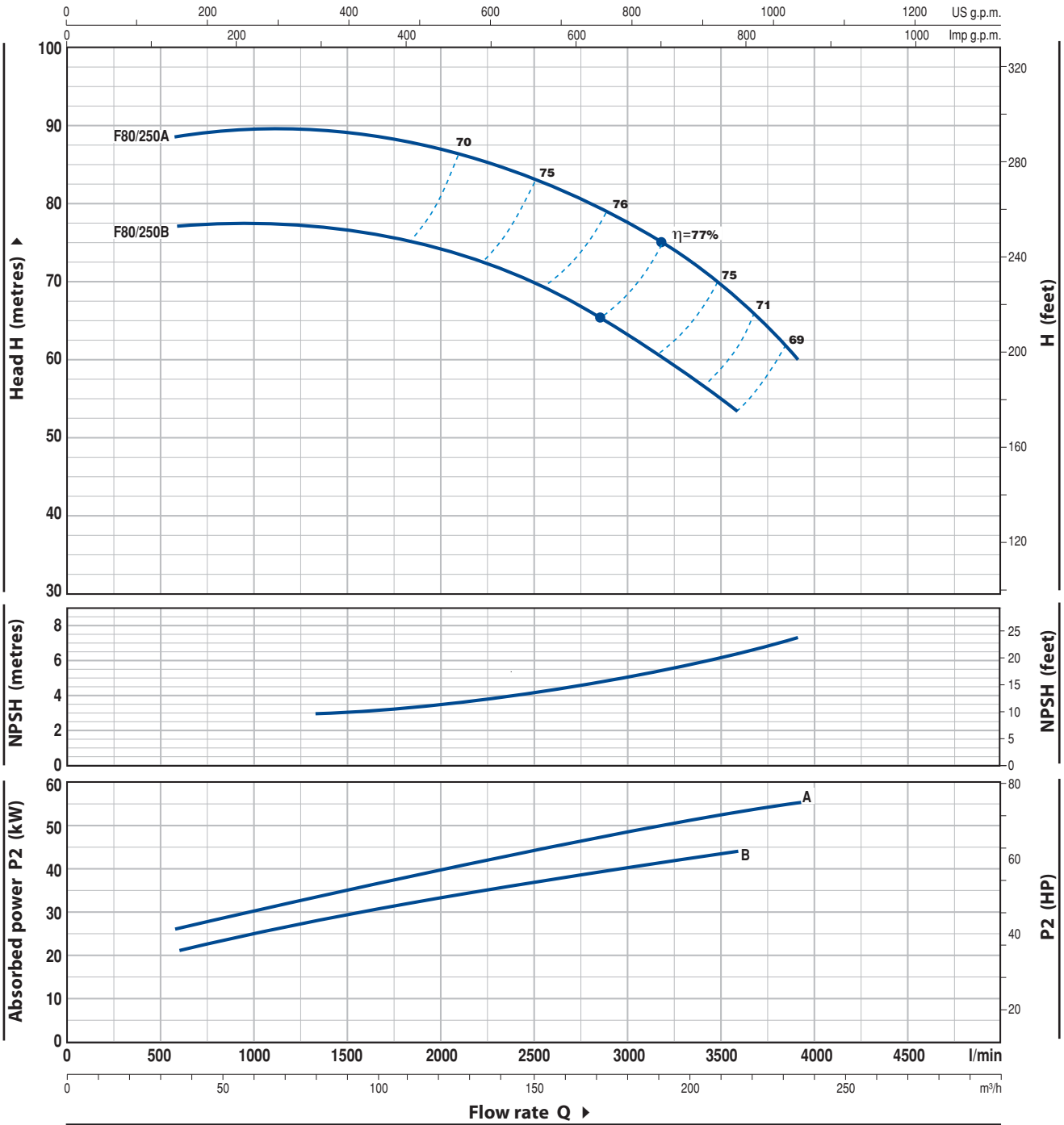

MODEL	POWER		Q	36	50	100	150	200	216	234
	kW	HP		m³/h	l/min	l/min	l/min	l/min	l/min	l/min
Three-phase				600	833	1667	2500	3333	3600	3900
F 80/250B	45	60	H metres	77	77.5	76	70.5	58.5	54	
F 80/250A	55	75		88.5	89.5	89	83	72	68	60

Q = Flow rate H = Total manometric head HS = Suction height

Tolerance of characteristic curves in compliance with EN ISO 9906 App. A.

CHARACTERISTIC CURVES AND PERFORMANCE DATA

50 Hz n= 2900 1/min HS= 0 m

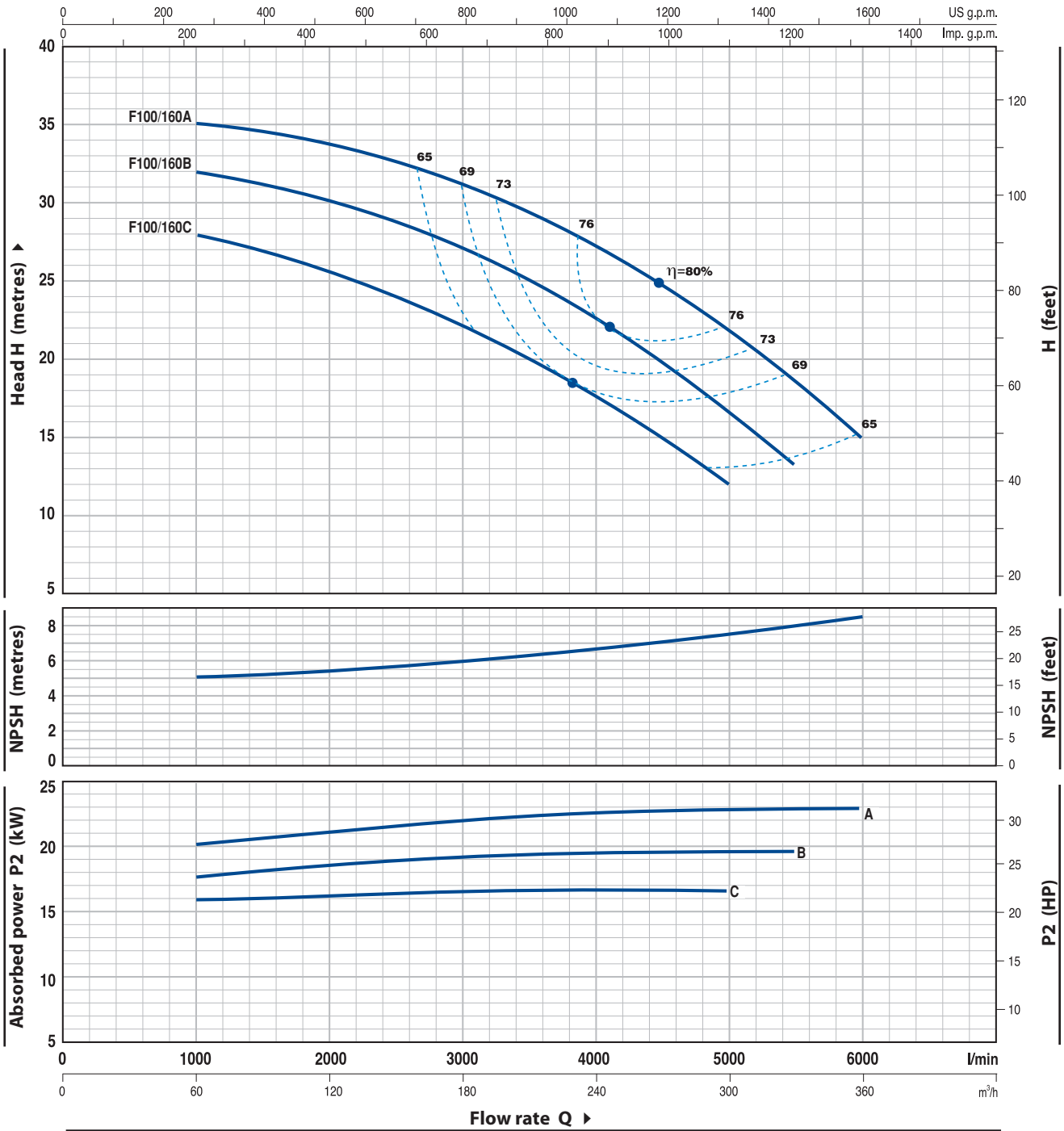

MODEL	POWER		Q	0	60	120	180	240	270	300	330	360
	kW	HP		0	1000	2000	3000	4000	4500	5000	5500	6000
F 100/160C	15	20	H metres	28	28	25.5	22	17.5	15	12		
F 100/160B	18.5	25		32	32	30	27	22.5	19.5	17	13	
F 100/160A	22	30		35	35	34	31	27	24.5	22	18	15

Q = Flow rate H = Total manometric head HS = Suction height

Tolerance of characteristic curves in compliance with EN ISO 9906 App. A.

F100/200

CHARACTERISTIC CURVES AND PERFORMANCE DATA

50 Hz n= 2900 1/min HS= 0 m

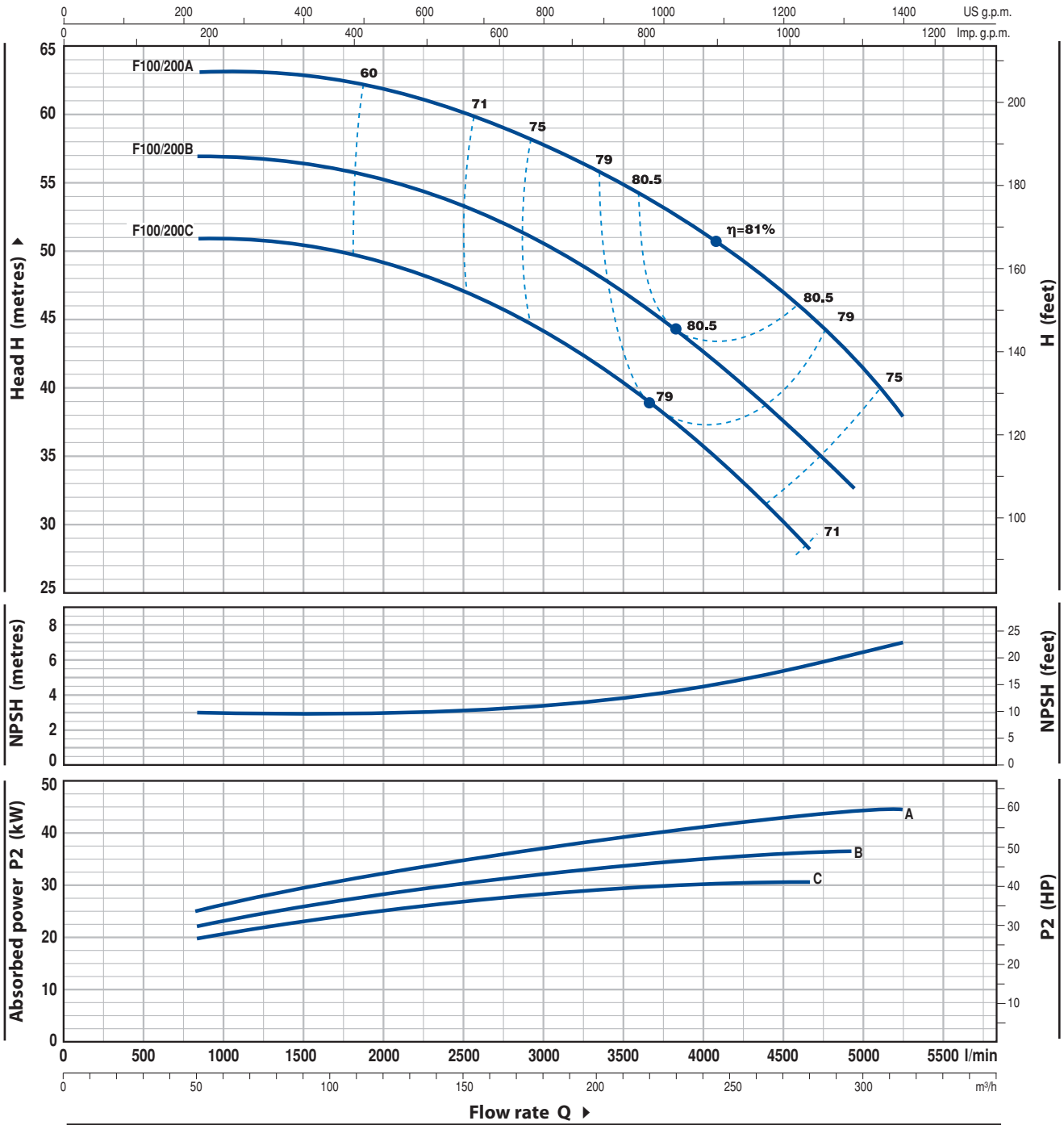

MODEL	POWER		Q	Flow rate											
	kW	HP		0	50	100	150	200	250	279	294	300	315		
Three-phase			l/min	0	833	1667	2500	3333	4167	4650	4900	5000	5250		
F 100/200C	30	40	H metres	51	51	50	47	41.5	34	28					
F 100/200B	37	50		57	57	56	53	48	41	36	33				
F 100/200A	45	60		63	63	62.5	60	56	50	45	42.5	41.5	38		

Q = Flow rate H = Total manometric head HS = Suction height

Tolerance of characteristic curves in compliance with EN ISO 9906 App. A.

CHARACTERISTIC CURVES AND PERFORMANCE DATA

50 Hz n= 2900 1/min HS= 0 m

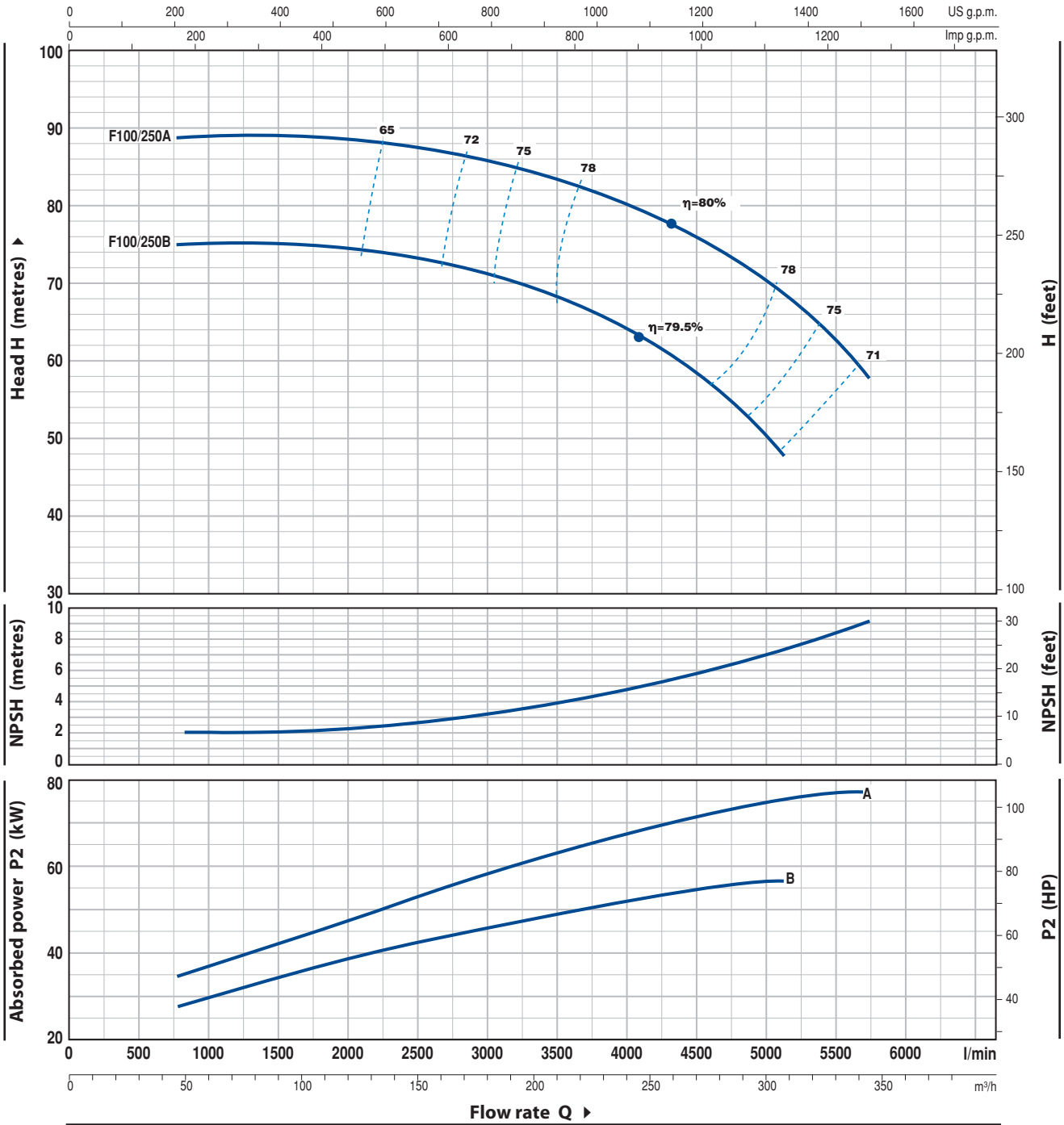

MODEL	POWER		Q	48	96	150	180	210	240	300	309	345
	kW	HP		l/min	800	1600	2500	3000	3500	4000	5000	5150
F 100/250B	55	75	H metres	75	75	74	71.5	69	64.5	51	48	
F 100/250A	75	100		89	89	88.5	87	84	80.5	70.5	69	58

Q = Flow rate H = Total manometric head HS = Suction height

Tolerance of characteristic curves in compliance with EN ISO 9906 App. A.

POS.	COMPONENT	CONSTRUCTION CHARACTERISTICS						
1	PUMP BODY	Cast iron, complete with flanged suction and delivery ports						
2	COUNTERFLANGES	Steel, complete with ISO 228/1 thread						
3a	BODY BACKPLATE	Cast iron						
3b	MOTOR BRACKET	Cast iron						
4	IMPELLER	Brass for F32/160, F32/200, F40/160, F40/200, F50/125, F50/160 Cast iron for F40/250, F50/200, F50/250, F65/125, F65/160, F65/200, F65/250, F80/160, F80/200, F80/250, F100/160, F100/200, F100/250						
5	MOTOR SHAFT	Stainless steel EN 10088-3 - 1.4104						
6	MECHANICAL SEAL	Pump Model		Seal Model	Shaft Diameter	Materials Stationary ring Rotational ring Elastomer		
		F32/160 F50/125	F40/160	FN-20	Ø 20 mm	Graphite	Ceramic NBR	
		F32/200 F50/160	F40/200 F65/125	FN-24	Ø 24 mm	Graphite	Ceramic NBR	
		F50/200 F65/200 F100/160	F65/160 F80/160	FN-32 NU	Ø 32 mm	Graphite	Ceramic NBR	
		F40/250 F65/250 F80/250B F80/250A	F50/250 F80/200 F100/200 F100/250	FN-38 FN-40 FH-45 NU	Ø 38 mm Ø 40 mm Ø 45 mm	Graphite	Ceramic NBR Ceramic NBR Ceramic NBR	
7	BEARINGS	Pump Model			Pump Model			
		Fm32/160C F32/160C F32/160B F40/160C F50/125C	6206 ZZ - C3 / 6204 ZZ		F32/200 F40/200 F50/160 F65/125	6307 ZZ - C3 / 6206 ZZ - C3		
		Fm32/160B F32/160A Fm40/160C F40/160B Fm50/125C F50/125B	6206 ZZ - C3 / 6205 ZZ		F40/250 F50/200 F50/250 F65/160 F65/200 F80/160 F100/160	6310 ZZ - C3 / 6308 ZZ - C3		
		F40/160A F50/125A	6306 ZZ - C3 / 6206 ZZ - C3		F65/250 F80/200 F80/250B F100/200 F80/250A F100/250	6312 ZZ - C3 / 6212 ZZ - C3 6314 ZZ - C3 / 6314 ZZ - C3		
8	CAPACITOR	Pump	Capacitance					
		Single-phase	(230 V or 240 V)					
		Fm32/160C	45 µF 450 VL					
		Fm32/160B	70 µF 450 VL					
		Fm40/160C	70 µF 450 VL					
Fm50/125C	70 µF 450 VL							
9	ELECTRIC MOTOR	Fm: single-phase 230 V - 50 Hz with thermal overload protector built-in to the winding (up to 1.5 kW) F: three-phase 230/400 V - 50 Hz up to 4 kW 400/690 V - 50 Hz from 5.5 to 75 kW ⇒ Pumps fitted with the three-phase motor option offer IE2 (IEC 60034-30) class high performance – Insulation: F class – Protection: IP 55						

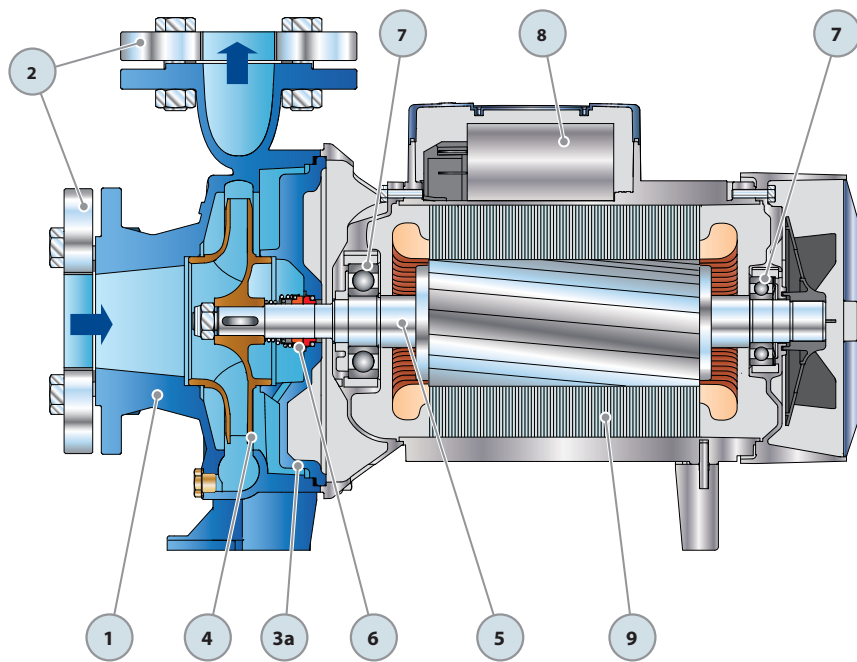

Single-phase version

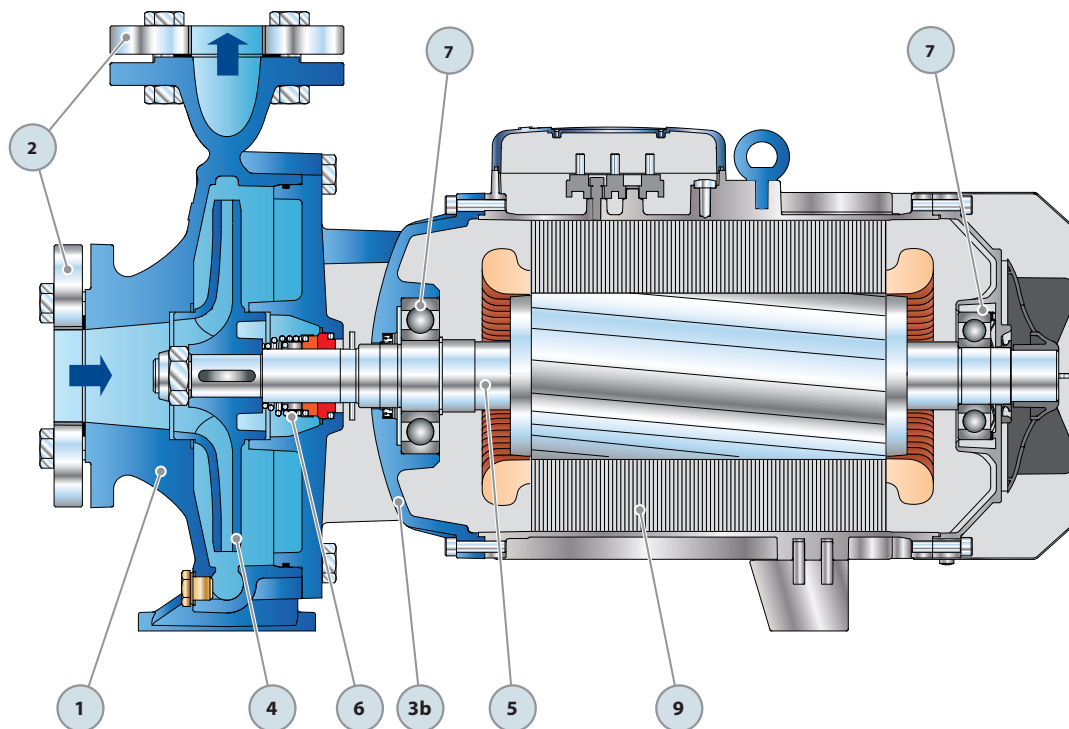

Three-phase version

DIMENSIONS AND WEIGHT

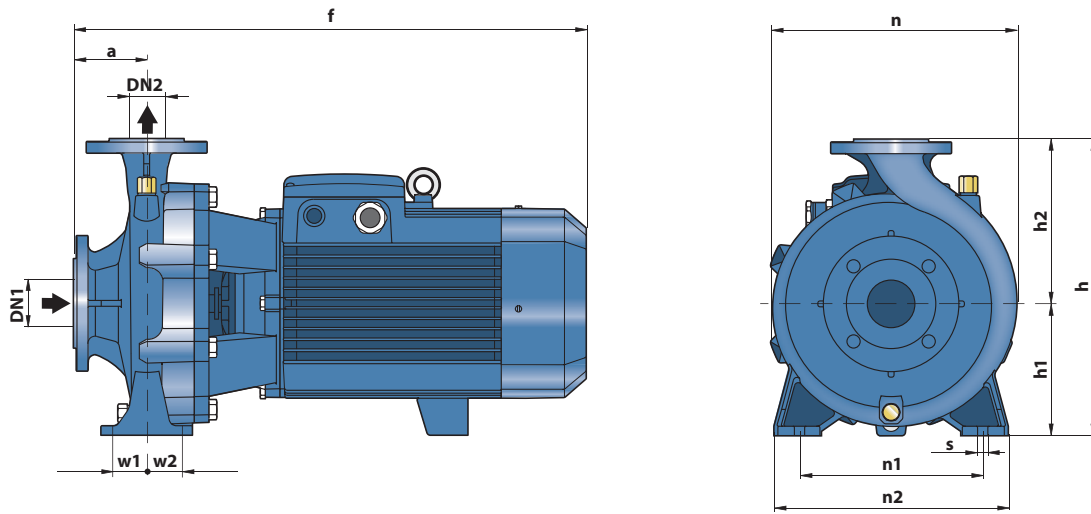

MODEL		PORTS		DIMENSIONS mm											kg *													
Single-phase	Three-phase	DN1	DN2	a	f	h	h1	h2	n	n1	n2	w1	w2	s	1~	3~												
Fm 32/160C	F 32/160C	50	32	80	412	292	132	160	242	190	240	35	35	14	39.2	37.0												
Fm 32/160B	F 32/160B				42.6										38.5													
-	F 32/160A				-										42.6													
-	F 32/200C				-										52.0													
-	F 32/200B				-										57.0													
-	F 32/200A				-										61.0													
-	F 32/200BH				-										47.9													
-	F 32/200AH				-										51.1													
Fm 40/160C	F 40/160C				65										40	80	412	292	132	160	240	212	265	47.5	47.5	14	43.9	40.0
-	F 40/160B																-										44.0	
-	F 40/160A	-	50.1																									
-	F 40/200B	-	61.0																									
-	F 40/200A	-	67.0																									
-	F 40/250C	-	103.0																									
-	F 40/250B	-	109.0																									
-	F 40/250A	-	125.0																									
Fm 50/125C	F 50/125C	65	50	100		431	340	160	180	269	212	265	35	35			14										44.2	40.1
-	F 50/125B					-																					44.1	
-	F 50/125A				-	50.7																						
-	F 50/160C				-	55.0																						
-	F 50/160B				-	60.6																						
-	F 50/160A				-	64.7																						
-	F 50/200C				-	106.0																						
-	F 50/200B				-	128.0																						
-	F 50/200A				-	135.0																						
-	F 50/200AR				-	147.0																						
-	F 50/250D	-	106.0																									
-	F 50/250C	-	113.4																									
-	F 50/250B	-	129.6																									
-	F 50/250A	-	146.0																									
-	F 50/250AR	-	155.0																									
-	F 65/125C	80	65	100	511	340	160	180	291	212	280	47.5	47.5	14	-	62.7												
-	F 65/125B				-										66.8													
-	F 65/125A				-										74.0													
-	F 65/160C				-										100.0													
-	F 65/160B				-										106.5													
-	F 65/160A				-										123.0													
-	F 65/200B				-										128.0													
-	F 65/200A				-										125.0													
-	F 65/200AR				-										153.1													
-	F 80/160D				-										111.5													
-	F 80/160C	100	80	125	652	405	180	225	330	250	320	60	60	18	-	111.5												
-	F 80/160B				-										126.0													
-	F 80/160A				-										143.5													
-	F 100/160C				-										153.0													
-	F 100/160B				-										139.0													
-	F 100/160A				-										153.7													
-	F 100/160A				-										165.0													

(*weight includes counterflanges)

DIMENSIONS AND WEIGHT

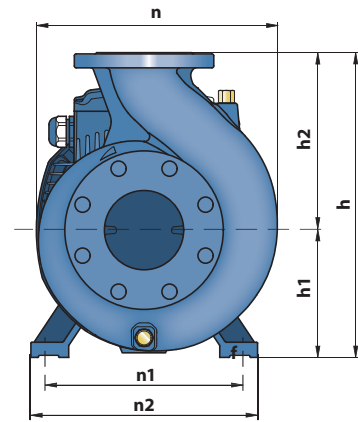
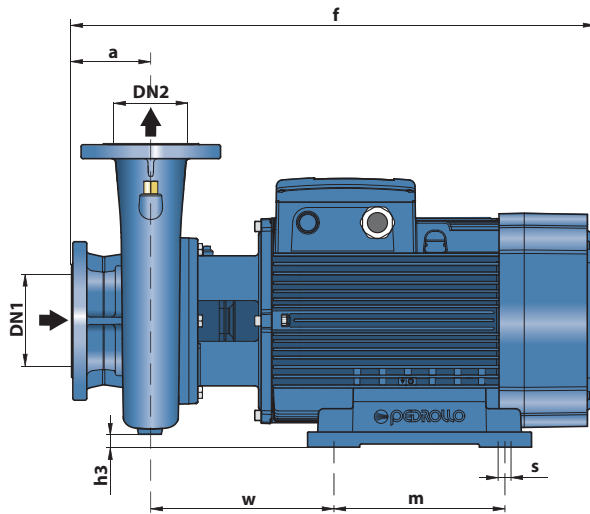

DN FLANGES	D mm	K mm	HOLES	
			N°	Ø (mm)
32	140	100	4	18
40	150	110		
50	165	125		
65	185	145		
80	200	160	8	18
100	220	180		
125	250	210		

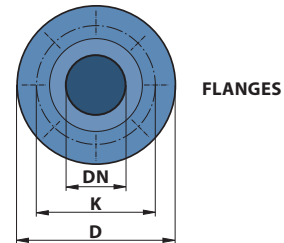

MODEL	PORTS		DIMENSIONS mm											kg *	
	DN1	DN2	a	f	h	h1	h2	h3	n	n1	n2	w	m		s
Three-phase															3~
F 65/250C	80	65	100	796	450	200	250	15	369	318	360	269.5	305	18.5	210.0
F 65/250B				847											230.0
F 65/250A				847											230.0
F 80/200B	100	80	125	824	430	280	25	360	400	490	294	350	24	212.0	
F 80/200A				875										222.5	
F 80/250B				872										245.0	
F 80/250A	125	100	140	1015	620	250	280	55	490	400	490	300	350	24	497.0
F 100/200C				824											208.5
F 100/200B				875											239.0
F 100/200A	125	100	140	875	480	200	280	0	391	318	360	269.5	305	18.5	240.0
F 100/250B				875											498.5
F 100/250A				875											498.5

(*weight includes counterflanges)

COUNTERFLANGES

DN FLANGES	F COUNTERFLANGES	D mm	K mm	HOLES	
				N°	Ø (mm)
32	1¼"	140	100	4	18
40	1½"	150	110		
50	2"	165	125		
65	2½"	185	145		
80	3"	200	160	8	18
100	4"	220	180		
125	5"	250	210		

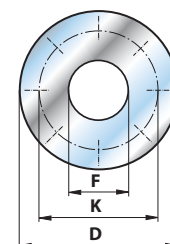

ABSORPTION

MODEL	VOLTAGE (single-phase)	
	230 V	240 V
Single-phase	230 V	240 V
Fm 32/160C	11.0 A	10.0 A
Fm 32/160B	15.0 A	13.8 A
Fm 40/160C	15.0 A	13.8 A
Fm 50/125C	15.0 A	13.8 A

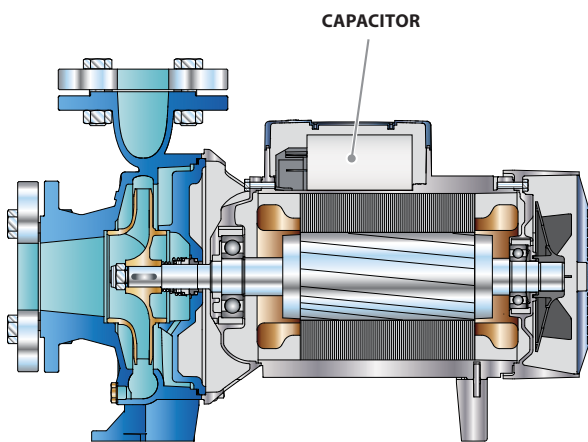

Single-phase version

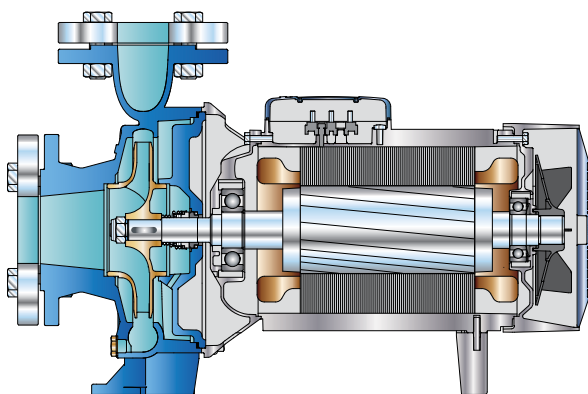

Three-phase version

MODEL	VOLTAGE (three-phase)		
	230÷240 V	400÷415 V	690÷720 V
Three-phase	230÷240 V	400÷415 V	690÷720 V
F 32/160C	7.5 A	4.3 A	2.5 A
F 32/160B	10.0 A	5.8 A	3.4 A
F 32/160A	12.0 A	7.3 A	4.2 A
F 32/200C	17.9 A	10.3 A	5.9 A
F 32/200B	–	11.7 A	6.7 A
F 32/200A	–	14.9 A	8.6 A
F 32/200BH	12.6 A	7.3 A	4.2 A
F 32/200AH	15.4 A	8.9 A	5.1 A
F 40/160C	9.9 A	5.7 A	3.3 A
F 40/160B	12.0 A	6.9 A	4.0 A
F 40/160A	17.2 A	9.9 A	5.7 A
F 40/200B	–	12.6 A	7.3 A
F 40/200A	–	15.6 A	9.0 A
F 40/250C	–	21.0 A	12.1 A
F 40/250B	–	23.5 A	13.6 A
F 40/250A	–	30.5 A	17.6 A
F 50/125C	9.4 A	5.4 A	3.1 A
F 50/125B	12.0 A	6.9 A	4.0 A
F 50/125A	16.3 A	9.4 A	5.4 A
F 50/160C	15.8 A	9.1 A	5.3 A
F 50/160B	–	12.3 A	7.1 A
F 50/160A	–	15.5 A	8.9 A
F 50/200C	–	23 A	13.3 A
F 50/200B	–	29.5 A	17 A
F 50/200A	–	34.5 A	20 A
F 50/200AR	–	41.5 A	24 A
F 50/250D	–	17.2 A	9.9 A
F 50/250C	–	21.0 A	12.0 A
F 50/250B	–	27.0 A	15.6 A
F 50/250A	–	34.0 A	19.6 A
F 50/250AR	–	41.0 A	24.0 A
F 65/125C	17.5 A	10.0 A	5.8 A
F 65/125B	–	12.0 A	7.0 A
F 65/125A	–	16.5 A	9.5 A
F 65/160C	–	19.0 A	11.0 A
F 65/160B	–	23.0 A	13.5 A
F 65/160A	–	27.5 A	16.0 A
F 65/200B	–	30.0 A	17.3 A
F 65/200A	–	35.0 A	20.2 A
F 65/200AR	–	41.0 A	24.0 A
F 65/250C	–	53.0 A	31.0 A
F 65/250B	–	65.0 A	38.0 A
F 65/250A	–	79.0 A	46.0 A
F 80/160D	–	22.0 A	13.0 A
F 80/160C	–	29.0 A	17.0 A
F 80/160B	–	34.5 A	20.0 A
F 80/160A	–	39.0 A	22.5 A
F 80/200B	–	53.0 A	31.0 A
F 80/200A	–	65.0 A	38.0 A
F 80/250B	–	79.0 A	46.0 A
F 80/250A	–	98.0 A	57.0 A
F 100/160C	–	31.0 A	18.0 A
F 100/160B	–	36.0 A	21.0 A
F 100/160A	–	42.0 A	24.0 A
F 100/200C	–	53.0 A	31.0 A
F 100/200B	–	65.0 A	38.0 A
F 100/200A	–	79.0 A	46.0 A
F 100/250B	–	98.0 A	57.0 A
F 100/250A	–	126.0A	73.0 A

PALLETIZATION

MODEL		GROUPAGE				CONTAINER			
Single-phase	Three-phase	n° pumps	H (mm)	kg		n° pumps	H (mm)	kg	
				1~	3~			1~	3~
Fm 32/160C	F 32/160C	18	1430	730	683	24	1860	967	905
Fm 32/160B	F 32/160B	18	1430	781	707	24	1860	1036	936
-	F 32/160A	18	1430	-	784	24	1860	-	1040
-	F 32/200C	12	1535	-	641	16	2000	-	849
-	F 32/200B	12	1535	-	701	16	2000	-	929
-	F 32/200A	12	1535	-	749	16	2000	-	993
-	F 32/200BH	12	1535	-	591	16	2000	-	783
-	F 32/200AH	12	1535	-	629	16	2000	-	833
Fm 40/160C	-	12	1400	509	-	16	1820	673	-
-	F 40/160C	18	1430	-	735	24	1860	-	975
-	F 40/160B	18	1430	-	809	24	1860	-	1073
-	F 40/160A	12	1400	-	617	16	1820	-	817
-	F 40/200B	12	1535	-	749	16	2000	-	993
-	F 40/200A	12	1535	-	821	16	2000	-	1089
-	F 40/250C	6	1200	-	635	9	1730	-	944
-	F 40/250B	6	1200	-	671	9	1730	-	998
-	F 40/250A	6	1200	-	767	9	1730	-	1142
Fm 50/125C	-	18	1430	820	-	24	1860	1088	-
-	F 50/125C	12	1400	-	498	16	1820	-	659
-	F 50/125B	18	1430	-	810	24	1860	-	1075
-	F 50/125A	12	1535	-	625	16	2000	-	828
-	F 50/160C	12	1535	-	677	16	2000	-	897
-	F 50/160B	12	1535	-	744	16	2000	-	987
-	F 50/160A	12	1535	-	793	16	2000	-	1052
-	F 50/200C	6	1200	-	653	9	1730	-	971
-	F 50/200B	6	1200	-	785	9	1730	-	1169
-	F 50/200A	6	1200	-	827	9	1730	-	1232
-	F 50/200AR	6	1380	-	899	9	2000	-	1340
-	F 50/250D	6	1200	-	653	9	1730	-	971
-	F 50/250C	6	1200	-	697	9	1730	-	1037
-	F 50/250B	6	1200	-	794	9	1730	-	1183
-	F 50/250A	6	1200	-	893	9	1730	-	1331
-	F 50/250AR	6	1380	-	947	9	2000	-	1412
-	F 65/125C	12	1535	-	769	16	2000	-	1020
-	F 65/125B	12	1535	-	818	16	2000	-	1085
-	F 65/125A	12	1535	-	905	16	2000	-	1201
-	F 65/160C	6	1200	-	617	9	1730	-	917
-	F 65/160B	6	1200	-	656	9	1730	-	976
-	F 65/160A	6	1200	-	755	9	1730	-	1018
-	F 65/200B	6	1200	-	785	9	1730	-	1169
-	F 65/200A	6	1200	-	767	9	1730	-	1142
-	F 65/200AR	6	1380	-	936	9	2000	-	1395
-	F 65/250C	1	450	-	227	-	-	-	-
-	F 65/250B	1	450	-	247	-	-	-	-
-	F 65/250A	1	450	-	247	-	-	-	-
-	F 80/160D	6	1200	-	686	9	1730	-	1021
-	F 80/160C	6	1380	-	773	9	2000	-	1151
-	F 80/160B	6	1380	-	878	9	2000	-	1309
-	F 80/160A	6	1380	-	935	9	2000	-	1394
-	F 80/200B	1	450	-	229	-	-	-	-
-	F 80/200A	1	450	-	240	-	-	-	-
-	F 80/250B	1	450	-	262	-	-	-	-
-	F 80/250A	1	770	-	514	-	-	-	-
-	F 100/160C	6	1380	-	851	9	2000	-	1256
-	F 100/160B	6	1380	-	939	9	2000	-	1437
-	F 100/160A	6	1380	-	1007	9	2000	-	1502
-	F 100/200C	1	450	-	226	-	-	-	-
-	F 100/200B	1	450	-	256	-	-	-	-
-	F 100/200A	1	450	-	257	-	-	-	-
-	F 100/250B	1	770	-	516	-	-	-	-
-	F 100/250A	1	770	-	516	-	-	-	-

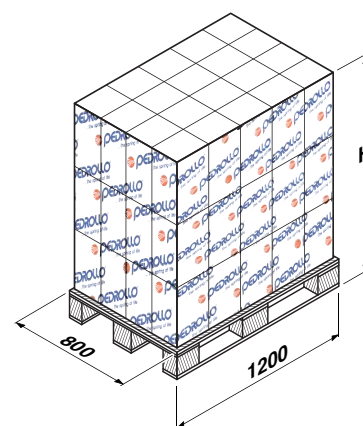



PERFORMANCE RANGE

- Flow rate up to **2200 l/min** (132 m³/h)
- Head up to **38 m**

APPLICATION LIMITS

- Manometric suction lift up to **7 m**
- Liquid temperature between **-10 °C** and **+90 °C**
- Ambient temperature between **-10 °C** and **+40 °C**
- Max. pressure in pump body **10 bar** (PN10)
- Continuous service **S1**

CONSTRUCTION AND SAFETY STANDARDS

EN 60034-1
IEC 60034-1
CEI 2-3



Pump body dimensions in compliance with: **EN 733**

CERTIFICATIONS



INSTALLATION AND USE

- Water supply
- Pressure boosting
- Irrigation
- Water circulation in climatization sets
- Cleaning sets
- Firefighting sets
- Industrial applications
- Agricultural applications

Suitable for use with clean, aggressive liquids that are chemically compatible with the materials from which the pump is made. The pump should be installed in an enclosed environment, or at least sheltered from inclement weather.

OPTIONALS AVAILABLE ON REQUEST

- Special mechanical seal
- Other voltages or 60 Hz frequency
- Compatibility with hotter or colder liquids
- Compatibility with hotter or colder ambients

GUARANTEE

1 year subject to terms and conditions

PERFORMANCE RANGE

50 Hz n= 2900 1/min HS= 0 m

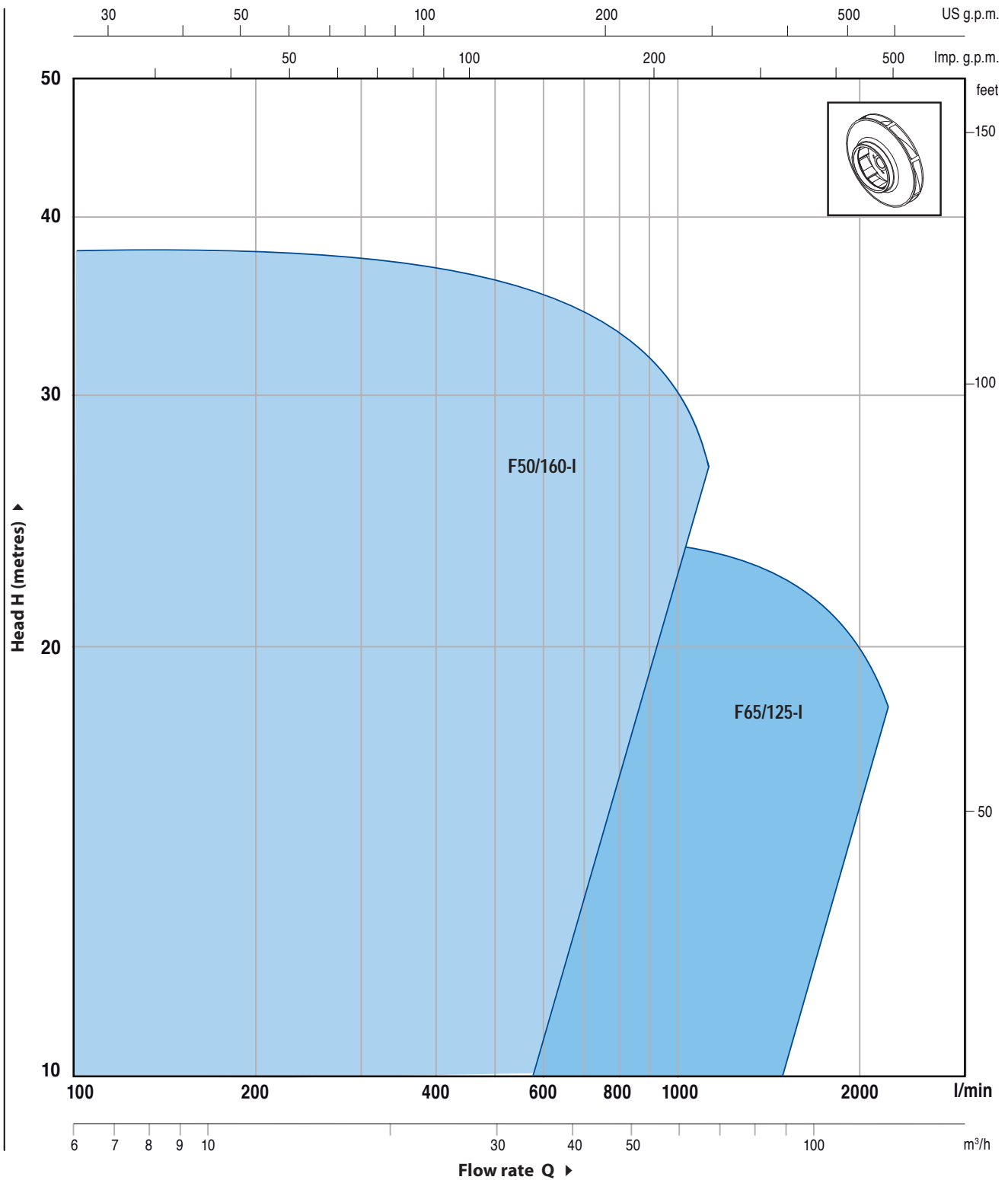

F50/160-I

CHARACTERISTIC CURVES AND PERFORMANCE DATA

50 Hz n= 2900 1/min HS= 0 m

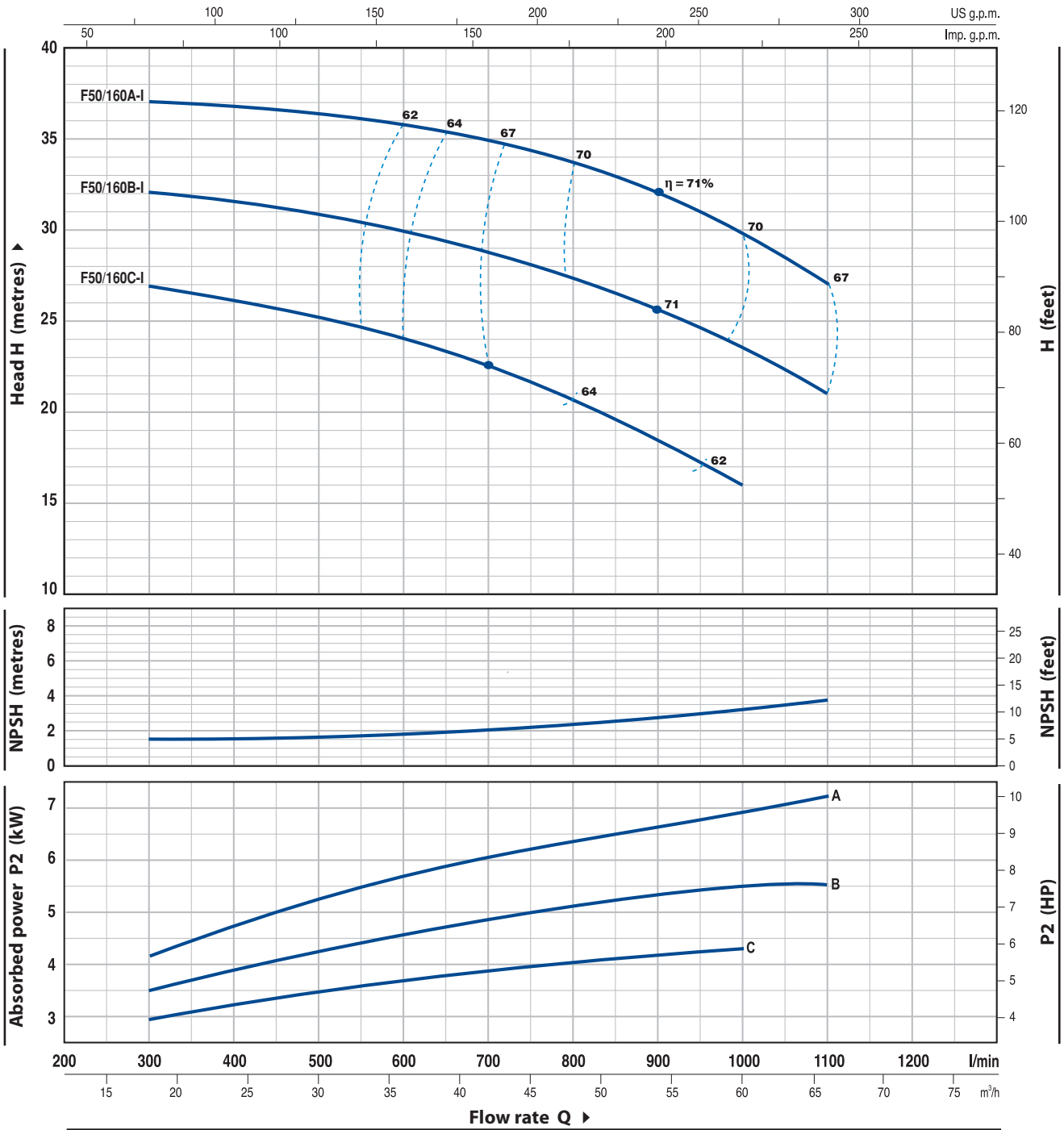

MODEL	POWER		Q	0	18	24	30	36	42	48	54	60	66
	kW	HP		0	300	400	500	600	700	800	900	1000	1100
Three-phase			l/min										
F 50/160C-I	4	5.5	H metres	27	27	26.5	25	24.5	23	20	18.5	16	
F 50/160B-I	5.5	7.5		33	32	31.7	31	30	29	27	26	24	21
F 50/160A-I	7.5	10		38	37	36.8	36.5	36	34	33	32	30	27

Q = Flow rate H = Total manometric head HS = Suction height

Tolerance of characteristic curves in compliance with EN ISO 9906 App. A.

CHARACTERISTIC CURVES AND PERFORMANCE DATA

50 Hz n= 2900 1/min HS= 0 m

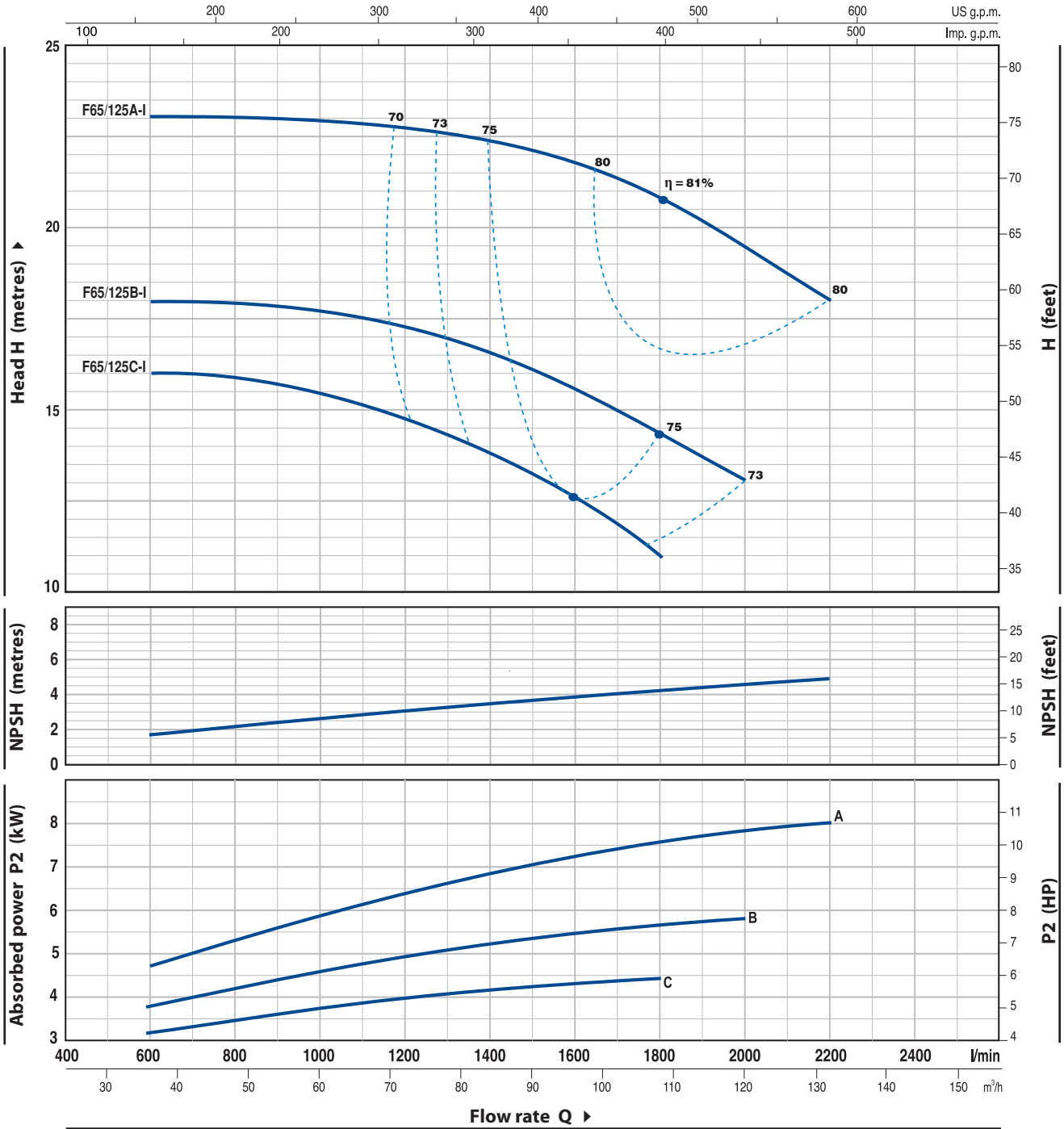

MODEL	POWER		Q	Flow rate												
	kW	HP		m ³ /h	0	36	48	60	72	84	96	108	120	132		
Three-phase			l/min	0	600	800	1000	1200	1400	1600	1800	2000	2200			
F 65/125C-I	4	5.5	H metres	16	16	16	15.5	14.5	13.5	12.5	11					
F 65/125B-I	5.5	7.5		18	18	18	18	17	16.5	15.5	14.5	13				
F 65/125A-I	7.5	10		23	23	23	23	22.5	22.5	22	21	19.5	18			

Q = Flow rate H = Total manometric head HS = Suction height

Tolerance of characteristic curves in compliance with EN ISO 9906 App. A.

POS.	COMPONENT	CONSTRUCTION CHARACTERISTICS					
1	PUMP BODY	Stainless steel AISI 316, complete with flanged suction and delivery ports					
2	BODY BACKPLATE	Stainless steel AISI 316					
4	IMPELLER	Stainless steel AISI 316					
5	MOTOR SHAFT	Stainless steel AISI 316					
6	MECHANICAL SEAL	Pump	Seal	Shaft	Materials		
		<i>Model</i>	<i>Model</i>	<i>Diameter</i>	<i>Stationary ring</i>	<i>Rotational ring</i>	<i>Elastomer</i>
		F50/160-I F65/125-I	FN-24SV	Ø 24 mm	Silicon carbide	Silicon carbide	Viton
7	BEARINGS	Pump	Model				
		F50/160-I F65/125-I	6307 ZZ - C3 / 6206 ZZ - C3				
9	ELECTRIC MOTOR	F: three-phase 230/400 V - 50 Hz for 4 kW. 400/690 V - 50 Hz from 5.5 to 7.5 kW. ➔ Pumps fitted with the three-phase motor option offer IE2 (IEC 60034-30) class high performance – Insulation: F class. – Protection: IP 55.					

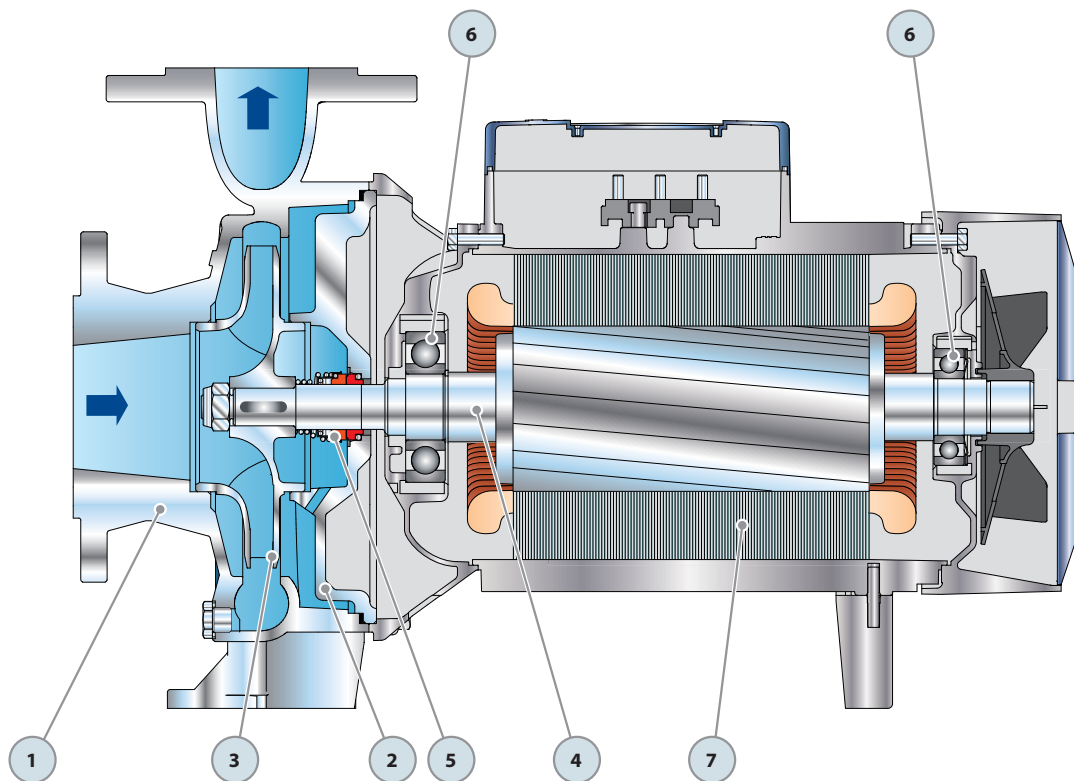

DIMENSIONS AND WEIGHT

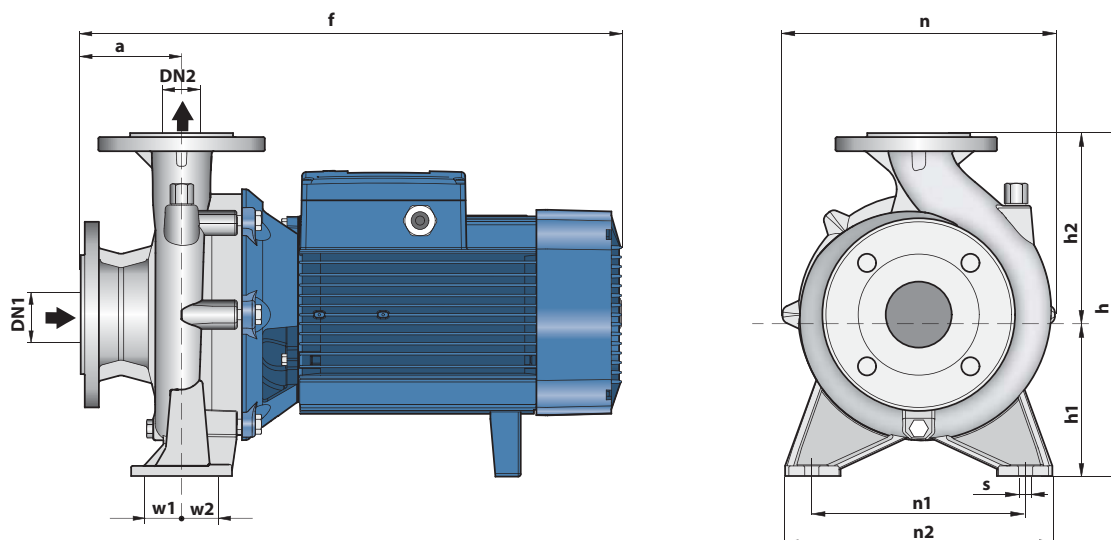

MODEL	PORTS		DIMENSIONS mm											Kg 3~
	DN1	DN2	a	f	h	h1	h2	n	n1	n2	w1	w2	s	
Three-phase														
F 50/160C-I	65	50	100	489	340	160	180	269	212	265	35	35	14	50.2
F 50/160B-I				535										54.0
F 50/160A-I				511										65.5
F 65/125C-I	80	65	100	557	340	160	180	291	212	280	47.5	47.5	14	62.6
F 65/125B-I				557										67.7
F 65/125A-I				557										72.9

ABSORPTION

MODEL	VOLTAGE (three-phase)		
	230÷240 V	400÷415 V	690÷720 V
Three-phase			
F 50/160C-I	15.8 A	9.1 A	5.3 A
F 50/160B-I	-	12.3 A	7.1 A
F 50/160A-I	-	15.5 A	8.9 A
F 65/125C-I	17.5 A	10.0 A	5.8 A
F 65/125B-I	-	12.0 A	7.0 A
F 65/125A-I	-	16.5 A	9.5 A

PALLETIZATION

MODEL	GROUPAGE			CONTAINER		
	n° pumps	H (mm)	kg 3~	n° pumps	H (mm)	kg 3~
Threw						
F 50/160C-I	12	1535	619	16	2000	820
F 50/160B-I	12	1535	665	16	2000	881
F 50/160A-I	12	1535	802	16	2000	1064
F 65/125C-I	12	1535	768	16	2000	1018
F 65/125B-I	12	1535	829	16	2000	1100
F 65/125A-I	12	1535	891	16	2000	1183

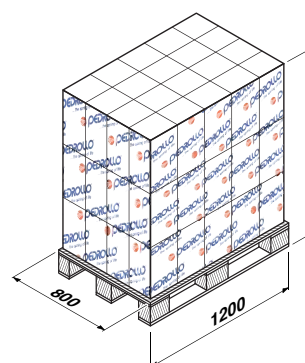



PERFORMANCE RANGE

- Flow rate up to **6000 l/min** (360 m³/h)
- Head up to **95 m**

APPLICATION LIMITS

- Manometric suction lift up to **7 m**
- Liquid temperature between **-10 °C** and **+90 °C**
- Max. pressure in pump body **10 bar** (PN10)

CONSTRUCTION AND SAFETY STANDARDS

EN 733



CERTIFICATIONS



INSTALLATION AND USE

- Water supply
- Pressure boosting
- Irrigation
- Water circulation in climatization sets
- Cleaning sets
- Firefighting sets
- Industrial applications
- Agricultural applications

OPTIONALS AVAILABLE ON REQUEST

- Special mechanical seal
- Counterflange
- Pumps compatible with 60 Hz motors
- Compatibility with hotter or colder liquids
- Compatibility with hotter or colder ambients

GUARANTEE

1 year subject to terms and conditions

DIMENSIONS AND WEIGHT

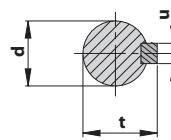
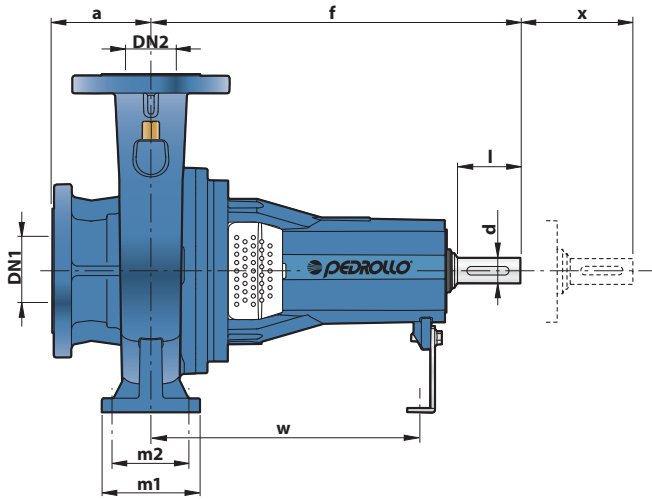

SHAFT DIMENSIONS

mm		
d	u	t
24 k6	8	27
32 k6	10	35

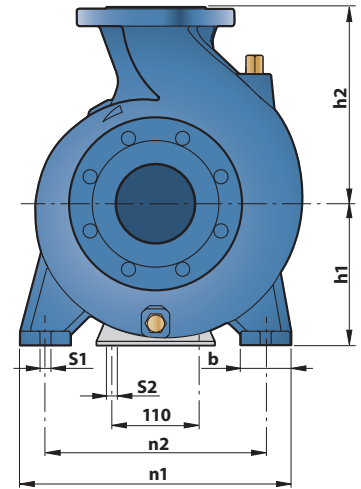

DN FLANGES	D mm	K mm	HOLES	
			N°	Ø (mm)
32	140	100	4	18
40	150	110		
50	165	125		
65	185	145		
80	200	160	8	18
100	220	180		
125	250	210		

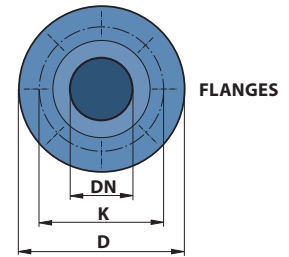

MODEL	PORTS		DIMENSIONS mm														kg	
	DN1	DN2	a	f	h1	h2	b	m1	m2	n1	n2	s1	s2	w	x	d		l
FG 32/160	50	32	80	360	132	160	50	100	95	70	240	190	14	260	100	24	50	30.9
FG 32/200					160	180	55	245			32.0							
FG 32/200H					160	180	55	245	31.4									
FG 40/160	65	40	100	360	132	160	50	100	100	70	240		14	260	100	24	50	29.0
FG 40/200					160	180	55	265			212	35.6						
FG 40/250					180	225	65	125	95	320	250	44.4						
FG 50/125	65	50	100	360	132	160	50	100	100	70	240	190	14	260	100	24	50	28.9
FG 50/160					160	180	55	265			212	32.8						
FG 50/200					160	200	50					41.3						
FG 50/250	180	225	65	125	95	320	250	46.6										
FG 65/125	80	65	100	360	160	180	65	125	125	95	280	212	14	260	100	24	50	40.1
FG 65/160					160	200	65											41.4
FG 65/200					180	225	65	320	250	46.5								
FG 65/250	470	200	250	80	160	120	360	280	18	340		32	80	67.7				
FG 80/160	100	80	125	360	180	225	65	125	125	95	320	250	14	260	140	24	50	45.2
FG 80/200					180	250	65	345			280	61.4						
FG 80/250					470	200	280	80	160	120	400	315						18
FG 100/160	125	100	140	360	200	280	80	160	160	120	360	280	18	260	140	24	50	52.8
FG 100/200					200	280	80	400			315	74.3						
FG 100/250					225	280	80	400	315	84.0								

PERFORMANCE RANGE

HS= 0 m

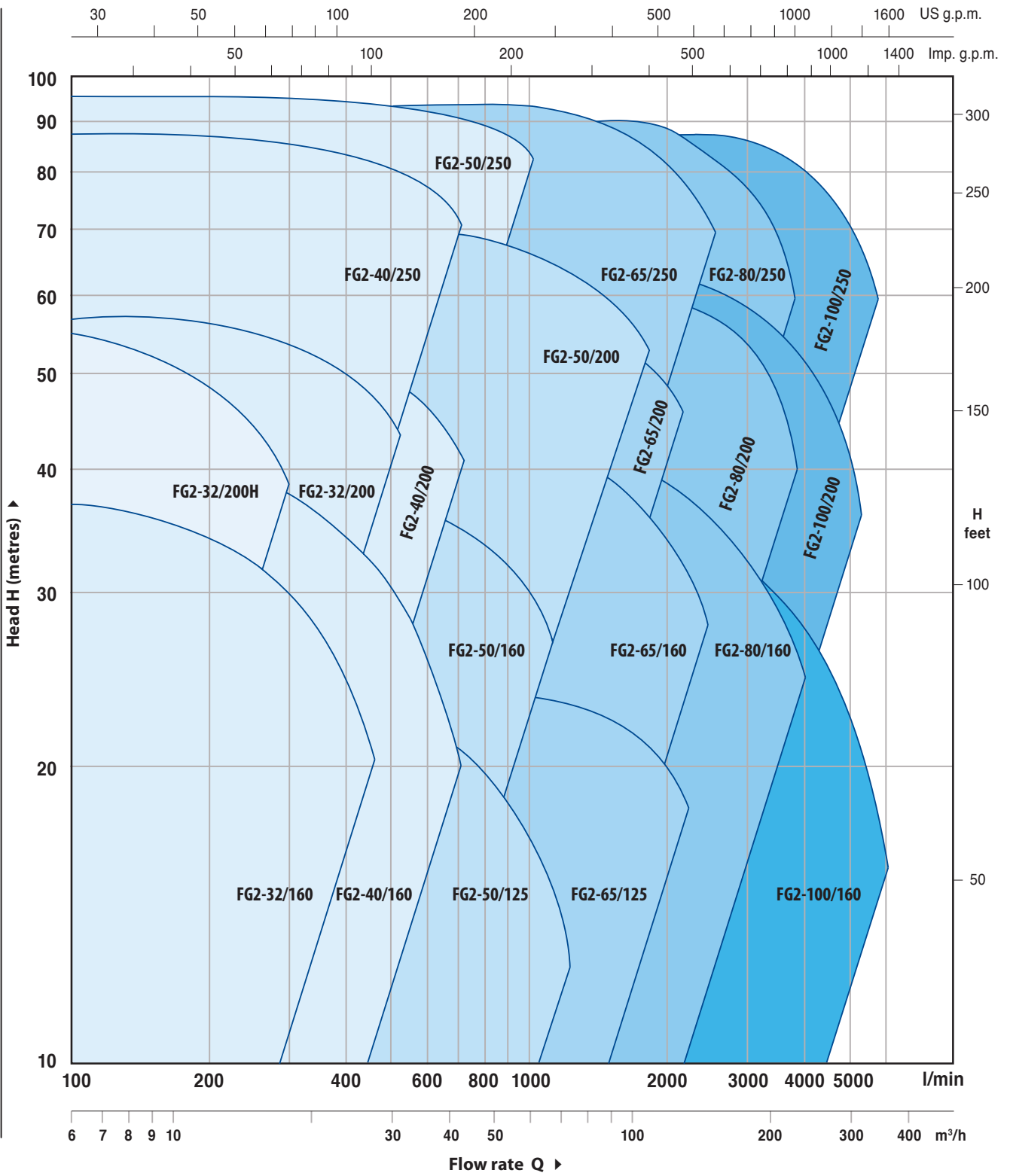

PERFORMANCE DATA
n= 2900 1/min HS= 0 m

MODEL pump	MOTOR PAIRING		PERFORMANCE	
	kW	HP	Q l/min	H metres
FG2 32/160C	1.5	2	100 ÷ 350	24 ÷ 14
FG2 32/160B	2.2	3	100 ÷ 400	30 ÷ 17
FG2 32/160A	3	4	100 ÷ 450	37 ÷ 24
FG2 32/200C	4	5.5	100 ÷ 450	44 ÷ 31.5
FG2 32/200B	5.5	7.5	100 ÷ 500	51 ÷ 36
FG2 32/200A	7.5	10	100 ÷ 500	57 ÷ 44
FG2 32/200BH	3	4	100 ÷ 300	45 ÷ 37
FG2 32/200AH	4	5.5	100 ÷ 320	55 ÷ 44
FG2 40/160C	2.2	3	100 ÷ 600	27 ÷ 14
FG2 40/160B	3	4	100 ÷ 600	32 ÷ 20
FG2 40/160A	4	5.5	100 ÷ 700	38 ÷ 20
FG2 40/200B	5.5	7.5	100 ÷ 700	47 ÷ 28
FG2 40/200A	7.5	10	100 ÷ 700	55 ÷ 41
FG2 40/250C	9.2	12.5	100 ÷ 700	64 ÷ 47
FG2 40/250B	11	15	100 ÷ 700	71 ÷ 55
FG2 40/250A	15	20	100 ÷ 700	88 ÷ 72
FG2 50/125C	2.2	3	300 ÷ 1200	17.5 ÷ 6
FG2 50/125B	3	4	300 ÷ 1200	20.7 ÷ 9
FG2 50/125A	4	5.5	300 ÷ 1200	23.5 ÷ 13
FG2 50/160C	4	5.5	300 ÷ 1000	27 ÷ 16
FG2 50/160B	5.5	7.5	300 ÷ 1100	32 ÷ 21
FG2 50/160A	7.5	10	300 ÷ 1100	37 ÷ 27
FG2 50/200C	11	15	400 ÷ 1700	44 ÷ 30
FG2 50/200B	15	20	400 ÷ 1700	52 ÷ 38
FG2 50/200A	18.5	25	400 ÷ 1800	61 ÷ 45
FG2 50/200AR	22	30	400 ÷ 1800	69 ÷ 53
FG2 50/250D	9.2	12.5	300 ÷ 900	51 ÷ 32
FG2 50/250C	11	15	300 ÷ 900	59 ÷ 42
FG2 50/250B	15	20	300 ÷ 1000	72 ÷ 59
FG2 50/250A	18.5	25	300 ÷ 1000	85 ÷ 73
FG2 50/250AR	22	30	300 ÷ 1000	95 ÷ 83
FG2 65/125C	4	5.5	600 ÷ 1800	16 ÷ 11
FG2 65/125B	5.5	7.5	600 ÷ 2000	18 ÷ 13
FG2 65/125A	7.5	10	600 ÷ 2200	23 ÷ 18
FG2 65/160C	9.2	12.5	600 ÷ 2200	32 ÷ 22
FG2 65/160B	11	15	600 ÷ 2400	36.5 ÷ 23
FG2 65/160A	15	20	600 ÷ 2400	40.5 ÷ 28
FG2 65/200B	15	20	400 ÷ 2000	45 ÷ 35.5
FG2 65/200A	18.5	25	400 ÷ 2100	51 ÷ 40
FG2 65/200AR	22	30	400 ÷ 2100	57 ÷ 46
FG2 65/250C	30	40	400 ÷ 2350	76 ÷ 53
FG2 65/250B	37	50	400 ÷ 2500	87 ÷ 62
FG2 65/250A	45	60	400 ÷ 2600	94.5 ÷ 68

MODEL pump	MOTOR PAIRING		PERFORMANCE	
	kW	HP	Q l/min	H metres
FG2 80/160D	11	15	500 ÷ 4000	25 ÷ 10
FG2 80/160C	15	20	500 ÷ 4000	30 ÷ 15
FG2 80/160B	18.5	25	500 ÷ 4000	35 ÷ 20
FG2 80/160A	22	30	500 ÷ 4000	40 ÷ 25
FG2 80/200B	30	40	500 ÷ 3650	56 ÷ 34.5
FG2 80/200A	37	50	500 ÷ 3900	62 ÷ 40
FG2 80/250B	45	60	600 ÷ 3600	77 ÷ 54
FG2 80/250A	55	75	600 ÷ 3900	88.5 ÷ 60
FG2 100/160C	15	20	1000 ÷ 5000	28 ÷ 12
FG2 100/160B	18.5	25	1000 ÷ 5500	32 ÷ 13
FG2 100/160A	22	30	1000 ÷ 6000	35 ÷ 15
FG2 100/200C	30	40	800 ÷ 4650	51 ÷ 28
FG2 100/200B	37	50	800 ÷ 4900	57 ÷ 33
FG2 100/200A	45	60	800 ÷ 5250	63 ÷ 38
FG2 100/250B	55	75	800 ÷ 5150	73 ÷ 48
FG2 100/250A	75	100	800 ÷ 5750	88 ÷ 58

PERFORMANCE RANGE

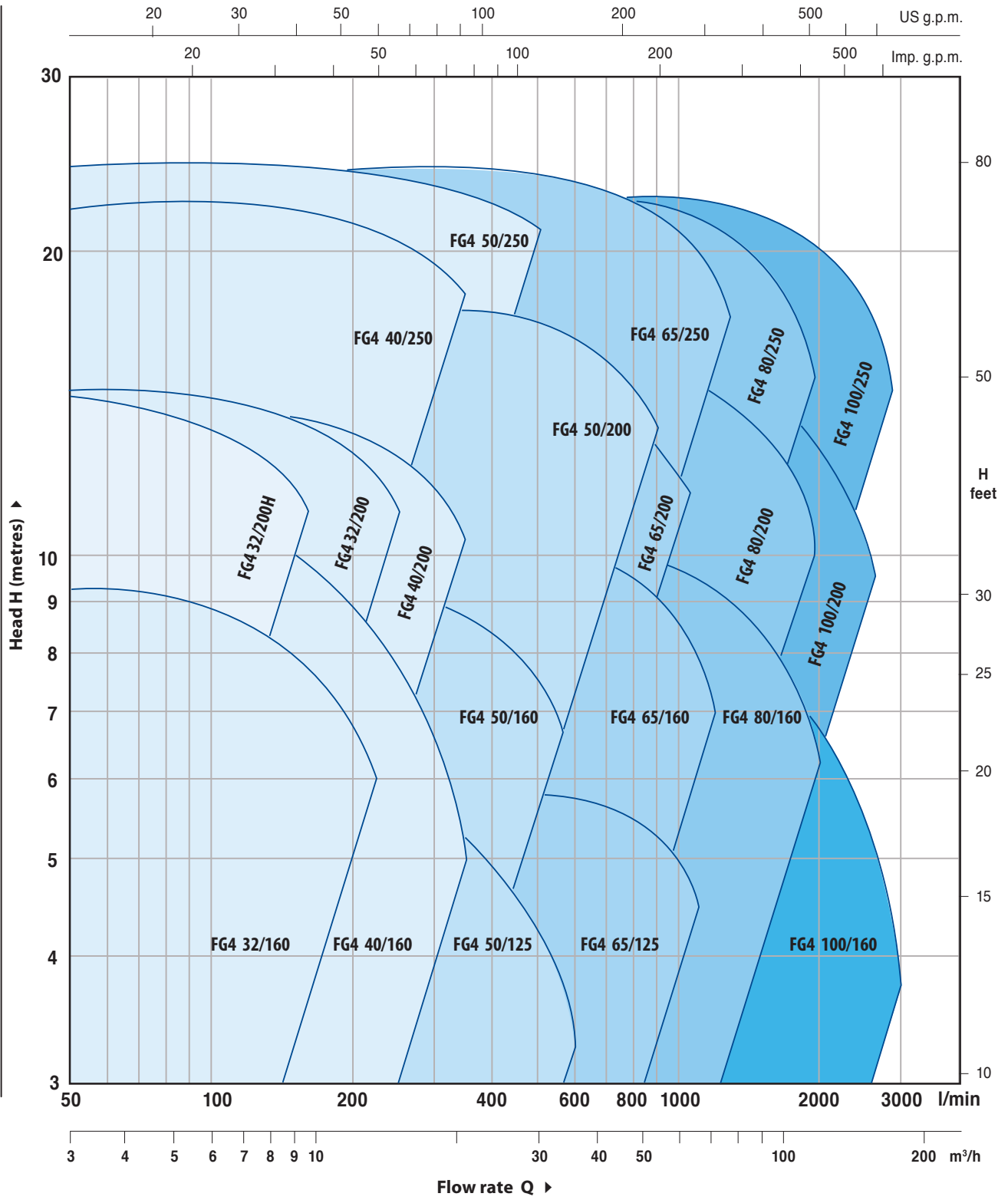

PERFORMANCE DATA
n= 1450 1/min HS= 0 m

MODEL pump	MOTOR PAIRING		PERFORMANCE	
	kW	HP	Q l/min	H metres
FG4 32/160C	0.25	0.33	50 ÷ 175	6 ÷ 3.5
FG4 32/160B	0.37	0.5	50 ÷ 200	7.5 ÷ 4
FG4 32/160A	0.37	0.5	50 ÷ 225	9 ÷ 6
FG4 32/200C	0.55	0.75	50 ÷ 225	11 ÷ 8
FG4 32/200B	0.75	1	50 ÷ 250	12.5 ÷ 9
FG4 32/200A	1.1	1.5	50 ÷ 250	14 ÷ 11
FG4 32/200BH	0.55	0.75	50 ÷ 150	11 ÷ 9
FG4 32/200AH	0.55	0.75	50 ÷ 160	13.5 ÷ 11
FG4 40/160C	0.37	0.5	50 ÷ 300	6.5 ÷ 3.5
FG4 40/160B	0.37	0.5	50 ÷ 300	8 ÷ 5
FG4 40/160A	0.55	0.75	50 ÷ 350	9.5 ÷ 5
FG4 40/200B	0.75	1	50 ÷ 350	11.5 ÷ 7
FG4 40/200A	1.1	1.5	50 ÷ 350	13.5 ÷ 10
FG4 40/250C	1.1	1.5	50 ÷ 350	16 ÷ 11.5
FG4 40/250B	1.5	2	50 ÷ 350	17.5 ÷ 13.5
FG4 40/250A	2.2	3	50 ÷ 350	22 ÷ 18
FG4 50/125C	0.37	0.5	150 ÷ 600	4 ÷ 1.5
FG4 50/125B	0.55	0.75	150 ÷ 600	5 ÷ 2
FG4 50/125A	0.55	0.75	150 ÷ 600	6 ÷ 3
FG4 50/160C	0.55	0.75	150 ÷ 500	7 ÷ 4
FG4 50/160B	0.75	1	150 ÷ 550	8 ÷ 5
FG4 50/160A	1.1	1.5	150 ÷ 550	9 ÷ 7
FG4 50/200C	1.5	2	200 ÷ 850	11 ÷ 7.5
FG4 50/200B	2.2	3	200 ÷ 850	13 ÷ 9.5
FG4 50/200A	2.2	3	200 ÷ 900	15 ÷ 11
FG4 50/200AR	3	4	200 ÷ 900	17 ÷ 13
FG4 50/250D	1.1	1.5	150 ÷ 450	12.5 ÷ 8
FG4 50/250C	1.5	2	150 ÷ 450	14.5 ÷ 10.5
FG4 50/250B	2.2	3	150 ÷ 500	18 ÷ 14.5
FG4 50/250A	2.2	3	150 ÷ 500	21 ÷ 18
FG4 50/250AR	3	4	150 ÷ 500	24 ÷ 21
FG4 65/125C	0.55	0.75	300 ÷ 900	4 ÷ 2.5
FG4 65/125B	0.75	1	300 ÷ 1000	4.5 ÷ 3
FG4 65/125A	1.1	1.5	300 ÷ 1100	5.5 ÷ 4.5
FG4 65/160C	1.1	1.5	300 ÷ 1100	8 ÷ 5.5
FG4 65/160B	1.5	2	300 ÷ 1200	9 ÷ 5.5
FG4 65/160A	2.2	3	300 ÷ 1200	10 ÷ 7
FG4 65/200B	2.2	3	200 ÷ 1000	11 ÷ 9
FG4 65/200A	2.2	3	200 ÷ 1050	12.5 ÷ 10
FG4 65/200AR	3	4	200 ÷ 1050	14.3 ÷ 11.5
FG4 65/250C	3	4	200 ÷ 1175	19 ÷ 13
FG4 65/250B	4	5.5	200 ÷ 1250	21.5 ÷ 15.5
FG4 65/250A	5.5	7.5	200 ÷ 1300	23.5 ÷ 17

MODEL pump	MOTOR PAIRING		PERFORMANCE	
	kW	HP	Q l/min	H metres
FG4 80/160D	1.5	2	250 ÷ 2000	6 ÷ 2.5
FG4 80/160C	2.2	3	250 ÷ 2000	7.5 ÷ 3.5
FG4 80/160B	2.2	3	250 ÷ 2000	8.5 ÷ 5
FG4 80/160A	3	4	250 ÷ 2000	10 ÷ 6
FG4 80/200B	4	5.5	250 ÷ 1825	14 ÷ 8.5
FG4 80/200A	5.5	7.5	250 ÷ 1950	15.5 ÷ 10
FG4 80/250B	5.5	7.5	300 ÷ 1800	19 ÷ 13.5
FG4 80/250A	7.5	10	300 ÷ 1950	22 ÷ 15
FG4 100/160C	2.2	3	500 ÷ 2500	7 ÷ 3
FG4 100/160B	3	4	500 ÷ 2750	8 ÷ 3
FG4 100/160A	3	4	500 ÷ 3000	8.5 ÷ 3.5
FG4 100/200C	4	5.5	400 ÷ 2325	12.5 ÷ 7
FG4 100/200B	5.5	7.5	400 ÷ 2450	14 ÷ 8
FG4 100/200A	5.5	7.5	400 ÷ 2625	15.5 ÷ 9.5
FG4 100/250B	7.5	10	400 ÷ 2575	18.5 ÷ 12
FG4 100/250A	9.2	12.5	400 ÷ 2875	22 ÷ 14.5

BETTY

Portable self-priming pumps



BETTY 60-65



BETTY X



BETTYNOX

PERFORMANCE RANGE

- Flow rate up to **50 l/min** (3 m³/h)
- Head up to **55 m**

APPLICATION LIMITS

- Manometric suction lift up to **9 m**
- Ambient temperature up to **+40 °C**
- Max. working pressure **6 bar**
- Continuous service **S1**

PERFORMANCE AND CONSTRUCTION CHARACTERISTICS

MODEL	PUMP	Q	H
		l/min	metres
BETTY 60	PKSm 60	5÷40	38÷5
BETTY 65	PKSm 65	5÷50	50÷8
BETTY 1X	JSWm 1CX	5÷50	32÷13
BETTY 2X	JSWm 1BX	5÷50	36÷15
BETTY 3X	JSWm 1AX	5÷50	42÷19
BETTYNOX 1	JCRm 1C	5÷50	32÷13
BETTYNOX 2	JCRm 1B	5÷50	36÷15
BETTYNOX 3	JCRm 1A	5÷50	42÷19

- ➔ The **BETTY** series portable pumps come complete with:
- a handle
 - **Ø 20 mm** hose attachments
 - **1.5 m** long power cable with Schuko plug

SAFETY STANDARDS

EN 60335-1
IEC 60335-1
CEI 61-150



CERTIFICATIONS



INSTALLATION AND USE

Suitable for use in gardening, horticultural, cleaning and hobby activities, they are suitable for use with any liquid that is compatible with the materials from which they are made.

OPTIONALS AVAILABLE ON REQUEST

- Other voltages or 60 Hz frequency

GUARANTEE

1 year subject to terms and conditions

DIMENSIONS AND WEIGHT

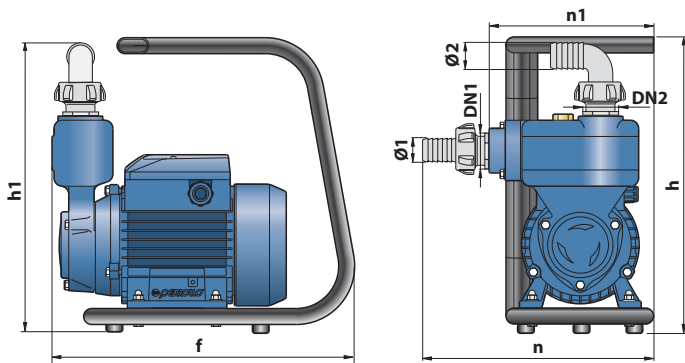

MODEL	PORTS		DIMENSIONS mm						kg	
	DN1	DN2	Ø1	Ø2	f	h	h1	n		n1
Single-phase										
BETTY 60	1"	1"	20	20	270	273	267	220	160	7.9
BETTY 65										9.5

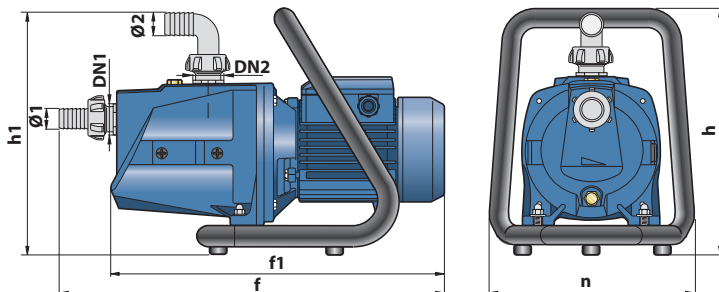

MODEL	PORTS		DIMENSIONS mm						Kg	
	DN1	DN2	Ø1	Ø2	f	f1	h	h1		n
Single-phase										
BETTY 1X					439	379				10.0
BETTY 2X	1"	1"	20	20			260	255	230	10.7
BETTY 3X					447	387				10.9

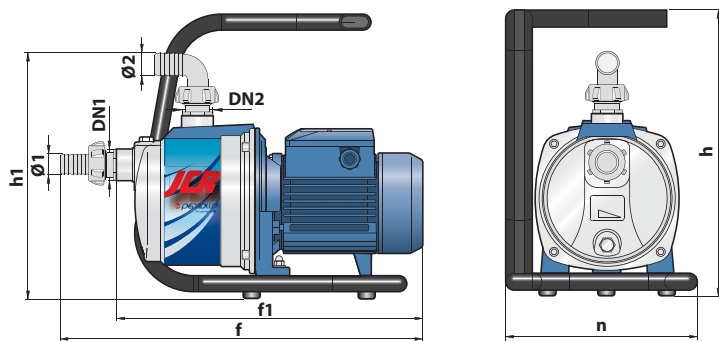

MODEL	PORTS		DIMENSIONS mm						kg	
	DN1	DN2	Ø1	Ø2	f	f1	h	h1		n
Single-phase										
BETTYNOX 1					405	345				7.9
BETTYNOX 2	1"	1"	20	20			270	260	198	8.0
BETTYNOX 3					413	353				9.2

PALLETIZATION

MODEL	GROUPAGE			CONTAINER		
	n° pumps	H (mm)	kg 1~	n° pumps	H (mm)	kg 1~
Single-phase						
BETTY 60	30	1265	254	50	2015	412
BETTY 65	30	1265	302	50	2015	492
BETTY 1X	30	1265	317	50	2015	517
BETTY 2X	30	1265	338	50	2015	552
BETTY 3X	30	1265	344	50	2015	562
BETTYNOX 1	30	1265	254	50	2015	412
BETTYNOX 2	30	1265	257	50	2015	417
BETTYNOX 3	30	1265	293	50	2015	477

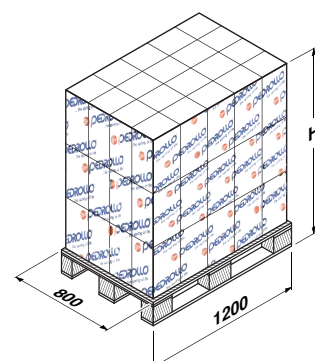

TOP MULTI

Submersible multi-impeller pumps



PERFORMANCE RANGE

- Flow rate up to **120 l/min** (7.2 m³/h)
- Head up to **42 m**

APPLICATION LIMITS

- **10 m** maximum immersion depth
- Maximum liquid temperature **+40 °C**
- Passage of suspended solids up to **Ø 1.3 mm**
- Suction down to **22 mm** above ground level
- Continuous service **S1**

CONSTRUCTION AND SAFETY STANDARDS

Complete with :
– **10 m** long power cable
– float switch

EN 60335-1
IEC 60335-1
CEI 61-150

EN 60034-1
IEC 60034-1
CEI 2-3



CERTIFICATIONS



INSTALLATION AND USE

Suitable for use with clean water and liquids that are not chemically aggressive towards the materials from which the pump is made. As a result of their high efficiency and reliability they are suitable for use in applications such as domestic water supply from reservoirs, tanks or relatively deep wells, for drawing rain water from cisterns to water gardens or for use in irrigation systems, etc.

PATENTS - TRADE MARKS - MODELS

- TOP MULTI® is a registered trade mark
- Registered Community Design n° e-00050929-F

OPTIONALS AVAILABLE ON REQUEST

- Pumps without float switch
- Other voltages or 60 Hz frequency

GUARANTEE

1 year subject to terms and conditions

CHARACTERISTIC CURVES AND PERFORMANCE DATA

50 Hz n= 2900 1/min

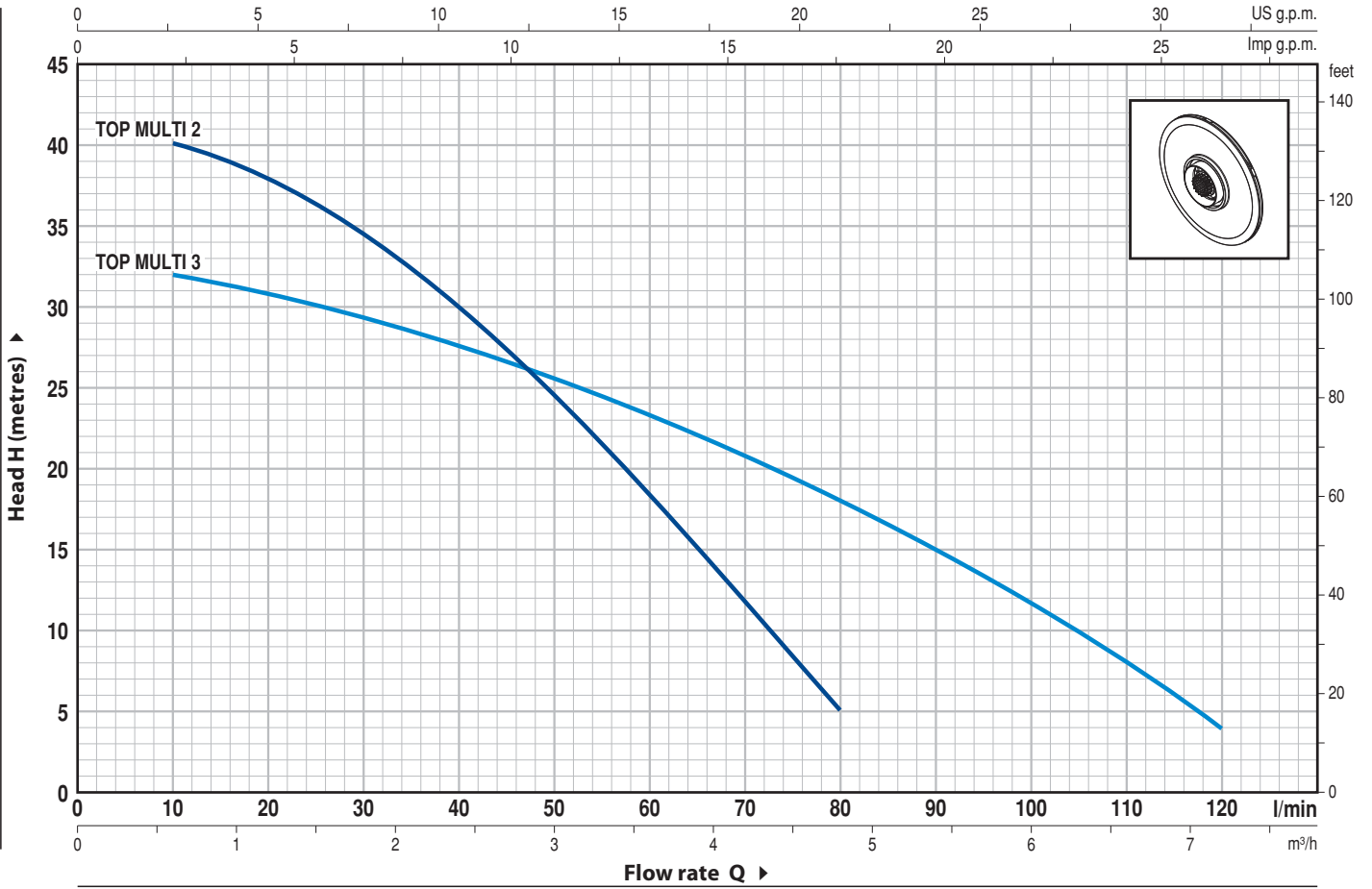

MODEL	POWER		Q	Flow rate Q															
	kW	HP		0	0.6	1.2	1.8	2.4	3.0	3.6	4.2	4.8	5.4	6.0	6.6	7.2			
Single-phase			Q	0	10	20	30	40	50	60	70	80	90	100	110	120			
TOP MULTI 2	0.55	0.75	H metres	42	40	38	34	30	24	18	11.5	5							
TOP MULTI 3	0.55	0.75	H metres	33	32	31	29.5	28	25.5	23	20.5	18	15	12	8	4			

Q = Flow rate H = Total manometric head

Tolerance of characteristic curves in compliance with EN ISO 9906 App. A.

POS.	COMPONENT	CONSTRUCTION CHARACTERISTICS				
1	DELIVERY BODY	Glass fibre reinforced technopolymer, complete with threaded delivery port in compliance with ISO 228/1				
2	PUMP BODY AND SUCTION FILTER	Glass fibre reinforced technopolymer				
3	MOTOR SLEEVE	Stainless steel AISI 304				
4	IMPELLERS	Noryl GFN2V				
5	DIFFUSERS	Noryl GFN2V complete with anti-wear rings				
6	MOTOR SHAFT	Stainless steel EN 10088-3 - 1.4104				
7	TWO MECHANICAL SEALS SEPARATED BY AN OIL CHAMBER					
	<i>Seal</i>	<i>Shaft</i>	<i>Position</i>	<i>Materials</i>		
	<i>Model</i>	<i>Diameter</i>		<i>Stationary ring</i>	<i>Rotational ring</i>	<i>Elastomer</i>
	AR-13R	Ø 13 mm	Motor side	Ceramic	Graphite	NBR
	AR-12R SIC	Ø 12 mm	Pump side	Ceramic	Silicon carbide	NBR
8	BEARINGS	6202 ZZ - C3 / 6201 ZZ				
9	CAPACITOR					
	<i>Capacitance</i>					
	(230 V or 240 V)	(110 V)				
	12.5 µF 450 VL	30 µF 250 VL				
10	ELECTRIC MOTOR	TOP MULTI: single-phase 230 V - 50 Hz with built-in overload protector.				
		– Insulation: F class.				
		– Protection: IP 68.				
11	POWER CABLE	⇒ 10 metre long "H07 RN-F" cable with Schuko plug				
12	FLOAT SWITCH					
13	HOSE CONNECTOR WITH UNION	Ø 35 mm hose connection				
14	PIPE COUPLING	Threaded 1¼" in compliance with ISO 228/1, complete with clapet valve				

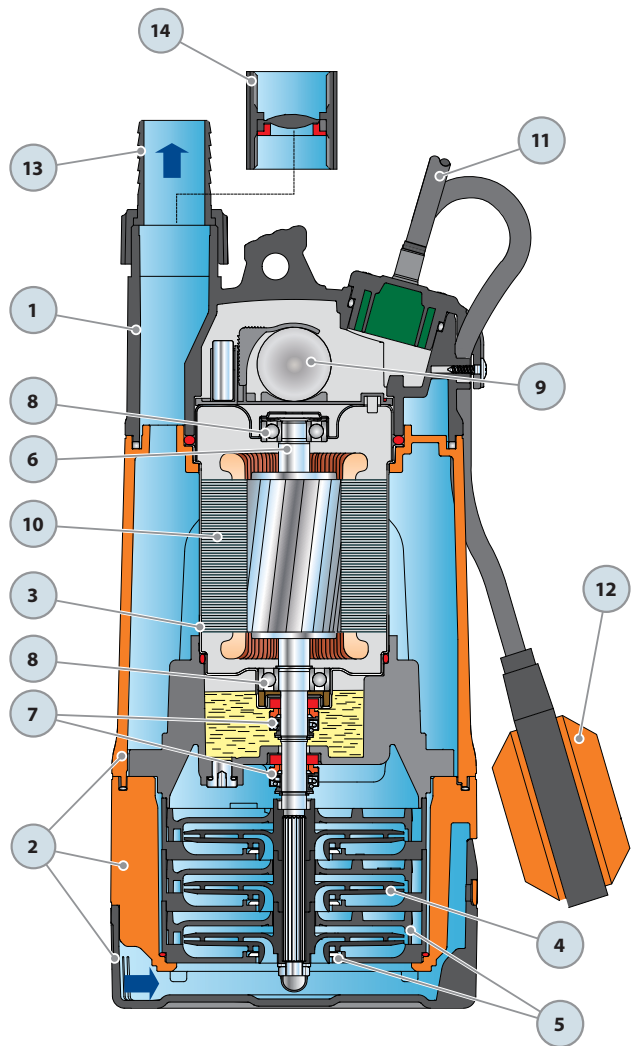

DIMENSIONS AND WEIGHT

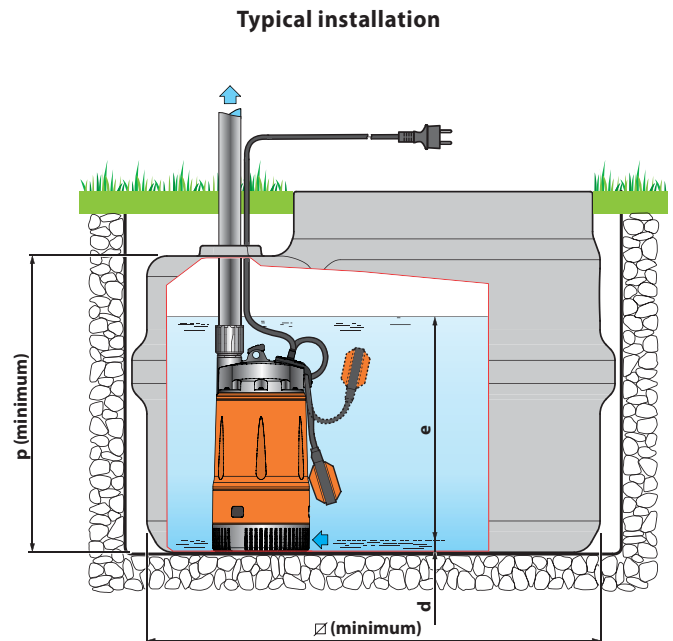
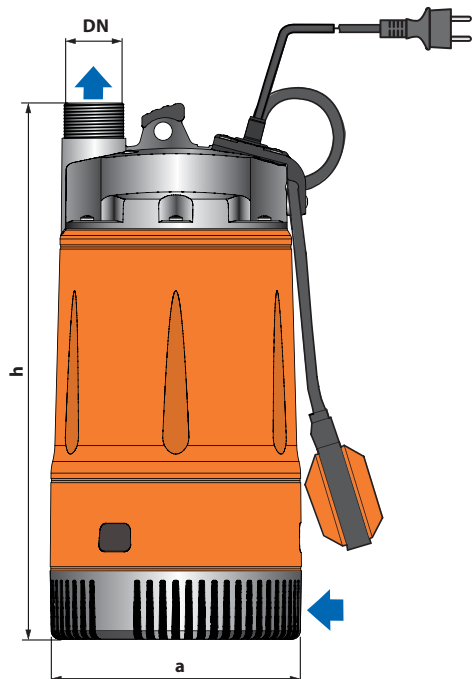

MODEL	PORT DN	N° STAGES	DIMENSIONS mm						Kg
			a	h	d	e	p	Ø	
Single-phase	1 1/4"	3	178	380	22	variable	500	500	9.4
TOP MULTI 2									
TOP MULTI 3									

ABSORPTION

MODEL	VOLTAGE (single-phase)		
	230 V	240 V	110 V
TOP MULTI 2	3.4 A	3.3 A	6.8 A
TOP MULTI 3	3.6 A	3.5 A	7.2 A

PALLETIZATION

MODEL	GROUPAGE			CONTAINER		
	n° pumps	H (mm)	kg	n° pumps	H (mm)	kg
TOP MULTI 2	60	1370	582	80	1780	770
TOP MULTI 3	60	1370	582	80	1780	770

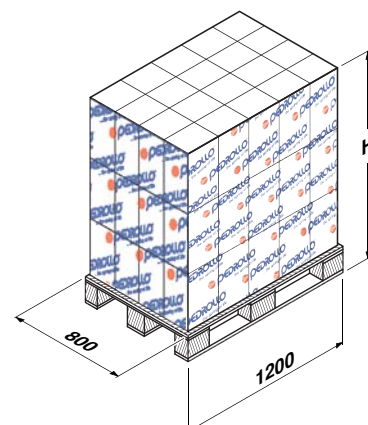



PERFORMANCE RANGE

- Flow rate up to **180 l/min** (10.8 m³/h)
- Head up to **103 m**

APPLICATION LIMITS

- Manometric suction lift up to **7 m**
- Liquid temperature between **-10 °C** and **+40 °C**
- Ambient temperature up to **+40 °C**
- Max. working pressure **10 bar**
- Continuous service **S1**

SAFETY STANDARDS

EN 60335-1
IEC 60335-1
CEI 61-150

EN 60034-1
IEC 60034-1
CEI 2-3



CERTIFICATIONS



INSTALLATION AND USE

Suitable for use with clean water and liquids that are not chemically aggressive towards the materials from which the pump is made. The high efficiency and adaptability of these pumps to even the most unusual of applications, makes them ideal for use in the domestic, civil and industrial sectors; in particular for the distribution of water in combination with pressure sets and for pressure boosting.

The pump should be installed in an enclosed environment, or at least sheltered from inclement weather.

OPTIONALS AVAILABLE ON REQUEST

- Suction and delivery ports with threaded flanges in compliance with ISO 228/1 (1" - 1¼" - 1½). MK 3-5 versions only
- Other voltages or 60 Hz frequency

GUARANTEE

1 year subject to terms and conditions

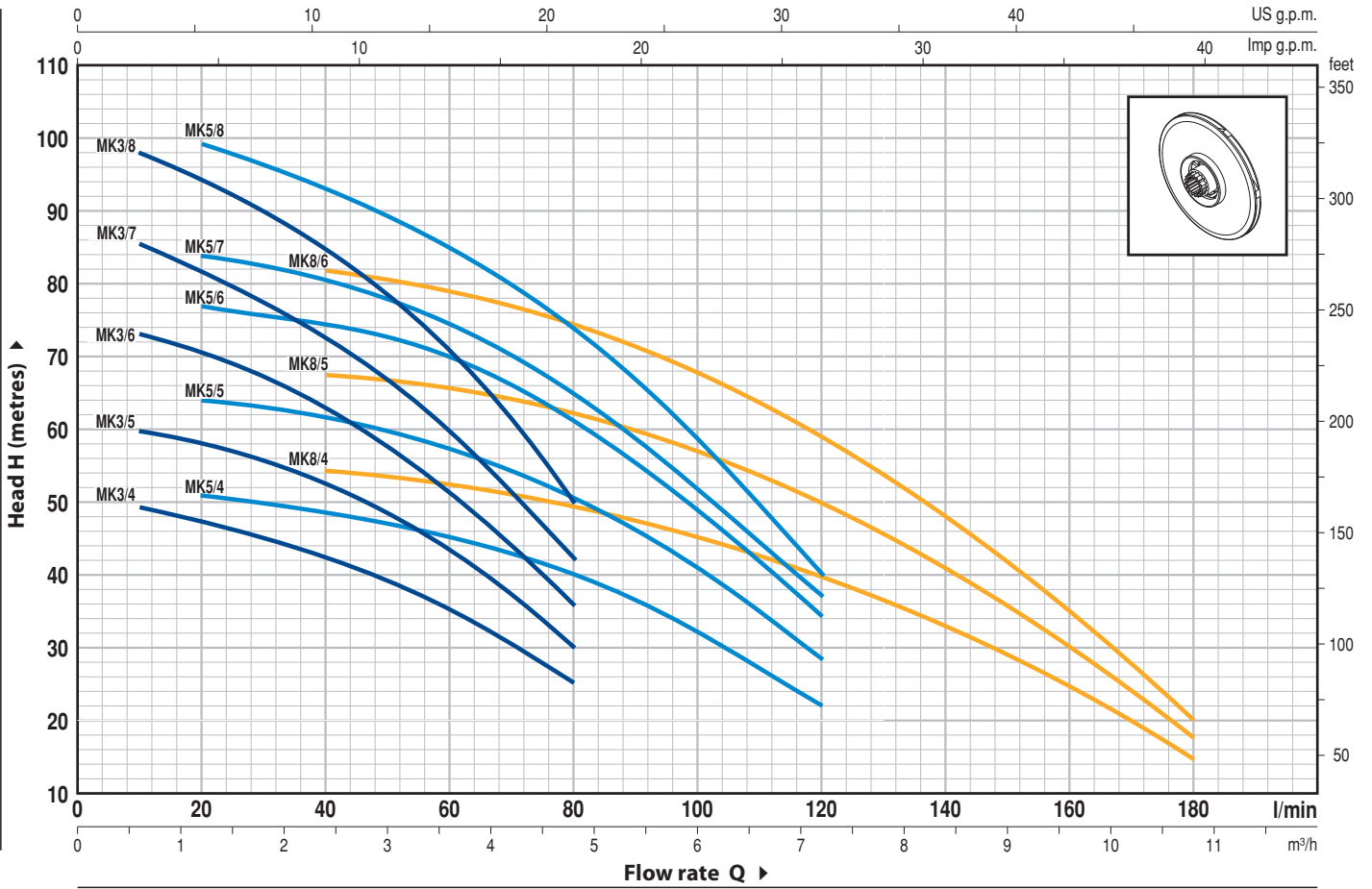
CHARACTERISTIC CURVES AND PERFORMANCE DATA
50 Hz n= 2900 1/min HS= 0 m

MODEL		POWER		Q	Flow rate														
Single-phase	Three-phase	kW	HP		m ³ /h	0	0.6	1.2	2.4	3.6	4.8	6.0	7.2	8.4	9.6	10.8			
				l/min	0	10	20	40	60	80	100	120	140	160	180				
MK3/4	MK 3/4	0.75	1	H metres	50	49	47	42.5	35	25									
MK3/5	MK 3/5	0.75	1		62	60	58.5	52.5	43.5	30									
MK3/6	MK 3/6	1.1	1.5		75	73	70	62.5	51.5	36									
MK3/7	MK 3/7	1.1	1.5		88	85	81.5	73	59.5	42									
MK3/8	MK 3/8	1.5	2		100	98	94	85	70.5	50									
MK5/4	MK 5/4	1.1	1.5		53	-	51	48	45	40	32	22							
MK5/5	MK 5/5	1.5	2		67	-	64	61	57.5	51	41.5	29							
MK5/6	MK 5/6	1.8	2.5		80	-	77	74	70	61	49	34							
MK5/7	MK 5/7	2.2	3		87	-	84	80	75	64.5	51.5	37							
MK5/8	MK 5/8	2.2	3		103	-	99	93	85	74.5	58.5	40							
MK8/4	MK 8/4	1.5	2		56.0	-	-	54.0	52.0	50.0	46.0	39.0	31.5	24.0	15.0				
MK8/5	MK 8/5	1.8	2.5		70.0	-	-	67.5	66.0	63.0	58.0	50.0	40.0	30.0	18.0				
MK8/6	MK 8/6	2.2	3	86.0	-	-	82.0	78.0	74.0	68.0	58.0	46.5	35.0	20.0					

Q = Flow rate H = Total manometric head HS = Suction height

Tolerance of characteristic curves in compliance with EN ISO 9906 App. A.

POS.	COMPONENT	CONSTRUCTION CHARACTERISTICS				
1	SUCTION BODY	Cast iron, complete with threaded suction port (flange for MK8 versions only) in compliance with ISO 228/1				
2	EXTERNAL SLEEVE	Stainless steel AISI 304				
3	DELIVERY BODY	Cast iron, complete with threaded suction port (flange for MK8 versions only) in compliance with ISO 228/1				
4	IMPELLERS AND DIFFUSERS	Noryl GFN2V				
5	DIAPHRAGMS	Stainless steel AISI 304 complete with anti-wear rings				
6	MOTOR SHAFT	Stainless steel EN 10088-3 - 1.4104				
7	MECHANICAL SEAL	<i>Seal</i>	<i>Shaft</i>	<i>Materials</i>		
		<i>Model</i>	<i>Diameter</i>	<i>Stationary ring</i>	<i>Rotational ring</i>	<i>Elastomer</i>
		FN-15	Ø 15 mm	Graphite	Ceramic	NBR

8 BEARINGS

Pump	Model
MK 3/4-5-6-7	6303 ZZ - C3 / 6203 ZZ
MK 3/8	
MK 5/4-5-6-7-8	6304 ZZ / 6204 ZZ
MK 8/4-5-6	

9 CAPACITOR

Pump	Capacitance	
	(230 V or 240 V)	(110 V)
Single-phase		
MKm 3/4	20 µF 450 VL	60 µF 300 VL
MKm 3/5	20 µF 450 VL	60 µF 300 VL
MKm 3/6	25 µF 450 VL	60 µF 300 VL
MKm 3/7	25 µF 450 VL	60 µF 300 VL
MKm 3/8	31.5 µF 450 VL	60 µF 250 VL
MKm 5/4	25 µF 450 VL	60 µF 250 VL
MKm 5/5	31.5 µF 450 VL	60 µF 250 VL
MKm 5/6	45 µF 450 VL	80 µF 250 VL
MKm 5/7	50 µF 450 VL	80 µF 250 VL
MKm 5/8	50 µF 450 VL	80 µF 250 VL
MKm 8/4	31.5 µF 450 VL	60 µF 250 VL
MKm 8/5	45 µF 450 VL	80 µF 250 VL
MKm 8/6	50 µF 450 VL	80 µF 250 VL

10 ELECTRIC MOTOR

⇒ Pumps fitted with the three-phase motor option offer IE2 (IEC 60034-30) class high performance

MKm: single-phase 230 V - 50 Hz
with thermal overload protector built-in to the winding.

MK: three-phase 230/400 V - 50 Hz.

– Insulation: F class.

– Protection: IP 44.

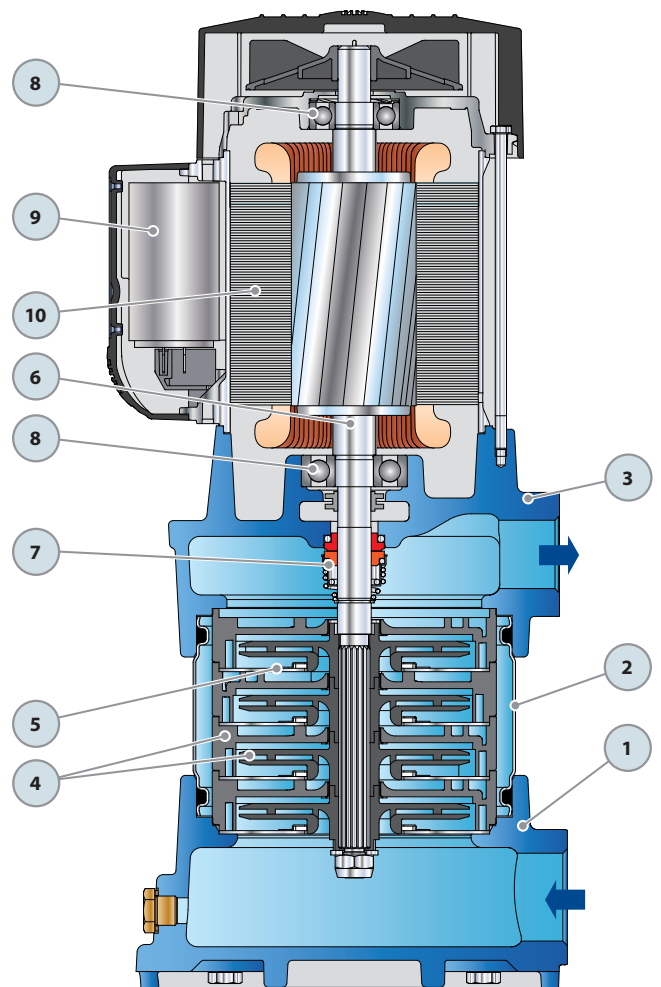

DIMENSIONS AND WEIGHT

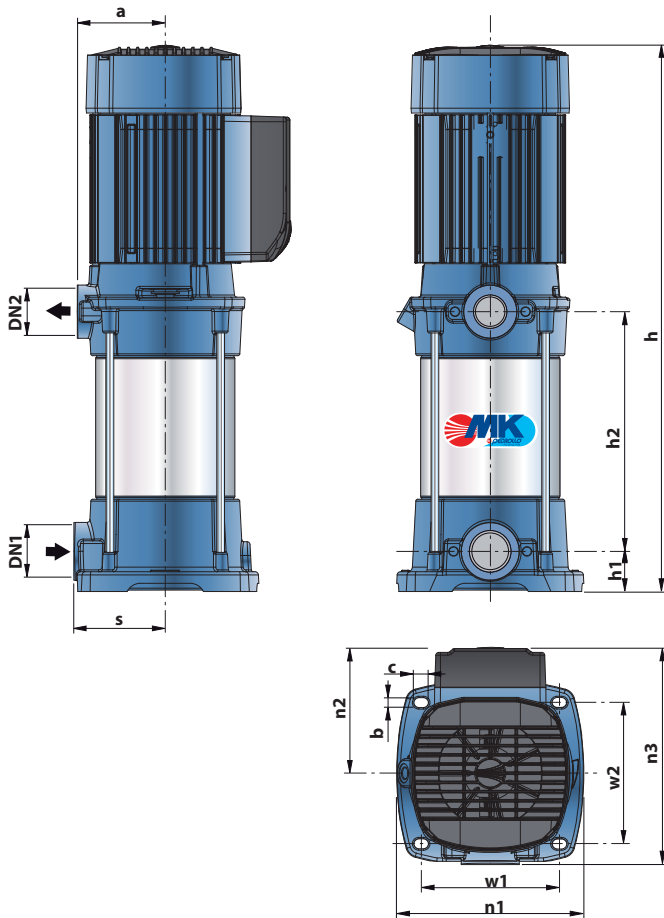

ABSORPTION

MODEL	VOLTAGE (single-phase)		
	230 V	240 V	110 V
Single-phase	230 V	240 V	110 V
MKm 3/4	5.0 A	4.8 A	10.0 A
MKm 3/5	6.0 A	5.8 A	12.0 A
MKm 3/6	6.5 A	6.3 A	13.0 A
MKm 3/7	7.0 A	6.8 A	14.0 A
MKm 3/8	9.0 A	8.7 A	18.0 A
MKm 5/4	6.5 A	6.3 A	13.0 A
MKm 5/5	8.5 A	8.2 A	17.0 A
MKm 5/6	9.5 A	9.1 A	19.0 A
MKm 5/7	10.5 A	10.2 A	21.0 A
MKm 5/8	11.5 A	11.0 A	23.0 A
MKm 8/4	8.5 A	8.2 A	17.0 A
MKm 8/5	9.5 A	9.1 A	19.0 A
MKm 8/6	11.5 A	11.0 A	23.0 A

MODEL	VOLTAGE (three-phase)					
	230 V	400 V	690 V	240 V	415 V	720 V
Three-phase	230 V	400 V	690 V	240 V	415 V	720 V
MKm 3/4	3.5 A	2.0 A	1.2 A	3.4 A	2.0 A	1.2 A
MKm 3/5	4.2 A	2.4 A	1.4 A	4.0 A	2.3 A	1.3 A
MKm 3/6	4.8 A	2.8 A	1.6 A	4.6 A	2.7 A	1.6 A
MKm 3/7	5.2 A	3.0 A	1.7 A	5.0 A	2.9 A	1.7 A
MKm 3/8	5.5 A	3.2 A	1.8 A	5.3 A	3.1 A	1.8 A
MKm 5/4	4.8 A	2.8 A	1.6 A	4.6 A	2.7 A	1.6 A
MKm 5/5	5.2 A	3.0 A	1.7 A	5.0 A	2.9 A	1.7 A
MKm 5/6	6.1 A	3.5 A	2.0 A	5.8 A	3.4 A	2.0 A
MKm 5/7	7.8 A	4.5 A	2.6 A	7.5 A	4.3 A	2.5 A
MKm 5/8	8.7 A	5.0 A	2.9 A	8.3 A	4.8 A	2.8 A
MKm 8/4	5.2 A	3.0 A	1.7 A	5.0 A	2.9 A	1.7 A
MKm 8/5	6.1 A	3.5 A	2.0 A	5.8 A	3.4 A	2.0 A
MKm 8/6	8.7 A	5.0 A	2.9 A	8.3 A	4.8 A	2.8 A

MODEL		PORTS		N° STAGES	DIMENSIONS mm										kg					
Single-phase	Three-phase	DN1	DN2		a	s	h	h1	h2	w1	w2	n1	n2	n3	b	c	1~	3~		
MKm 3/4	MKm 3/4	1 1/4"	1"	4	91	94.5	41.5	152	143	146	194	109.5	204	9.5	14.5			20.0	19.6	
MKm 3/5	MKm 3/5			5														176	20.8	20.3
MKm 3/6	MKm 3/6			6														220	21.1	21.6
MKm 3/7	MKm 3/7			7														224	21.8	22.3
MKm 3/8	MKm 3/8			8														248	26.6	25.6
MKm 5/4	MKm 5/4			4														152	22.3	21.6
MKm 5/5	MKm 5/5			5														176	24.3	23.4
MKm 5/6	MKm 5/6			6														200	25.8	25.0
MKm 5/7	MKm 5/7	7	224	27.3	26.6															
MKm 5/8	MKm 5/8	8	248	28.0	27.3															
MKm 8/4	MKm 8/4	2"	1 1/2"	4	114	162	41.5	152	143	146	194	109.5	204	9.5	14.5			23.6	22.7	
MKm 8/5	MKm 8/5			5														176	25.1	24.3
MKm 8/6	MKm 8/6			6														200	26.6	25.9

PALLETIZATION

MODEL		GROUPAGE / CONTAINER			
Single-phase	Three-phase	n° pumps	H (mm)	1~	3~
MKm 3/4	MKm 3/4	30	1400	620	610
MKm 3/5	MKm 3/5	30	1400	640	630
MKm 3/6	MKm 3/6	30	1400	650	670
MKm 3/7	MKm 3/7	30	1400	670	690
MKm 3/8	MKm 3/8	30	1500	820	790
MKm 5/4	MKm 5/4	30	1500	690	670
MKm 5/5	MKm 5/5	30	1500	750	720
MKm 5/6	MKm 5/6	30	1500	790	770
MKm 5/7	MKm 5/7	30	1500	840	820
MKm 5/8	MKm 5/8	30	1500	860	840
MKm 8/4	MKm 8/4	30	1500	729	699
MKm 8/5	MKm 8/5	30	1500	769	749
MKm 8/6	MKm 8/6	30	1500	818	798

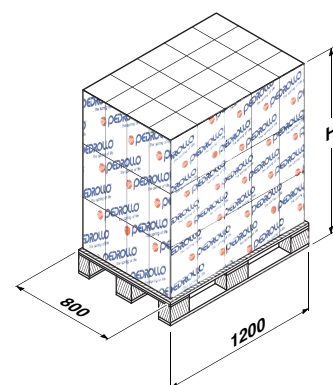



PERFORMANCE RANGE

- Flow rate up to **120 l/min** (7.2 m³/h)
- Head up to **105 m**

APPLICATION LIMITS

- Maximum liquid temperature **+40 °C**
- Maximum sand content **50 g/m³**
- **20 m** maximum immersion depth
- Continuous service **S1**

CONSTRUCTION AND SAFETY STANDARDS

➔ Complete with **20 m** long power cable

EN 60335-1
IEC 60335-1
CEI 61-150

EN 60034-1
IEC 60034-1
CEI 2-3



CERTIFICATIONS



INSTALLATION AND USE

As a result of their high efficiency and reliability they are suitable for use with clean water in domestic, civil and agricultural applications such as the distribution of water in combination with pressure sets, for the irrigation of gardens and allotments and for pressure boosting, etc.

OPTIONALS AVAILABLE ON REQUEST

- Pumps fitted with power cables of other lengths
- Other voltages or 60 Hz frequency

GUARANTEE

1 year subject to terms and conditions

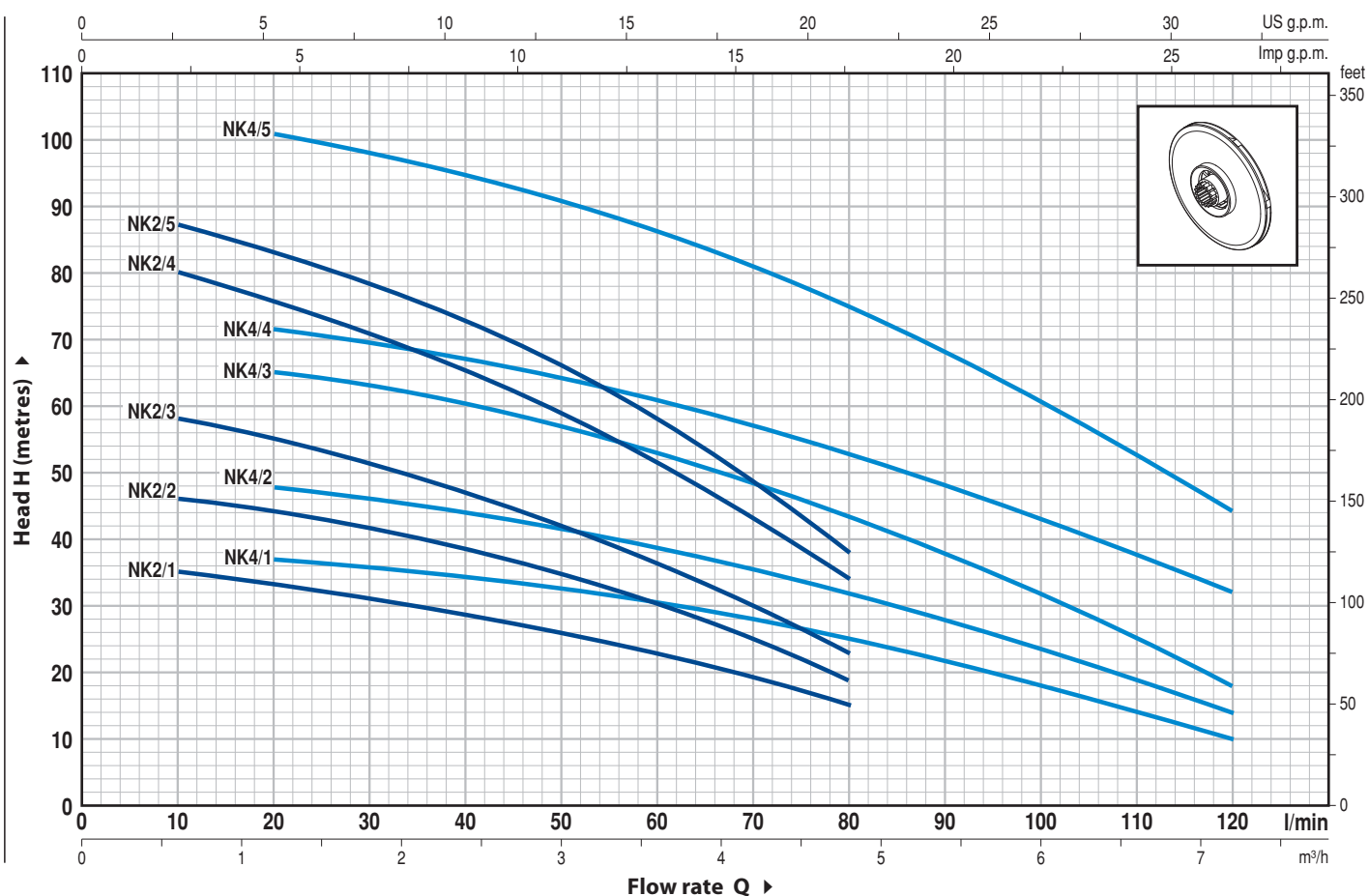
CHARACTERISTIC CURVES AND PERFORMANCE DATA
50 Hz n = 2900 1/min

VERSION WITHOUT FLOAT SWITCH

MODEL		POWER		Q	Flow rate												
Single-phase	Three-phase	kW	HP		m ³ /h	0	0.6	1.2	1.8	2.4	3.0	3.6	4.2	4.8	5.4	6.0	6.6
				l/min	0	10	20	30	40	50	60	70	80	90	100	110	120
NKm 2/1	-	0.45	0.6	H metres	36	35	33	31	28.5	26	23	19	15				
NKm 2/2	-	0.55	0.75		48	46	44	41.5	39	35	30	25	19				
NKm 2/3	NK 2/3	0.75	1		60	58	55	51	47	42	36	30	23				
NKm 2/4	NK 2/4	1.1	1.5		84	80	75	70	65	59	51	42.5	34				
NKm 2/5	NK 2/5	1.5	2		90	87	83	78	73	66	58	48	38				
NKm 4/1	-	0.55	0.75		40	-	37	36	34.5	32.5	30	28	25	21.5	18.5	14.5	10
NKm 4/2	NK 4/2	0.75	1		50	-	48	46	44	41	38	35	32	28	24	19	14
NKm 4/3	NK 4/3	1.1	1.5		67	-	65	62.5	60	56.5	52	48	44	38	32	25	18
NKm 4/4	NK 4/4	1.5	2		75	-	72	69	66	64	60	57	53	48	43	38	32
NKm 4/5	NK 4/5	2.2	3		105	-	101	98	94	90	86	80	75	67	60	52	44

"GE" VERSION WITH FLOAT SWITCH

MODEL		POWER		Q	Flow rate												
Single-phase		kW	HP		m ³ /h	0	0.6	1.2	1.8	2.4	3.0	3.6	4.2	4.8	5.4	6.0	6.6
				l/min	0	10	20	30	40	50	60	70	80	90	100	110	120
NKm 2/1 - GE		0.45	0.6	H metres	36	35	33	31	28.5	26	23	19	15				
NKm 2/2 - GE		0.55	0.75		48	46	44	41.5	39	35	30	25	19				
NKm 2/3 - GE		0.75	1		60	58	55	51	47	42	36	30	23				
NKm 2/4 - GE		1.1	1.5		84	80	75	70	65	59	51	42.5	34				
NKm 2/5 - GE		1.5	2		90	87	83	78	73	66	58	48	38				
NKm 4/1 - GE		0.55	0.75		40	-	37	36	34.5	32.5	30	28	25	21.5	18.5	14.5	10
NKm 4/2 - GE		0.75	1		50	-	48	46	44	41	38	35	32	28	24	19	14
NKm 4/3 - GE		1.1	1.5		67	-	65	62.5	60	56.5	52	48	44	38	32	25	18
NKm 4/4 - GE		1.5	2		75	-	72	69	66	64	60	57	53	48	43	38	32
NKm 4/5 - GE		2.2	3		105	-	101	98	94	90	86	80	75	67	60	52	44

Q = Flow rate H = Total manometric head

Tolerance of characteristic curves in compliance with EN ISO 9906 App. A.

POS.	COMPONENT	CONSTRUCTION CHARACTERISTICS				
1	EXTERNAL SLEEVE	Stainless steel AISI 304, complete with threaded delivery port in compliance with ISO 228/1				
2	SUCTION FILTER	Stainless steel AISI 304				
3	MOTOR SLEEVE	Stainless steel AISI 304				
4	IMPELLERS AND DIFFUSERS	Noryl GFN2V				
5	DIAPHRAGMS	Stainless steel AISI 304, complete with anti-wear ring				
6	MOTOR SHAFT	Stainless steel EN 10088-3 - 1.4104				
7	TWO MECHANICAL SEALS SEPARATED BY AN OIL CHAMBER					
	<i>Seal</i>	<i>Shaft</i>	<i>Position</i>	<i>Stationary ring</i>	<i>Rotational ring</i>	<i>Materials</i>
	<i>Model</i>	<i>Diameter</i>				<i>Elastomer</i>
	MG1-16	Ø 16 mm	Motor side	Silicon carbide	Graphite	NBR
	MG1-15 SIC	Ø 15 mm	Pump side	Silicon carbide	Silicon carbide	NBR
8	BEARINGS	6303 2RS - C3 / 6203 ZZ - C3				
9	CAPACITOR					
	<i>Pump</i>	<i>Capacitance</i>				
	<i>Single-phase</i>	<i>(230 V or 240 V)</i>	<i>(110 V)</i>			
	NKm 2/1	16 µF 500 VL	30 µF 250 VL			
	NKm 2/2	16 µF 500 VL	30 µF 250 VL			
	NKm 4/1					
	NKm 2/3	20 µF 500 VL	-			
	NKm 4/2					
	NKm 2/4	25 µF 500 VL	-			
	NKm 4/3					
10	ELECTRIC MOTOR					
	NKm: single-phase 230 V - 50 Hz with thermal overload protector built-in to the winding.					
	NK: three-phase 400 V - 50 Hz.					
	- Insulation: F class.					
	- Protection: IP 68.					
11	POWER CABLE					
	⇒ 20 metre long DRINCABLE® for permanent immersion in drinking water					
12	FLOAT SWITCH					

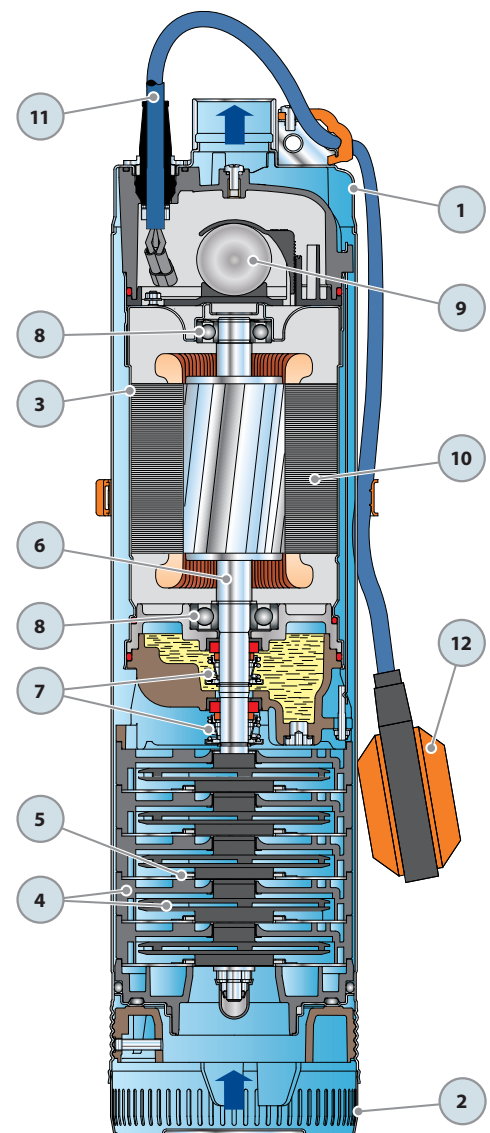

DIMENSIONS AND WEIGHT

MODEL		PORT DN	N° STAGES	DIMENSIONS mm		kg	
Single-phase	Three-phase			Ø	h	1~	3~
NKm 2/1	-	1 1/4"	3	135	495	13.9	-
NKm 2/2	-		4		519	14.5	-
NKm 2/3	-		5		573	16.3	-
-	NK 2/3		5		543	-	15.0
NKm 2/4	NK 2/4		7		621	18.1	18.0
NKm 4/1	-		4		519	14.3	-
NKm 4/2	-		5		573	16.2	-
-	NK 4/2		5		543	-	15.1
NKm 4/3	NK 4/3		7		621	18.1	18.0

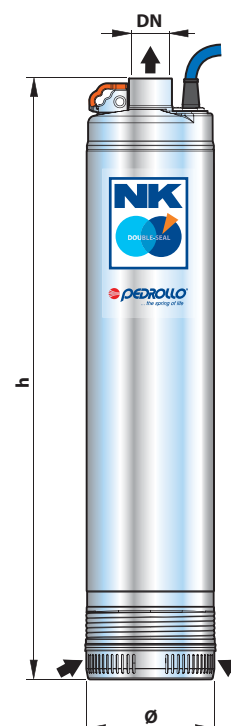

ABSORPTION

MODEL	VOLTAGE (single-phase)		
	230 V	240 V	110 V
NKm 2/1	4.5 A	4.5 A	9.0 A
NKm 2/2	5.0 A	5.0 A	10.0 A
NKm 2/3	6.0 A	6.0 A	-
NKm 2/4	7.5 A	7.5 A	-
NKm 4/1	5.0 A	5.0 A	10.0 A
NKm 4/2	6.0 A	6.0 A	-
NKm 4/3	7.5 A	7.5 A	-

MODEL	VOLTAGE (three-phase)			
	230 V	400 V	240 V	415 V
NK 2/3	4.5 A	2.6 A	4.5 A	2.6 A
NK 2/4	5.2 A	3.0 A	5.2 A	3.0 A
NK 4/2	4.5 A	2.6 A	4.5 A	2.6 A
NK 4/3	5.2 A	3.0 A	5.2 A	3.0 A

PALLETIZATION

MODEL		GROUPAGE				CONTAINER			
Single-phase	Three-phase	n° pumps	H (mm)	kg		n° pumps	H (mm)	kg	
				1~	3~			1~	3~
NKm 2/1	-	30	1015	434	-	60	1890	852	-
NKm 2/2	-	30	1015	452	-	60	1890	887	-
NKm 4/1	-	30	1015	452	-	60	1890	887	-
NKm 2/3	-	25	869	425	-	40	1307	670	-
NKm 4/2	-	25	869	425	-	40	1307	670	-
-	NK 2/3 NK 4/2	30	1015	-	470	60	1890	-	915
NKm 2/4	NK 2/4	25	869	469	467	40	1307	740	737
NKm 4/3	NK 4/3	25	869	469	467	40	1307	740	737

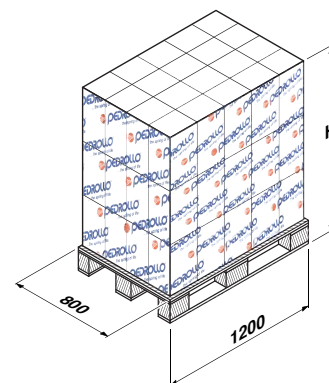

NK (1.5÷2.2 kW)

POS.	COMPONENT	CONSTRUCTION CHARACTERISTICS				
1	EXTERNAL SLEEVE	Stainless steel AISI 304, complete with threaded delivery port in compliance with ISO 228/1				
2	SUCTION FILTER	Stainless steel AISI 304				
3	MOTOR SLEEVE	Stainless steel AISI 304				
4	IMPELLERS AND DIFFUSERS	Noryl GFN2V				
5	DIAPHRAGMS	Stainless steel AISI 304, complete with anti-wear ring				
6	MOTOR SHAFT	Stainless steel EN 10088-3 - 1.4104				
7	TWO MECHANICAL SEALS SEPARATED BY AN OIL CHAMBER					
	<i>Seal</i>	<i>Shaft</i>	<i>Position</i>	<i>Materials</i>		
	<i>Model</i>	<i>Diameter</i>		<i>Stationary ring</i>	<i>Rotational ring</i>	<i>Elastomer</i>
	MG1-19	Ø 19 mm	Motor side	Silicon carbide	Graphite	NBR
	MG1-18 SIC	Ø 18 mm	Pump side	Silicon carbide	Silicon carbide	NBR
8	BEARINGS	6304 2RS - C3 / 6203 ZZ - C3				
9	CAPACITOR					
	<i>Pump</i>	<i>Capacitance</i>				
	<i>Single-phase</i>	<i>(230 V or 240 V)</i>				
	NKm 2/5	35 µF 450 VL				
	NKm 4/4	50 µF 450 VL				
	NKm 4/5	50 µF 450 VL				
10	ELECTRIC MOTOR					
	NKm: single-phase 230 V - 50 Hz.					
	Windings up to 1.5 kW with built-in thermal overload protector.					
	⇒ The NKm4/5 2.2 kW pump is equipped with an external manual reset overload protector housed in the control box.					
	NK: three-phase 400 V - 50 Hz.					
	– Insulation: F class.					
	– Protection: IP 68.					
11	POWER CABLE					
	⇒ 20 metre long DRINCABLE® with removable connector for permanent immersion in drinking water					
12	CONTROL BOX (for single-phase versions)					
13	FLOAT SWITCH					

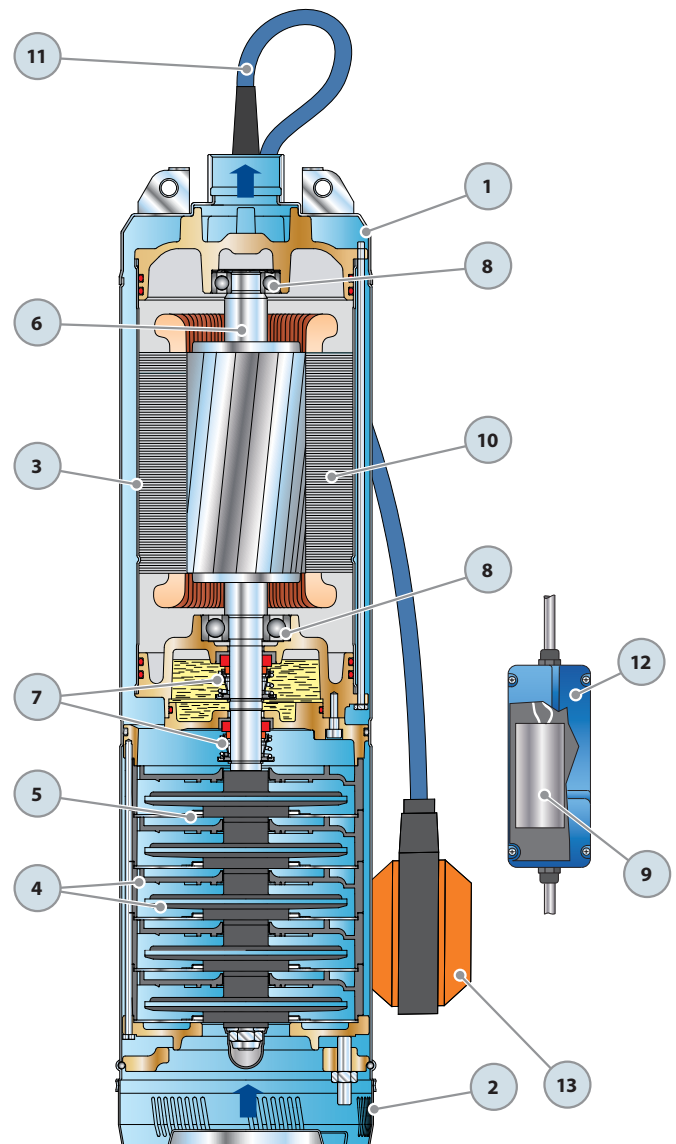

DIMENSIONS AND WEIGHT

MODEL		PORT DN	N° STAGES	DIMENSIONS mm		kg	
Single-phase	Three-phase			Ø	h	1~	3~
NKm 2/5	NK 2/5	1 1/4"	6	153	612	26.7	23.8
NKm 4/4	NK 4/4		5		582	26.0	24.4
NKm 4/5	NK 4/5		7		642	30.5	28.0



ABSORPTION

MODEL	VOLTAGE (single-phase)	
	230 V	240 V
Single-phase		
NKm 2/5	9.0 A	9.0 A
NKm 4/4	9.5 A	9.5 A
NKm 4/5	14.0 A	14.0 A

MODEL	VOLTAGE (three-phase)			
	230 V	400 V	240 V	415 V
Three-phase				
NK 2/5	6.2 A	3.6 A	6.2 A	3.6 A
NK 4/4	6.2 A	3.6 A	6.2 A	3.6 A
NK 4/5	8.5 A	4.9 A	8.5 A	4.9 A

PALLETIZATION

MODEL		GROUPAGE				CONTAINER			
Single-phase	Three-phase	n° pumps	H (mm)	kg		n° pumps	H (mm)	kg	
				1~	3~			1~	3~
NKm 2/5	NK 2/5	20	1100	551	493	40	2060	1085	969
NKm 4/4	NK 4/4	20	1100	537	505	40	2060	1058	993
NKm 4/5	NK 4/5	20	1100	627	576	40	2060	1237	1136

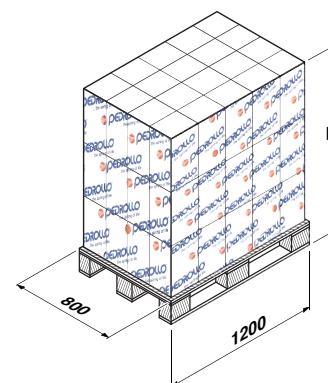



PERFORMANCE RANGE

- Flow rate up to **120 l/min** (7.2 m³/h)
- Head up to **105 m**

APPLICATION LIMITS

- Manometric suction lift up to **7 m**
- Maximum liquid temperature **+40 °C**
- Max. working pressure **10 bar**
- Continuous service **S1**

CONSTRUCTION AND SAFETY STANDARDS

Complete with **2 m** long power cable

EN 60335-1
IEC 60335-1
CEI 61-150

EN 60034-1
IEC 60034-1
CEI 2-3



INSTALLATION AND USE

Suitable for use with clean water and liquids that are not chemically aggressive towards the materials from which the pump is made. As a result of their reliability and quietness they are suitable for use in domestic and civil applications where there is a lack of ventilation or space as well as in wet environments, etc.

They are capable of functioning at depths of up to 20 m provided that they are equipped with a sufficiently long power cable.

OPTIONALS AVAILABLE ON REQUEST

- Other voltages or 60 Hz frequency

GUARANTEE

1 year subject to terms and conditions

CERTIFICATIONS



CHARACTERISTIC CURVES AND PERFORMANCE DATA

50 Hz n= 2900 1/min HS= 0 m

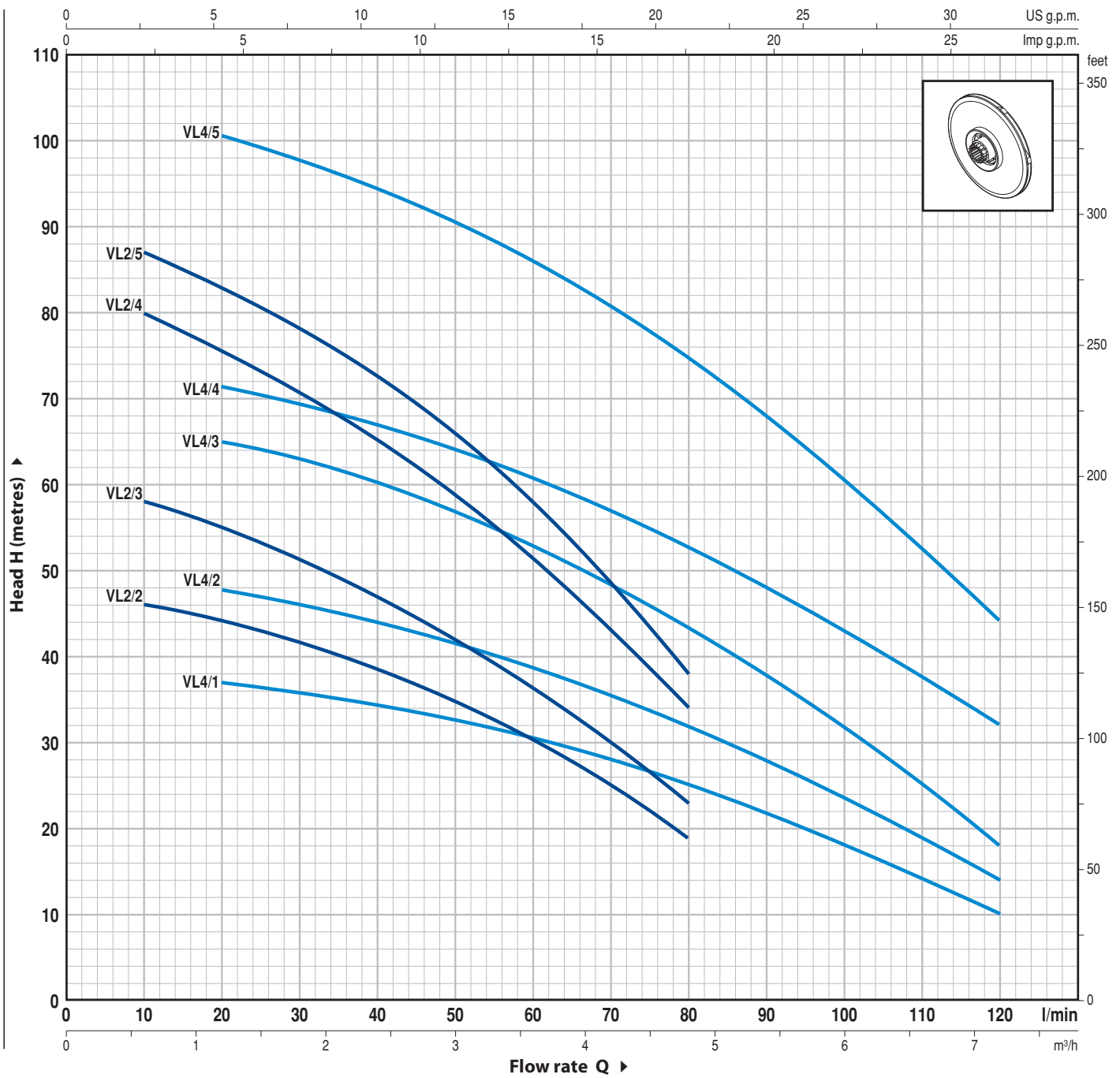

MODEL		POWER		Q	Flow rate												
Single-phase	Three-phase	kW	HP		m³/h	0	0.6	1.2	1.8	2.4	3.0	3.6	4.2	4.8	5.4	6.0	6.6
				l/min	0	10	20	30	40	50	60	70	80	90	100	110	120
VLm 2/2	-	0.55	0.75	H metres	48	46	44	41.5	39	35	30	25	19				
VLm 2/3	VL 2/3	0.75	1		60	58	55	51	47	42	36	30	23				
VLm 2/4	VL 2/4	1.1	1.5		84	80	75	70	65	59	51	42.5	34				
VLm 2/5	VL 2/5	1.5	2		90	87	83	78	73	66	58	48	38				
VLm 4/1	-	0.55	0.75		40	-	37	36	34.5	32.5	30	28	25	21.5	18.5	14.5	10
VLm 4/2	VL 4/2	0.75	1		50	-	48	46	44	41	38	35	32	28	24	19	14
VLm 4/3	VL 4/3	1.1	1.5		67	-	65	62.5	60	56.5	52	48	44	38	32	25	18
VLm 4/4	VL 4/4	1.5	2		75	-	72	69	66	64	60	57	53	48	43	38	32
VLm 4/5	VL 4/5	2.2	3		105	-	101	98	94	90	86	80	75	67	60	52	44

Q = Flow rate H = Total manometric head

Tolerance of characteristic curves in compliance with EN ISO 9906 App. A.

POS.	COMPONENT	CONSTRUCTION CHARACTERISTICS				
1	SUCTION BODY	Stainless steel AISI 304, complete with threaded suction port in compliance with ISO 228/1				
2	EXTERNAL SLEEVE	Stainless steel AISI 304, complete with threaded delivery port in compliance with ISO 228/1				
3	MOTOR SLEEVE	Stainless steel AISI 304				
4	IMPELLERS AND DIFFUSERS	Noryl GFN2V				
5	DIAPHRAGMS	Stainless steel AISI 304, complete with anti-wear ring				
6	MOTOR SHAFT	Stainless steel EN 10088-3 - 1.4104				
7	TWO MECHANICAL SEALS SEPARATED BY AN OIL CHAMBER					
	<i>Seal</i>	<i>Shaft</i>	<i>Position</i>	<i>Materials</i>		
	<i>Model</i>	<i>Diameter</i>		<i>Stationary ring</i>	<i>Rotational ring</i>	<i>Elastomer</i>
	MG1-16	Ø 16 mm	Motor side	Silicon carbide	Graphite	NBR
	MG1-15 SIC	Ø 15 mm	Pump side	Silicon carbide	Silicon carbide	NBR
8	BEARINGS	6303 2RS - C3 / 6203 ZZ - C3				
9	CAPACITOR					
	<i>Pump</i>	<i>Capacitance</i>				
	<i>Single-phase</i>	<i>(230 V or 240 V)</i>	<i>(110 V)</i>			
	VLm 2/2	16 µF 500 VL	30 µF 250 VL			
	VLm 4/1					
	VLm 2/3	20 µF 500 VL	-			
	VLm 4/2					
	VLm 2/4	25 µF 500 VL	-			
	VLm 4/3					
10	ELECTRIC MOTOR					
	VLm: single-phase 230 V - 50 Hz with built-in overload protector.					
	VL: three-phase 400 V - 50 Hz.					
	- Insulation: F class.					
	- Protection: IP 68.					
11	POWER CABLE					
	2 metre long "H07 RN-F" cable					

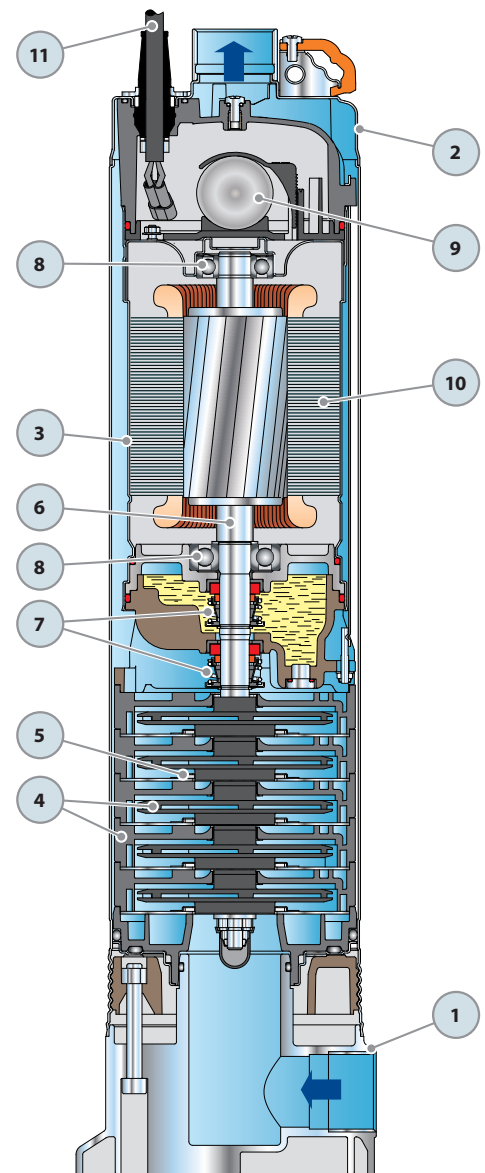

DIMENSIONS AND WEIGHT

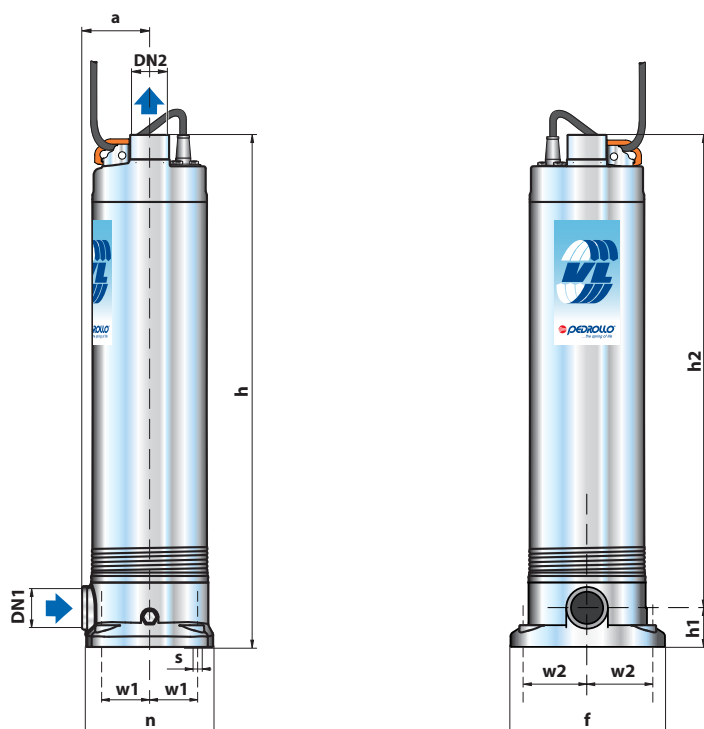

MODEL		PORTS		N° STAGES	DIMENSIONS mm									kg			
Single-phase	Three-phase	DN1	DN2		a	f	h	h1	h2	n	w1	w2	s	1~	3~		
VLm 2/2 VLm 4/1	-	1 1/4"	1 1/4"	4	74	166	565	45	520	146	52.5	62.5	11	15.0	-		
VLm 2/3 VLm 4/2	-			5			618		573							18.0	-
-	VL 2/3 VL 4/2			5			588		543								
VLm 2/4 VLm 4/3	VL 2/4 VL 4/3			7			665		620							20.1	18.9

ABSORPTION

MODEL	VOLTAGE (single-phase)		
	230 V	240 V	110 V
Single-phase	230 V	240 V	110 V
VLm 2/2	5.0 A	5.0 A	10.0 A
VLm 2/3	6.0 A	6.0 A	-
VLm 2/4	7.5 A	7.5 A	-
VLm 4/1	5.0 A	5.0 A	10.0 A
VLm 4/2	6.0 A	6.0 A	-
VLm 4/3	7.5 A	7.5 A	-

MODEL	VOLTAGE (three-phase)			
	230 V	400 V	240 V	415 V
Three-phase	230 V	400 V	240 V	415 V
VL 2/3	4.5 A	2.6 A	4.5 A	2.6 A
VL 2/4	5.2 A	3.0 A	5.2 A	3.0 A
VL 4/2	4.5 A	2.6 A	4.5 A	2.6 A
VL 4/3	5.2 A	3.0 A	5.2 A	3.0 A

PALLETIZATION

MODEL		GROUPAGE				CONTAINER			
		n° pumps	H (mm)	kg		n° pumps	H (mm)	kg	
Single-phase	Three-phase			1~	3~			1~	3~
VLm 2/2 VLm 4/1	-	25	869	361	-	40	1307	615	-
VLm 2/3 VLm 4/2	-	25	869	468	-	40	1307	738	-
-	VL 2/3 VL 4/2	25	869	-	432	40	1307	-	681
VLm 2/4 VLm 4/3	VL 2/4 VL 4/3	25	869	518	488	40	1307	819	771

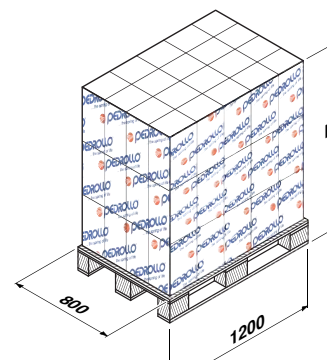

POS.	COMPONENT	CONSTRUCTION CHARACTERISTICS				
1	SUCTION BODY	Stainless steel AISI 304, complete with threaded suction port in compliance with ISO 228/1				
2	EXTERNAL SLEEVE	Stainless steel AISI 304, complete with threaded delivery port in compliance with ISO 228/1				
3	MOTOR SLEEVE	Stainless steel AISI 304				
4	IMPELLERS AND DIFFUSERS	Noryl GFN2V				
5	DIAPHRAGMS	Stainless steel AISI 304, complete with anti-wear ring				
6	MOTOR SHAFT	Stainless steel EN 10088-3 - 1.4104				
7	TWO MECHANICAL SEALS SEPARATED BY AN OIL CHAMBER					
	Seal	Shaft	Position	Materials		
	<i>Model</i>	<i>Diameter</i>		<i>Stationary ring</i>	<i>Rotational ring</i>	<i>Elastomer</i>
	MG1-19	Ø 19 mm	Motor side	Silicon carbide	Graphite	NBR
	MG1-18 SIC	Ø 18 mm	Pump side	Silicon carbide	Silicon carbide	NBR
8	BEARINGS	6304 2RS - C3 / 6203 ZZ - C3				
9	CAPACITOR					
	Pump	Capacitance				
	<i>Single-phase</i>	<i>(230 V or 240 V)</i>				
	VLm 2/5	35 µF 450 VL				
	VLm 4/4	50 µF 450 VL				
	VLm 4/5	50 µF 450 VL				
10	ELECTRIC MOTOR					
	VLm: single-phase 230 V - 50 Hz.		Windings up to 1.5 kW with built-in thermal overload protector.			
	➡ The VLm4/5 2.2 kW pump is equipped with an external manual reset overload protector housed in the control box.					
	VL: three-phase 400 V - 50 Hz.		– Insulation: F class.			
			– Protection: IP 68.			
11	POWER CABLE					
	2 metre long "H07 RN-F" cable with removable connector					
12	CONTROL BOX (for single-phase versions only)					
	Complete with capacitor and power cable with Schuko plug					

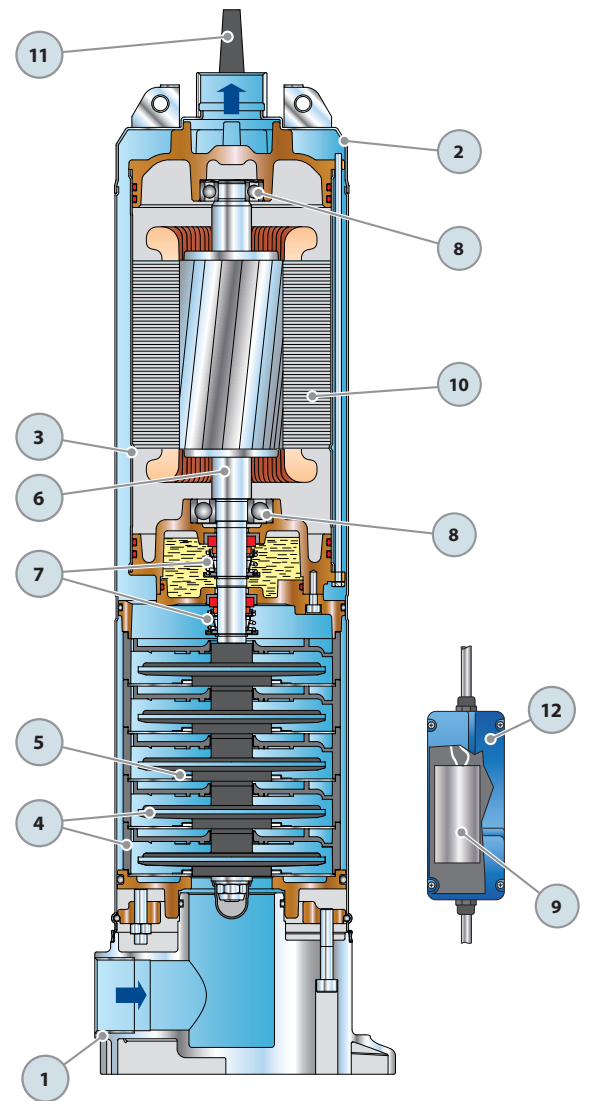

DIMENSIONS AND WEIGHT

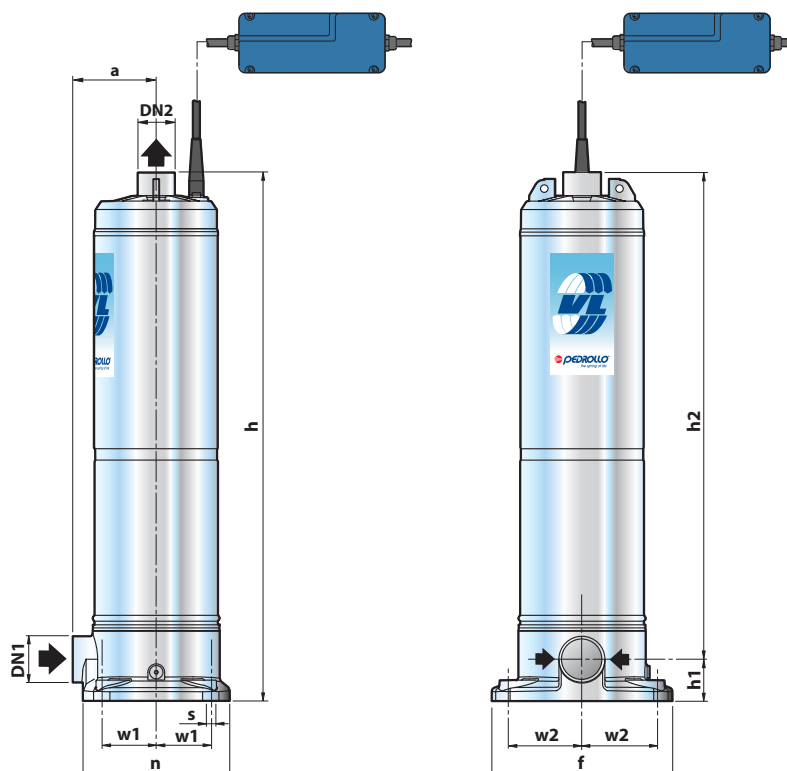

MODEL		PORTS		N° STAGES	DIMENSIONS mm									kg	
Single-phase	Three-phase	DN1	DN2		a	f	h	h1	h2	n	w1	w2	s	1~	3~
VLm 2/5	VL 2/5	1½"	1¼"	6	100	223	663	50	613	183	62	88.5	11	31.7	28.8
VLm 4/4	VL 4/4			5	633		583		31.0					29.4	
VLm 4/5	VL 4/5			7	693		643		35.5					33.0	

ABSORPTION

MODEL	VOLTAGE (single-phase)	
Single-phase	230 V	240 V
VLm 2/5	9.0 A	9.0 A
VLm 4/4	9.5 A	9.5 A
VLm 4/5	14.0 A	14.0 A

MODEL	VOLTAGE (three-phase)			
Three-phase	230 V	400 V	240 V	415 V
VL 2/5	6.2 A	3.6 A	6.2 A	3.6 A
VL 4/4	6.2 A	3.6 A	6.2 A	3.6 A
VL 4/5	8.5 A	4.9 A	8.5 A	4.9 A

PALLETIZATION

MODEL		GROUPAGE				CONTAINER			
Single-phase	Three-phase	n° pumps	H (mm)	kg		n° pumps	H (mm)	kg	
				1~	3~			1~	3~
VLm 2/5	VL 2/5	25	1340	809	737	40	2060	1285	1169
VLm 4/4	VL 4/4	25	1340	792	752	40	2060	1258	1193
VLm 4/5	VL 4/5	25	1340	905	841	40	2060	1437	1336

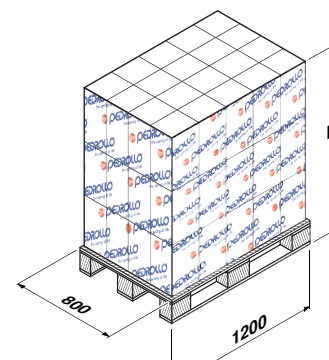



PERFORMANCE RANGE

- Flow rate up to **120 l/min** (7.2 m³/h)
- Head up to **105 m**

APPLICATION LIMITS

- Manometric suction lift up to **7 m**
- Maximum liquid temperature **+40 °C**
- Max. working pressure **10 bar**
- Continuous service **S1**

CONSTRUCTION AND SAFETY STANDARDS

Complete with **2 m** long power cable

EN 60335-1
IEC 60335-1
CEI 61-150

EN 60034-1
IEC 60034-1
CEI 2-3



CERTIFICATIONS



INSTALLATION AND USE

Suitable for use with clean water and liquids that are not chemically aggressive towards the materials from which the pump is made. As a result of their reliability, quietness, high efficiency and leak proof design in the event of seal failure, they are suitable for use in domestic and civil applications where there is a lack of ventilation or space as well as in closed spaces, wet areas and on delicate surfaces (e.g. wooden floorboards, carpets, etc). They are capable of functioning at depths of up to 20 m provided that they are equipped with a sufficiently long power cable.

OPTIONALS AVAILABLE ON REQUEST

- Other voltages or 60 Hz frequency

GUARANTEE

1 year subject to terms and conditions

CHARACTERISTIC CURVES AND PERFORMANCE DATA

50 Hz n= 2900 1/min HS= 0 m

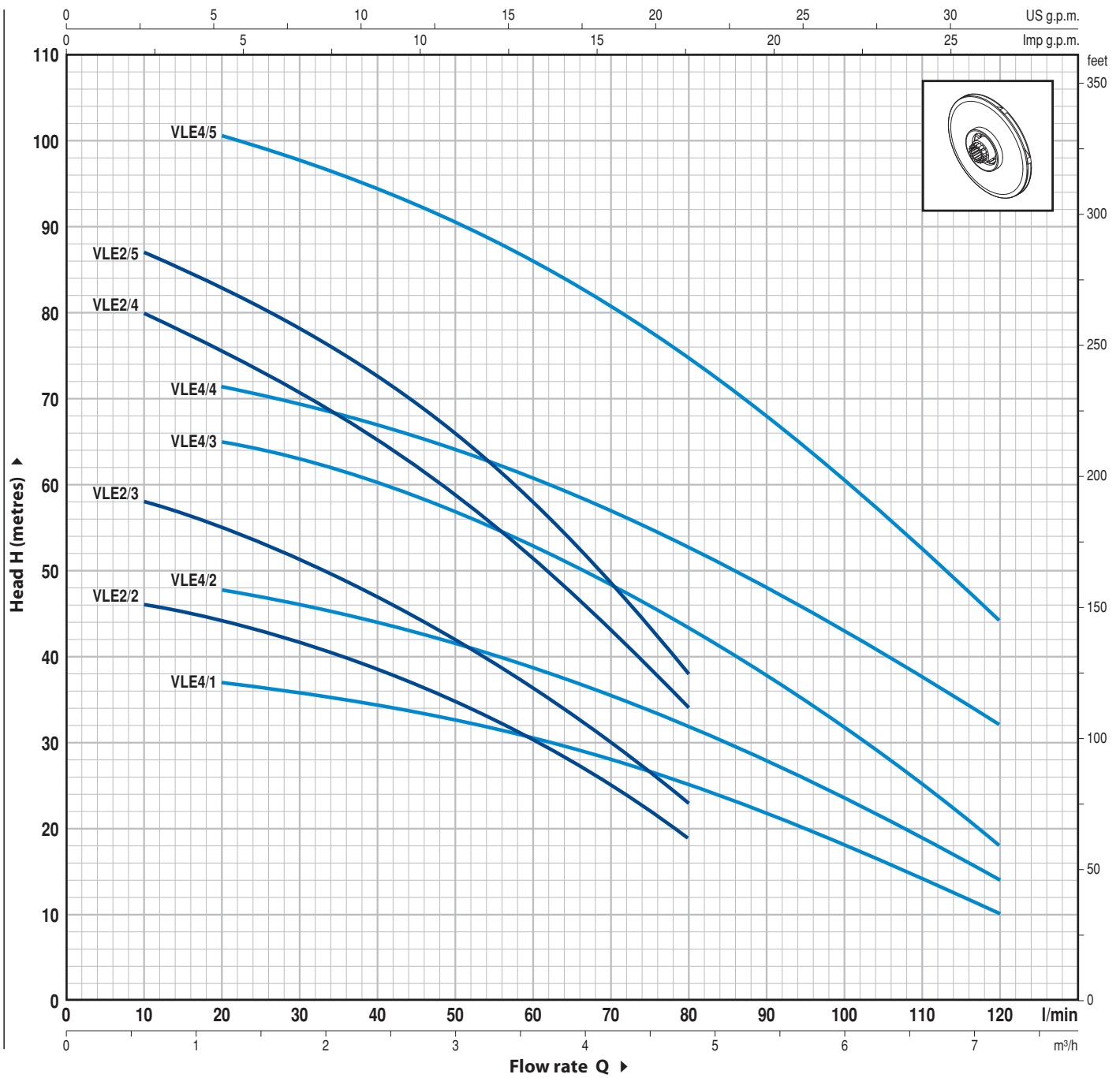

MODEL		POWER		Q	Flow rate													
Single-phase	Three-phase	kW	HP		m³/h	0	0.6	1.2	1.8	2.4	3.0	3.6	4.2	4.8	5.4	6.0	6.6	7.2
				l/min	0	10	20	30	40	50	60	70	80	90	100	110	120	
VLEm 2/2	-	0.55	0.75	H metres	48	46	44	41.5	39	35	30	25	19					
VLEm 2/3	VLE 2/3	0.75	1		60	58	55	51	47	42	36	30	23					
VLEm 2/4	VLE 2/4	1.1	1.5		84	80	75	70	65	59	51	42.5	34					
VLEm 2/5	VLE 2/5	1.5	2		90	87	83	78	73	66	58	48	38					
VLEm 4/1	-	0.55	0.75		40	-	37	36	34.5	32.5	30	28	25	21.5	18.5	14.5	10	
VLEm 4/2	VLE 4/2	0.75	1		50	-	48	46	44	41	38	35	32	28	24	19	14	
VLEm 4/3	VLE 4/3	1.1	1.5		67	-	65	62.5	60	56.5	52	48	44	38	32	25	18	
VLEm 4/4	VLE 4/4	1.5	2		75	-	72	69	66	64	60	57	53	48	43	38	32	
VLEm 4/5	VLE 4/5	2.2	3		105	-	101	98	94	90	86	80	75	67	60	52	44	

Q = Flow rate H = Total manometric head

Tolerance of characteristic curves in compliance with EN ISO 9906 App. A.

VLE (0.55÷1.1 kW)

POS.	COMPONENT	CONSTRUCTION CHARACTERISTICS				
1	SUCTION BODY	Stainless steel AISI 304, complete with threaded suction port in compliance with ISO 228/1				
2	EXTERNAL SLEEVE	Stainless steel AISI 304, complete with threaded delivery port in compliance with ISO 228/1				
3	MOTOR SLEEVE	Stainless steel AISI 304				
4	IMPELLERS AND DIFFUSERS	Noryl GFN2V				
5	DIAPHRAGMS	Stainless steel AISI 304, complete with anti-wear ring				
6	MOTOR SHAFT	Stainless steel EN 10088-3 - 1.4104				
7	TWO MECHANICAL SEALS SEPARATED BY AN OIL CHAMBER					
	<i>Seal</i>	<i>Shaft</i>	<i>Position</i>	<i>Materials</i>		
	<i>Model</i>	<i>Diameter</i>		<i>Stationary ring</i>	<i>Rotational ring</i>	<i>Elastomer</i>
	MG1-16	Ø 16 mm	Motor side	Silicon carbide	Graphite	NBR
	MG1-15 SIC	Ø 15 mm	Pump side	Silicon carbide	Silicon carbide	NBR
8	BEARINGS	6303 2RS - C3 / 6203 ZZ - C3				
9	CAPACITOR					
	<i>Pump</i>	<i>Capacitance</i>				
	<i>Single-phase</i>	<i>(230 V or 240 V)</i>	<i>(110 V)</i>			
	VLEm 2/2	16 µF 500 VL	30 µF 250 VL			
	VLEm 4/1	20 µF 500 VL	-			
	VLEm 2/3	25 µF 500 VL	-			
	VLEm 4/2	-	-			
	VLEm 2/4	-	-			
	VLEm 4/3	-	-			
10	ELECTRIC MOTOR					
	VLEm: single-phase 230 V - 50 Hz with built-in overload protector.					
	VLE: three-phase 400 V - 50 Hz.					
	- Insulation: F class.					
	- Protection: IP 68.					
11	POWER CABLE					
	2 metre long "H07 RN-F" cable					

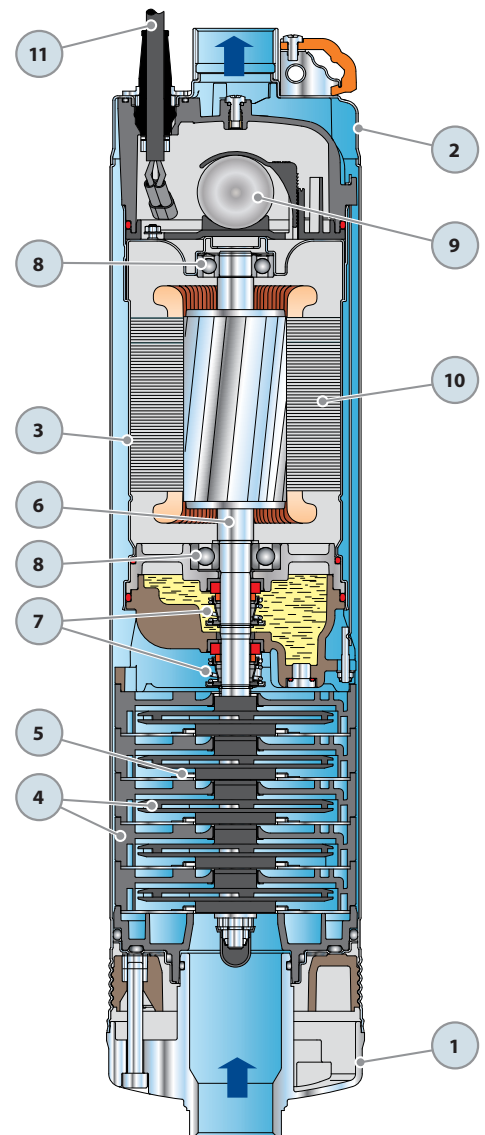

DIMENSIONS AND WEIGHT

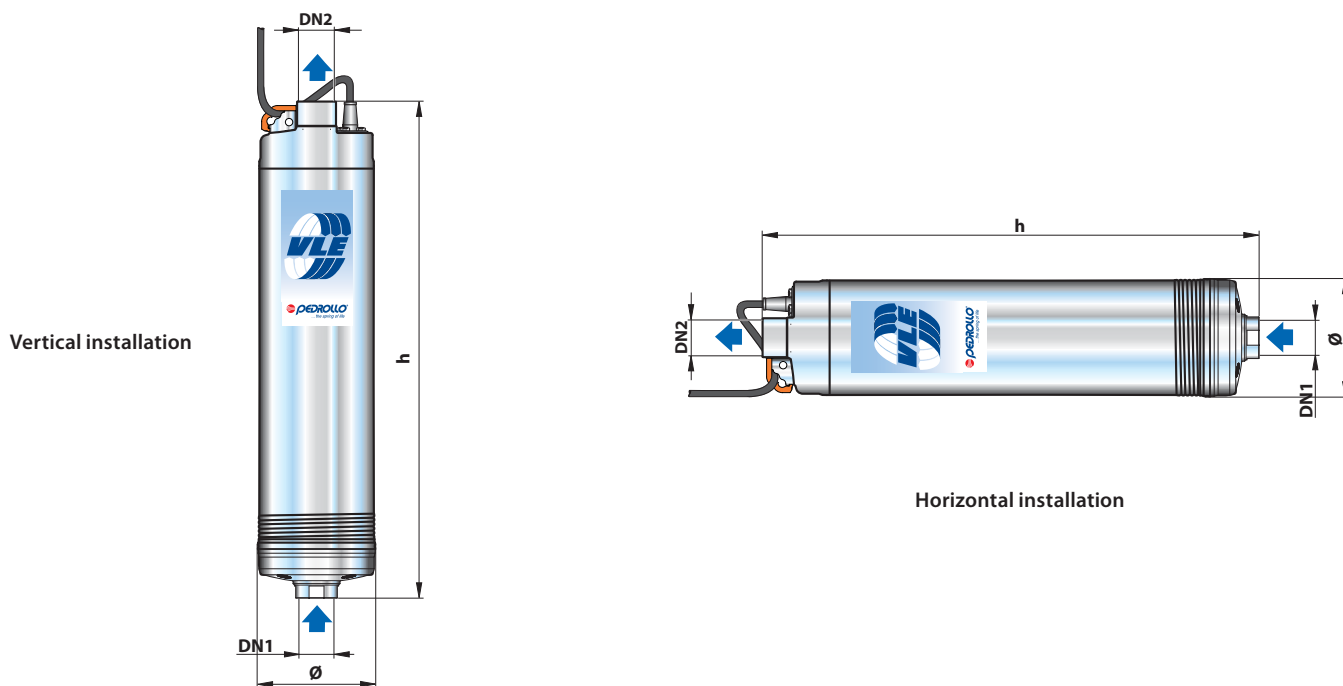

MODEL		PORTS		N° STAGES	DIMENSIONS mm		kg	
Single-phase	Three-phase	DN1	DN2		ø	h	1~	3~
VLEm 2/2 VLEm 4/1	–	1¼"	1¼"	4	135	546	14.0	–
VLEm 2/3 VLEm 4/2	–			5		600	16.0	–
–	VLE 2/3 VLE 4/2			7		570	–	14.6
VLEm 2/4 VLEm 4/3	VLE 2/4 VLE 4/3			–		648	18.1	16.8

ABSORPTION

MODEL	VOLTAGE (single-phase)		
	230 V	240 V	110 V
Single-phase	230 V	240 V	110 V
VLEm 2/2	5.0 A	5.0 A	10.0 A
VLEm 2/3	6.0 A	6.0 A	–
VLEm 2/4	7.5 A	7.5 A	–
VLEm 4/1	5.0 A	5.0 A	10.0 A
VLEm 4/2	6.0 A	6.0 A	–
VLEm 4/3	7.5 A	7.5 A	–

MODEL	VOLTAGE (three-phase)			
	230 V	400 V	240 V	415 V
Three-phase	230 V	400 V	240 V	415 V
VLE 2/3	4.5 A	2.6 A	4.5 A	2.6 A
VLE 2/4	5.2 A	3.0 A	5.2 A	3.0 A
VLE 4/2	4.5 A	2.6 A	4.5 A	2.6 A
VLE 4/3	5.2 A	3.0 A	5.2 A	3.0 A

PALLETIZATION

MODEL		GROUPAGE				CONTAINER			
Single-phase	Three-phase	n° pumps	H (mm)	kg		n° pumps	H (mm)	kg	
				1~	3~			1~	3~
VLEm 2/2 VLEm 4/1	–	36	1190	522	–	60	1890	859	–
VLEm 2/3 VLEm 4/2	–	25	869	417	–	40	1307	658	–
–	VLE 2/3 VLE 4/2	25	869	–	382	40	1307	–	601
VLEm 2/4 VLEm 4/3	VLE 2/4 VLE 4/3	25	869	470	437	40	1307	741	689

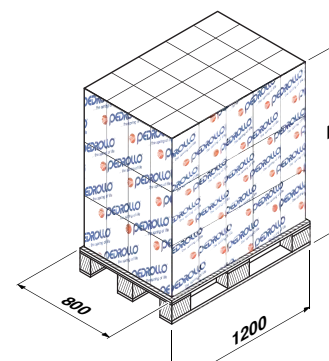

VLE (1.5÷2.2 kW)

POS.	COMPONENT	CONSTRUCTION CHARACTERISTICS				
1	PUMP BODY	Stainless steel AISI 304, complete with threaded suction port in compliance with ISO 228/1				
2	EXTERNAL SLEEVE	Stainless steel AISI 304, complete with threaded delivery port in compliance with ISO 228/1				
3	MOTOR SLEEVE	Stainless steel AISI 304				
4	IMPELLERS AND DIFFUSERS	Noryl GFN2V				
5	DIAPHRAGMS	Stainless steel AISI 304, complete with anti-wear ring				
6	MOTOR SHAFT	Stainless steel EN 10088-3 - 1.4104				
7	TWO MECHANICAL SEALS SEPARATED BY AN OIL CHAMBER					
	<i>Seal</i>	<i>Shaft</i>	<i>Position</i>	<i>Materials</i>		
	<i>Model</i>	<i>Diameter</i>		<i>Stationary ring</i>	<i>Rotational ring</i>	<i>Elastomer</i>
	MG1-19	Ø 19 mm	Motor side	Silicon carbide	Graphite	NBR
	MG1-18 SIC	Ø 18 mm	Pump side	Silicon carbide	Silicon carbide	NBR
8	BEARINGS	6304 2RS - C3 / 6203 ZZ - C3				
9	CAPACITOR					
	<i>Pump</i>	<i>Capacitance</i>				
	<i>Single-phase</i>	<i>(230 V or 240 V)</i>				
	VLEm 2/5	35 µF 450 VL				
	VLEm 4/4	50 µF 450 VL				
	VLEm 4/5	50 µF 450 VL				
10	ELECTRIC MOTOR					
	VLEm: single-phase 230 V - 50 Hz.		Windings up to 1.5 kW with built-in thermal overload protector.			
	⇒ The VLEm4/5 2.2 kW pump is equipped		with an external manual reset overload protector housed in the control box.			
	VLE: three-phase 400 V - 50 Hz.		– Insulation: F class.			
			– Protection: IP 68.			
11	POWER CABLE					
	2 metre long "H07 RN-F" cable with removable connector					
12	CONTROL BOX (for single-phase versions)					
	Complete with capacitor and power cable with Schuko plug					

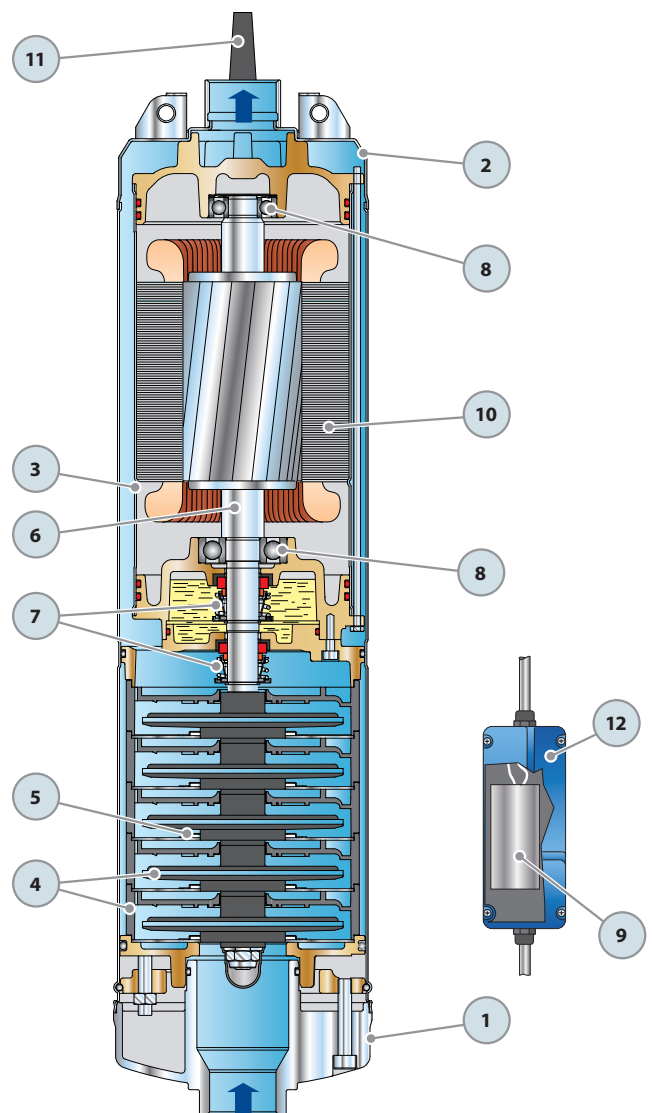

DIMENSIONS AND WEIGHT

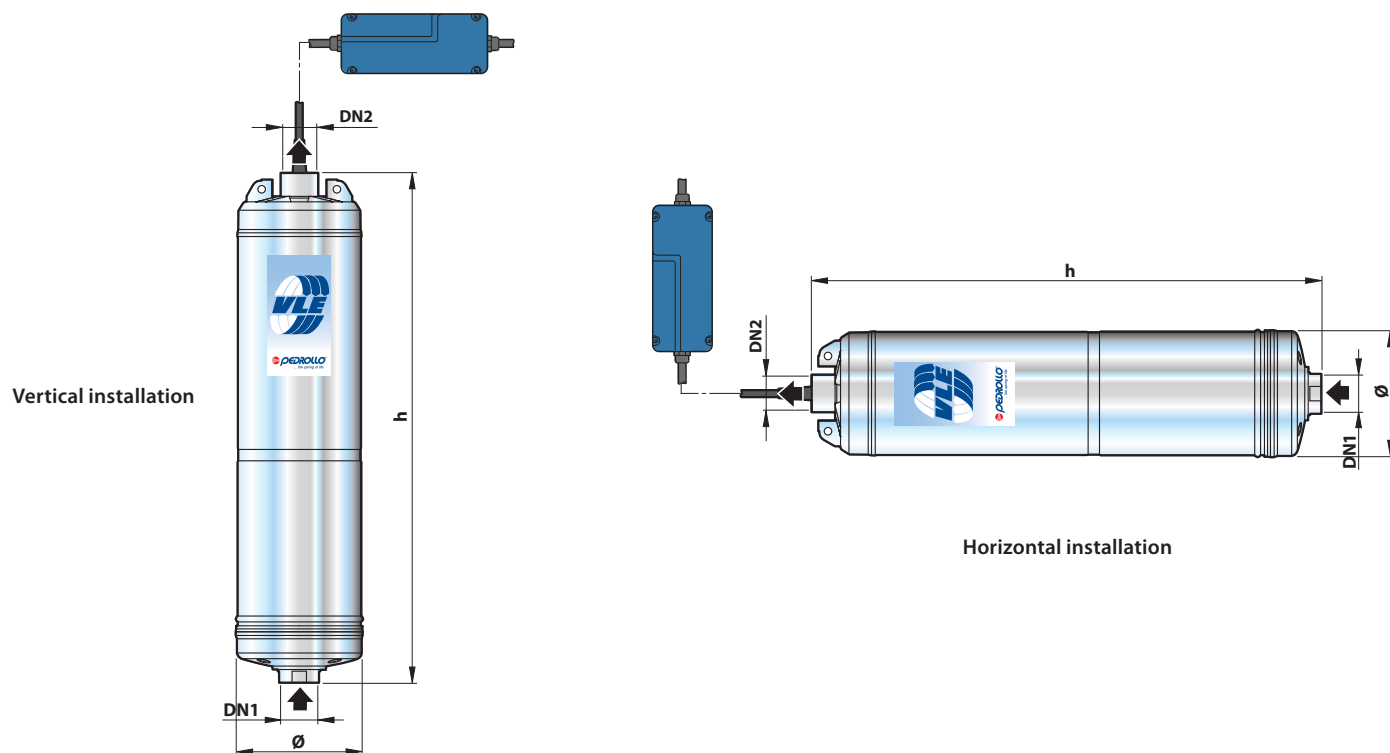

MODEL		PORTS		N° STAGES	DIMENSIONS mm		kg	
Single-phase	Three-phase	DN1	DN2		ø	h	1~	3~
VLEm 2/5	VLE 2/5	1 1/4"	1 1/4"	6	153	640	28.7	25.8
VLEm 4/4	VLE 4/4			5		610	28.0	26.4
VLEm 4/5	VLE 4/5			7		670	32.5	30.0

ABSORPTION

MODEL	VOLTAGE (single-phase)	
Single-phase	230 V	240 V
VLEm 2/5	9.0 A	9.0 A
VLEm 4/4	9.5 A	9.5 A
VLEm 4/5	14.0 A	14.0 A

MODEL	VOLTAGE (three-phase)			
Three-phase	230 V	400 V	240 V	415 V
VLE 2/5	6.2 A	3.6 A	6.2 A	3.6 A
VLE 4/4	6.2 A	3.6 A	6.2 A	3.6 A
VLE 4/5	8.5 A	4.9 A	8.5 A	4.9 A

PALLETIZATION

MODEL		GROUPAGE				CONTAINER			
Single-phase	Three-phase	n° pumps	H (mm)	kg		n° pumps	H (mm)	kg	
				1~	3~			1~	3~
VLEm 2/5	VLE 2/5	25	1340	734	662	40	2060	1165	1049
VLEm 4/4	VLE 4/4	25	1340	717	677	40	2060	1138	1073
VLEm 4/5	VLE 4/5	25	1340	830	766	40	2060	1317	1216

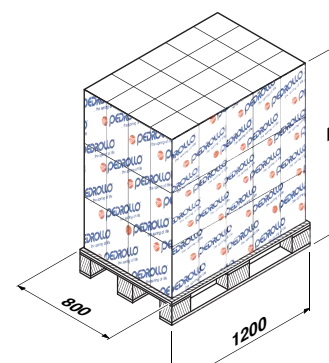

4SK

4" submersible pump with peripheral impellers



► Ready to install, stainless steel mono-block submersible pump.

Complete with:

- motor with built-in capacitor and thermal overload protector
- 20 m long power cable.



PERFORMANCE RANGE

- Flow rate up to **50 l/min** (3.0 m³/h)
- Head up to **68 m**

APPLICATION LIMITS

- Maximum liquid temperature **+40 °C**
- Maximum immersion depth of **40 m**
- Vertical and horizontal installation
- Continuous service **S1**

CONSTRUCTION AND SAFETY STANDARDS

EN 60335-1
IEC 60335-1
CEI 61-150

EN 60034-1
IEC 60034-1
CEI 2-3



CERTIFICATIONS



INSTALLATION AND USE

Suitable for use with **clean water that does not contain abrasive particles** and liquids that are not chemically aggressive towards the materials from which the pump is made.

As a result of their compact design and economy, they are suitable for domestic applications such as the distribution of water in combination with small pressure sets and for irrigation, etc.

PATENTS - TRADE MARKS - MODELS

- Patent Pending n° PCT/IB2009/051491, PCT/EP2009/059855
- Registered Community Design n° 342159-0009

OPTIONALS AVAILABLE ON REQUEST

- **30 m** long power cable
- Other voltages or 60 Hz frequency

GUARANTEE

1 year subject to terms and conditions

CHARACTERISTIC CURVES AND PERFORMANCE DATA

50 Hz n= 2900 1/min

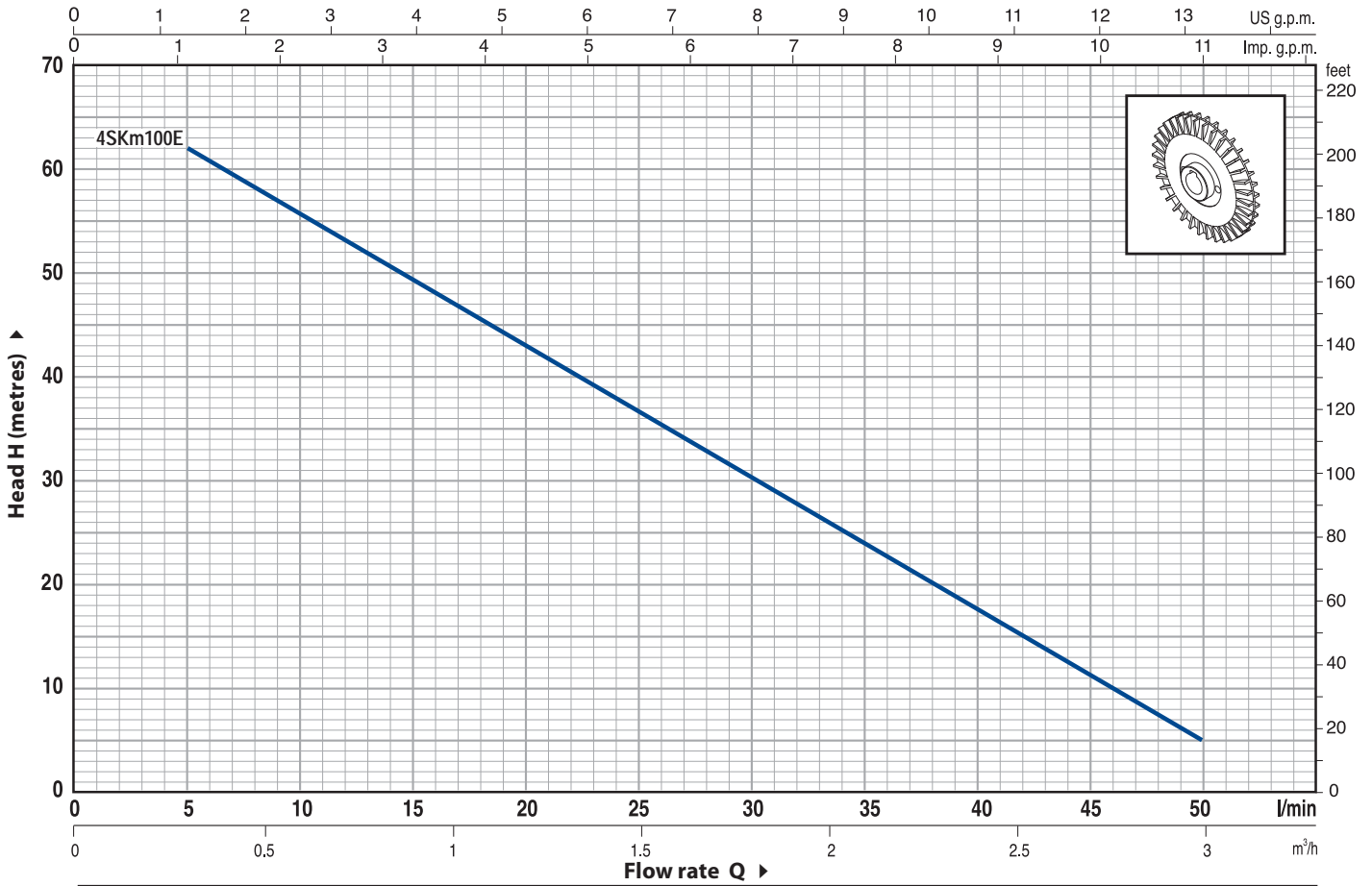

MODEL	POWER		Q	Flow rate										
	kW	HP		0	0.3	0.6	0.9	1.2	1.5	1.8	2.1	2.4	3.0	
Single-phase			Q	0	5	10	15	20	25	30	35	40	50	
4SKm 100E	0.75	1	H metres	68	62	55	49	43	37	30	24	17	5	

Q = Flow rate H = Total manometric head

Tolerance of characteristic curves in compliance with EN ISO 9906 App. A.

POS.	COMPONENT	CONSTRUCTION CHARACTERISTICS			
1	DELIVERY BODY	Stainless steel AISI 304, complete with threaded delivery port in compliance with ISO 228/1			
2	PUMP BODY	Brass, with (patented) double anti-seize inserts			
3	IMPELLER	Brass, with peripheral radial vanes			
4	MOTOR SLEEVE	Stainless steel AISI 304			
5	MOTOR SHAFT	Stainless steel EN 10088-3 - 1.4104			
6	SHAFT WITH DOUBLE SEAL AND OIL CHAMBER				
	<i>Seal</i>	<i>Shaft</i>			
	<i>Model</i>	<i>Diameter</i>	<i>Stationary ring</i>	<i>Rotational ring</i>	<i>Elastomer</i>
	MG1-16	Ø 16 mm	Silicon carbide	Graphite	NBR
7	LIP SEAL	Ø 17 x Ø 28 x H 7 mm			
8	BEARINGS	6203 ZZ - C3 / 6203 ZZ - C3			
9	CAPACITOR				
	<i>Capacitance</i>				
	<i>(230 V or 240 V)</i>	<i>(110 V)</i>			
	31.5 µF 500 VL	70 µF 250 VL			
10	ELECTRIC MOTOR				
	Submersible PEDROLLO motor, suitable for continuous duty (with dry, rewindable stator).				
	4SKm: single-phase 230 V - 50 Hz				
	Motor with built-in capacitor.				
	Thermal overload protector built-in to the winding.				
	– Insulation: F class.				
	– Protection: IP 68.				
11	POWER CABLE				
	➔ 20 metre long PBS-P cable for AD8 permanent immersion				
	NFC 15-100, ACS guaranteed for contact with drinking water				

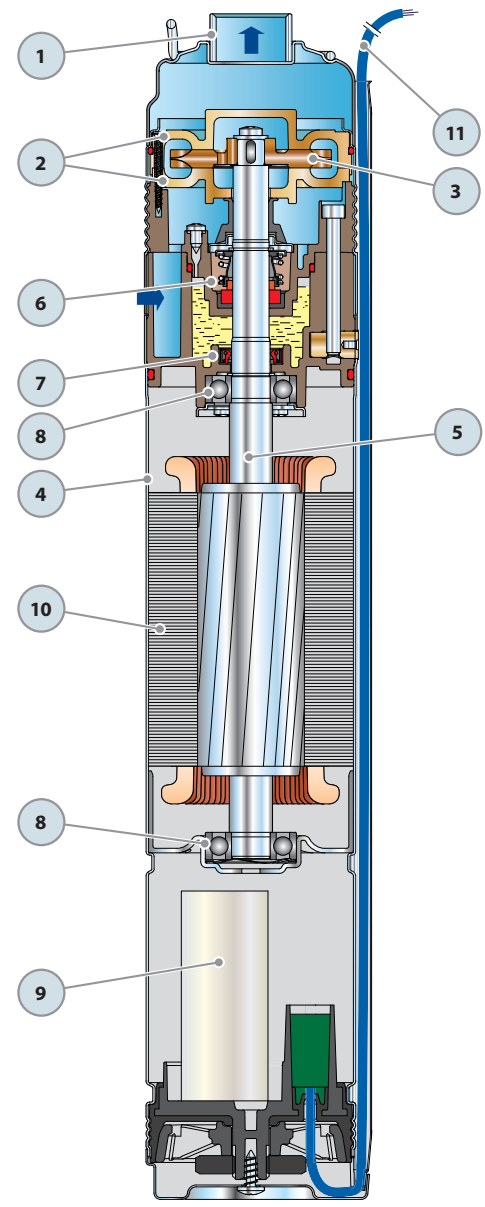

Patented

DIMENSIONS AND WEIGHT



Typical installation

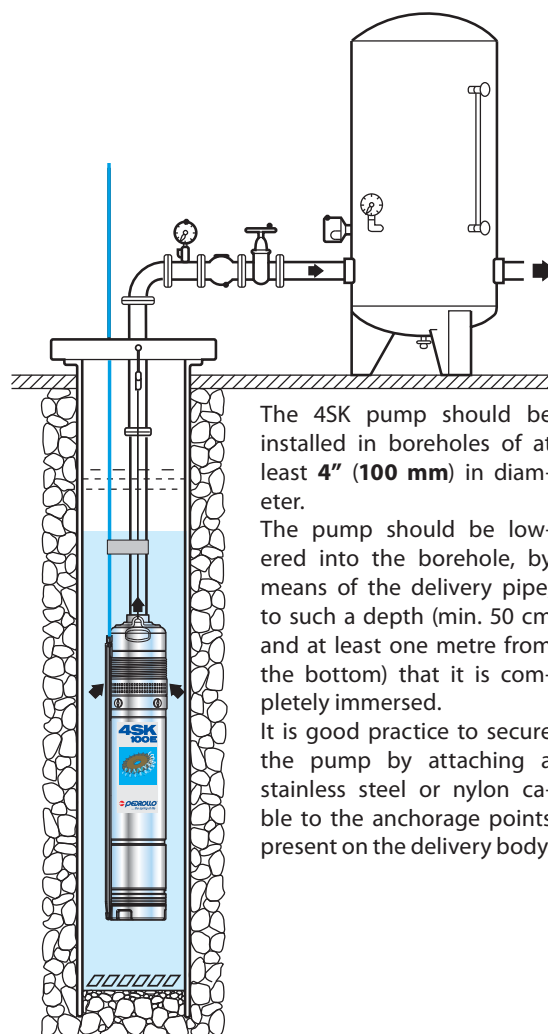

The 4SK pump should be installed in boreholes of at least **4" (100 mm)** in diameter.

The pump should be lowered into the borehole, by means of the delivery pipe, to such a depth (min. 50 cm and at least one metre from the bottom) that it is completely immersed.

It is good practice to secure the pump by attaching a stainless steel or nylon cable to the anchorage points present on the delivery body.

MODEL	PORT	DIMENSIONS mm		kg
		Ø	h	
Single-phase	DN			
4SKm 100E - 230 V	1"	99.5	521	12.3
4SKm 100E - 110 V			551	12.5

ABSORPTION

MODEL	VOLTAGE (single-phase)		
	230 V	240 V	110 V
Single-phase			
4SKm 100E	5.7 A	5.5 A	11.5 A

PALLETIZATION

MODEL	GROUPAGE			CONTAINER		
	n° pumps	H (mm)	kg 1~	n° pumps	H (mm)	kg 1~
Single-phase						
4SKm 100E - 230 V	48	110	607	72	1580	903
4SKm 100E - 110 V	48	110	617	72	1580	917

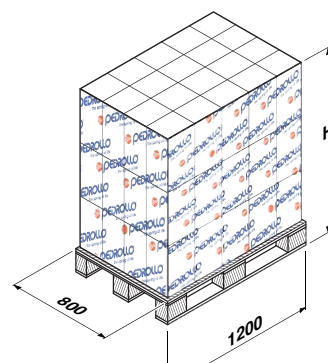

4BLOCK

4" monoblock submersible pump



► Ready to install, stainless steel monoblock submersible pump.

Complete with:

- motor with built-in capacitor and thermal overload protector
- 20 m long power cable.



PERFORMANCE RANGE

- Flow rate up to **150 l/min** (9 m³/h)
- Head up to **128 m**

APPLICATION LIMITS

- Maximum liquid temperature **+35 °C**
- Maximum sand content **150 g/m³**
- Maximum immersion depth of **60 m**
- Vertical and horizontal installation
- Starts/hour: 20 at regular intervals
- Continuous service **S1**

CONSTRUCTION AND SAFETY STANDARDS

EN 60335-1
IEC 60335-1
CEI 61-150

EN 60034-1
IEC 60034-1
CEI 2-3



CERTIFICATIONS



INSTALLATION AND USE

Suitable for pumping clean water from boreholes that contain sand (up to 150 g/m³).

As a result of their high efficiency and reliability they are suitable for use in domestic applications such as domestic water supply as part of a pressure supply and for irrigation, etc.

PATENTS - TRADE MARKS - MODELS

- Patent Pending n° PCT/IB2009/051491, PCT/EP2009/059855, BO2009A000650
- Registered Community Design n° 342159-0010

OPTIONALS AVAILABLE ON REQUEST

- **30 metre** long power cable
- Other voltages or 60 Hz frequency

GUARANTEE

1 year subject to terms and conditions

CHARACTERISTIC CURVES AND PERFORMANCE DATA

50 Hz n= 2900 1/min

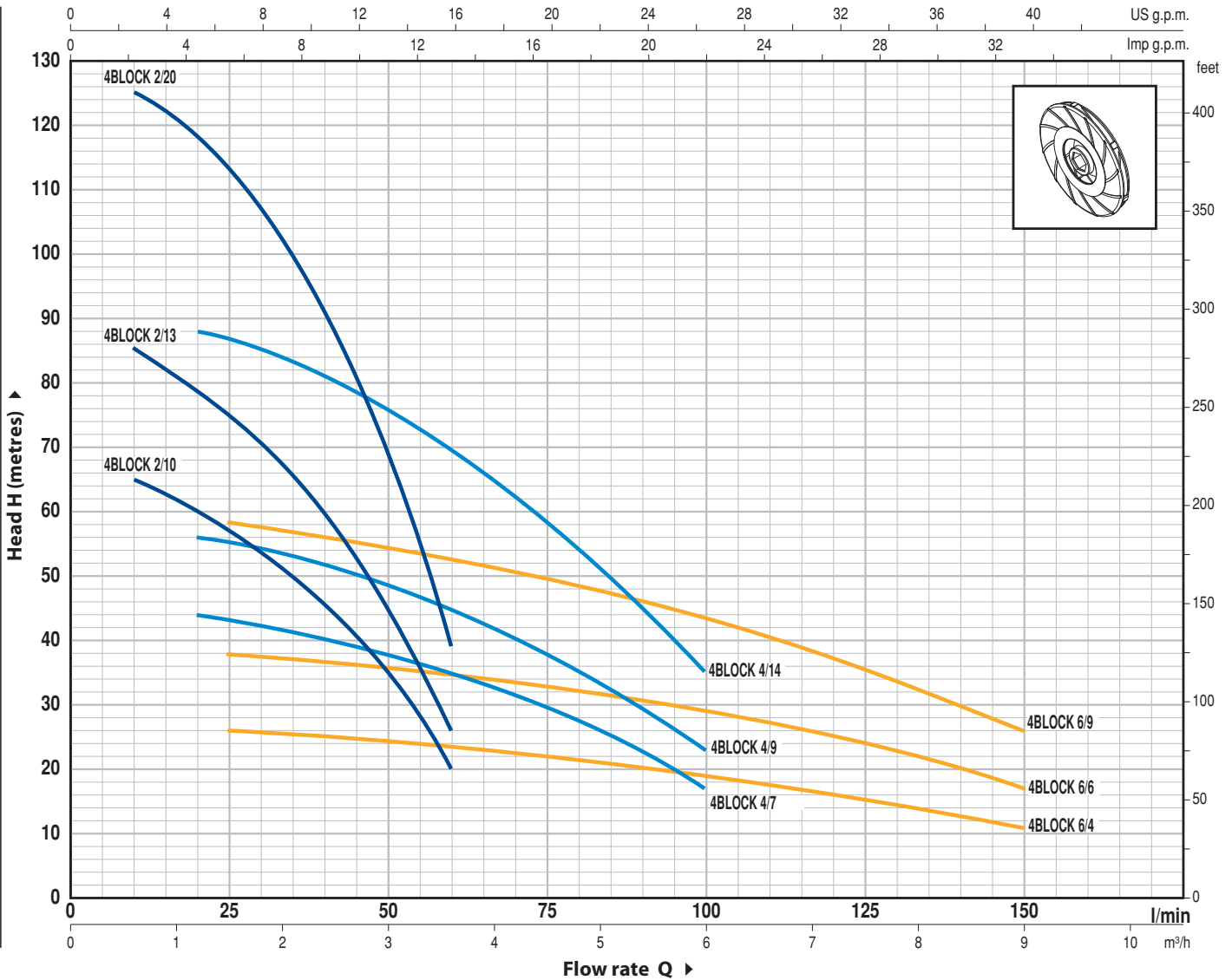

MODEL		POWER		Q	Flow rate							
Single-phase	Three-phase	kW	HP		m³/h	0	0.6	1.2	1.8	2.4	3.0	3.6
4BLOCKm 2/10	4BLOCK 2/10	0.55	0.75	H metres	0	10	20	30	40	50	60	
4BLOCKm 2/13	4BLOCK 2/13	0.75	1		66	65	60	54	46	35	20	
4BLOCKm 2/20	4BLOCK 2/20	1.1	1.5		86	85	79	71	60	45	26	
					l/min	0	10	20	30	40	50	60

MODEL		POWER		Q	Flow rate										
Single-phase	Three-phase	kW	HP		m³/h	0	1.2	1.8	2.4	3.0	3.6	4.2	4.8	5.4	6.0
4BLOCKm 4/7	4BLOCK 4/7	0.55	0.75	H metres	0	20	30	40	50	60	70	80	90	100	
4BLOCKm 4/9	4BLOCK 4/9	0.75	1		46	44	42	40	38	35	31.5	27	23	17	
4BLOCKm 4/14	4BLOCK 4/14	1.1	1.5		60	56	54.5	52	49	45	40.5	35	29	23	
					l/min	0	20	30	40	50	60	70	80	90	100

MODEL		POWER		Q	Flow rate							
Single-phase	Three-phase	kW	HP		m³/h	0	1.5	3.0	4.5	6.0	7.5	9.0
4BLOCKm 6/4	4BLOCK 6/4	0.55	0.75	H metres	0	25	50	75	100	125	150	
4BLOCKm 6/6	4BLOCK 6/6	0.75	1		27	26	24	22	19	15	11	
4BLOCKm 6/9	4BLOCK 6/9	1.1	1.5		40	38	36	33	29	24	17	
					l/min	0	25	50	75	100	125	150

Q = Flow rate H = Total manometric head

Tolerance of characteristic curves in compliance with EN ISO 9906 App. A.

POS.	DESCRIPTION	CONSTRUCTION CHARACTERISTICS				
1	DELIVERY BODY AND EXTERNAL SLEEVE	Stainless steel AISI 304, complete with threaded delivery port in compliance with ISO 228/1.				
2	IMPELLERS	Lexan 141-R				
3	DIFFUSERS	Noryl GFN2V				
4	STAGE CASING	Stainless steel AISI 304				
5	PUMP SHAFT	Stainless steel AISI 304				
6	PUMP BEARINGS	Special-technopolymer housing with stainless steel AISI 316, chrome oxide coated, sand resistant shaft bushing.				
7	DRIVE COUPLING	Stainless steel AISI 316L				
8	CABLE COVER	Stainless steel AISI 304				
9	MOTOR SHAFT	Stainless steel EN 10088-3 1.4104 (AISI 431 for single-phase 1.1 kW)				
10	MOTOR SLEEVE	Stainless steel AISI 304				
11	TWO MECHANICAL SEALS SEPARATED BY AN OIL CHAMBER					
	Seal	Shaft	Position	Materials		
	<i>Model</i>	<i>Diameter</i>		<i>Stationary ring</i>	<i>Rotational ring</i>	<i>Elastomer</i>
	MG1-17	Ø 17 mm	Motor side	Silicon carbide	Graphite	NBR
	MG1-16 SIC	Ø 16 mm	Pump side	Silicon carbide	Silicon carbide	NBR
12	BEARINGS					
	Pump	Model				
	4BLOCK – 0.55÷0.75 kW	6203 ZZ - C3 / 6203 ZZ - C3				
	4BLOCK – 1.1 kW	3203B ZZ - C3 / 6203 ZZ - C3				
13	CAPACITOR					
	Pump	Capacitance				
	<i>Single-phase</i>	<i>(230 V or 240 V)</i>				
	4BLOCK – 0.55 kW	20 µF 500 VL				
	4BLOCK – 0.75 kW	31.5 µF 500 VL				
	4BLOCK – 1.1 kW	35 µF 500 VL				
14	ELECTRIC MOTOR					
	Submersible PEDROLLO motor, suitable for continuous duty (with dry, rewindable stator).					
	4BLOCKm: single-phase 230 V - 50 Hz Motor with built-in capacitor. Thermal overload protector built-in to the winding.					
	4BLOCK: three-phase 400 V - 50 Hz					
	– Insulation: F class.					
	– Protection: IP 68.					
15	POWER CABLE					
	➔ 20 metre long PBS-P cable for AD8 permanent immersion NF C 15-100, ACS guaranteed for contact with drinking water					

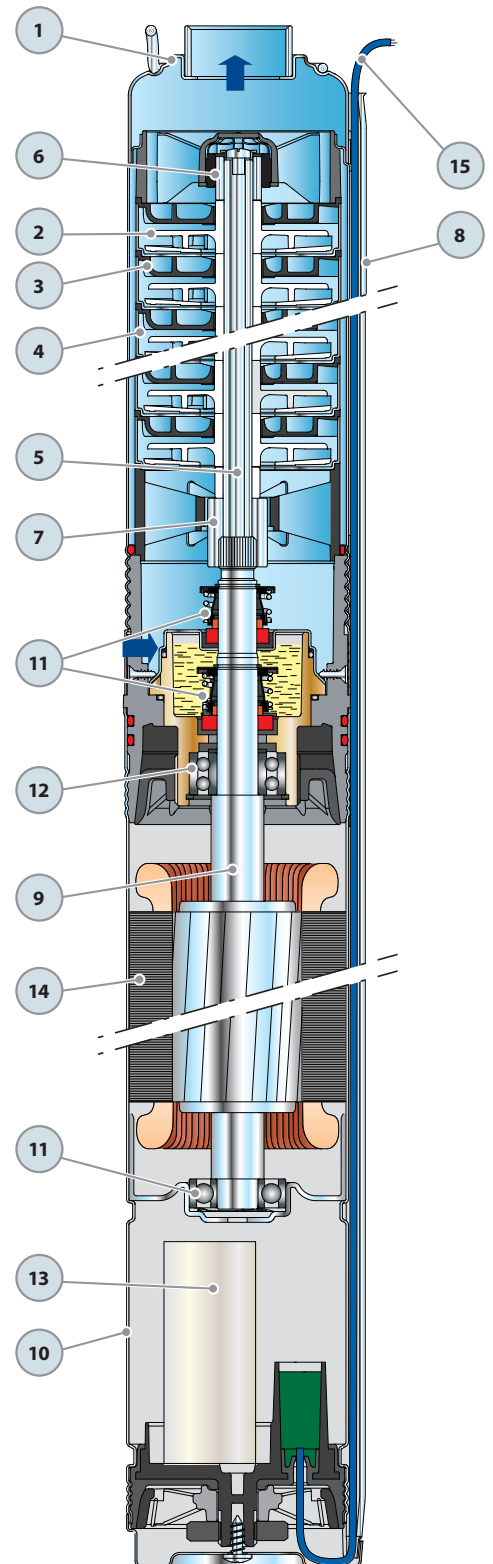

Patented

DIMENSIONS AND WEIGHT

MODEL		PORT DN	DIMENSIONS mm			kg	
Single-phase	Three-phase		N° STAGES	Ø	h	1~	3~
4BLOCKm 2/10	4BLOCK 2/10	1½"	10	100	720-695	12.5	11.9
4BLOCKm 2/13	4BLOCK 2/13		13		801-776	14.3	13.7
4BLOCKm 2/20	4BLOCK 2/20		20		1001-930	17.8	16.1
4BLOCKm 4/7	4BLOCK 4/7		7		689-664	12.1	11.4
4BLOCKm 4/9	4BLOCK 4/9		9		758-733	13.8	13.2
4BLOCKm 4/14	4BLOCK 4/14		14		940-868	17.0	15.1
4BLOCKm 6/4	4BLOCK 6/4		4		655-630	10.7	9.7
4BLOCKm 6/6	4BLOCK 6/6		6		740-715	13.3	11.3
4BLOCKm 6/9	4BLOCK 6/9		9		902-823	16.5	13.9

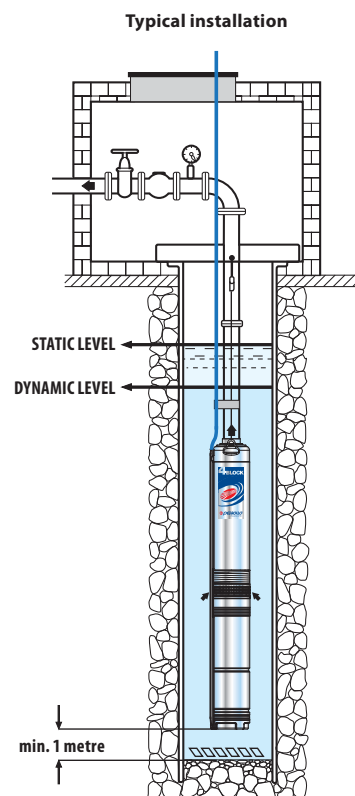
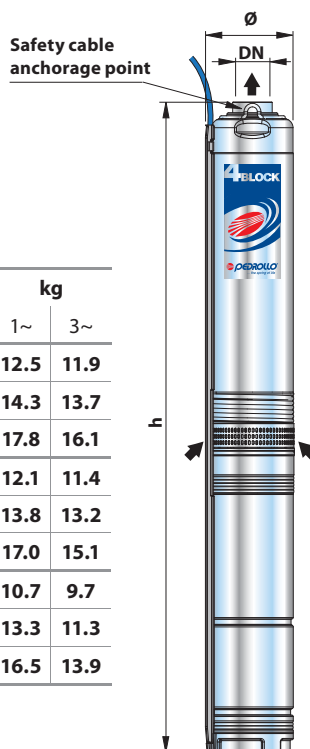

ABSORPTION

MODEL	VOLTAGE (single-phase)	
	230 V	240 V
Single-phase	230 V	240 V
4BLOCKm - 0.55 kW	5.0 A	5.0 A
4BLOCKm - 0.75 kW	6.0 A	6.0 A
4BLOCKm - 1.1 kW	8.0 A	8.0 A

MODEL	VOLTAGE (three-phase)			
	230 V	400 V	240 V	415 V
Three-phase	230 V	400 V	240 V	415 V
4BLOCK - 0.55 kW	2.8 A	1.6 A	2.8 A	1.6 A
4BLOCK - 0.75 kW	3.5 A	2.0 A	3.5 A	2.0 A
4BLOCK - 1.1 kW	4.7 A	2.7 A	4.7 A	2.7 A

PALLETIZATION

MODEL		GROUPAGE			CONTAINER				
Single-phase	Threw	n° pumps	H (mm)	kg		n° pumps	H (mm)	kg	
				1~	3~			1~	3~
4BLOCKm 2/10	4BLOCK 2/10	72	1484	914	877	108	2156	1362	1307
4BLOCKm 2/13	4BLOCK 2/13	52	1570	759	730	72	2120	1044	1004
4BLOCKm 2/20	4BLOCK 2/20	52	1570	944	852	72	2120	1300	1173
4BLOCKm 4/7	4BLOCK 4/7	72	1484	891	839	108	2156	1328	1250
4BLOCKm 4/9	4BLOCK 4/9	52	1570	737	701	72	2120	1013	964
4BLOCKm 4/14	4BLOCK 4/14	52	1570	902	803	72	2120	1242	1105
4BLOCKm 6/4	4BLOCK 6/4	72	1484	785	715	108	2156	1169	1065
4BLOCKm 6/6	4BLOCK 6/6	72	1484	977	831	108	2156	1458	1237
4BLOCKm 6/9	4BLOCK 6/9	52	1570	873	740	72	2120	1202	1018

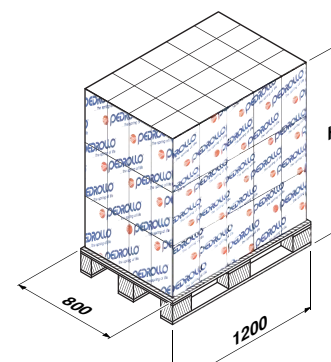

4SR

4" submersible pumps



PERFORMANCE RANGE

- Flow rate up to **375 l/min** (22.5 m³/h)
- Head up to **405 m**

APPLICATION LIMITS

- Maximum liquid temperature **+35 °C**
- Maximum sand content **150 g/m³**
- **100 m** immersion limit
- Installation:
 - vertical
 - horizontal, with the following limits:
 - 4SR1 - 4SR1.5 - 4SR2 - 4SR4 up to **27 stages**
 - 4SR6 - 4SR8 - 4SR10 - 4SR12 - 4SR15 up to **17 stages**
- Starts/hour: 20 at regular intervals
- Minimum flow rate for motor cooling **8 cm/s**
- Continuous service **S1**

CONSTRUCTION AND SAFETY STANDARDS

ELECTRIC MOTOR

- Single-phase 230 V - 50 Hz
- Three-phase 400 V - 50 Hz

Length of power cable:

- **1.5 m** for powers from 0.37 to 3 kW
- **2.5 m** for powers from 4 to 5.5 kW (7.5 kW 4SR-FK)
- **3.5 m** for power from 7.5 kW 4SR-PD

⇒ The **4SR-PD** single-phase versions come with a capacitor included in the packaging.

EN 60335-1
IEC 60335-1
CEI 61-150

EN 60034-1
IEC 60034-1
CEI 2-3



CERTIFICATIONS



AM30

YspTECT-003

INSTALLATION AND USE

Suitable for use with clean water with a sand content of no more than **150 g/m³**. As a result of their high efficiency and reliability, they are suitable for use in domestic, civil and industrial applications such as for the distribution of water in combination with pressure sets, for irrigation, for washing plants and for pressure boosting in fire-fighting sets, etc.

PATENTS - TRADE MARKS - MODELS

- Patent Pending n° PCT/EP2009/059855 (cable cover)
- Patent Pending n° PCT/IB2009/051491 (for single-phase 4SR-PD up to 0.75 kW; three-phase up to 1.1 kW).

OPTIONALS AVAILABLE ON REQUEST

- Other voltages or 60 Hz frequency

GUARANTEE

1 year subject to terms and conditions

PERFORMANCE RANGE

50 Hz n= 2900 1/min

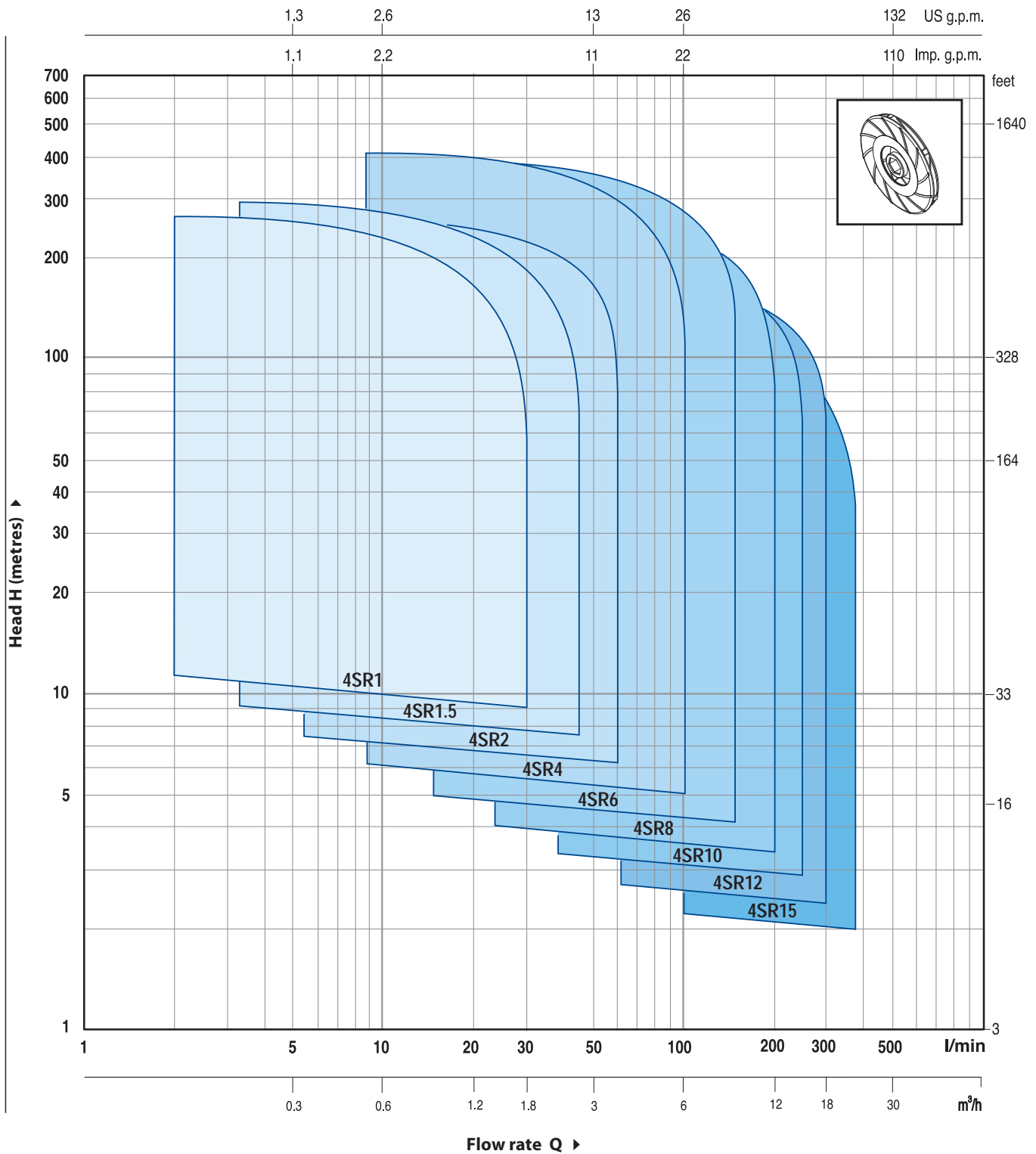

DESCRIPTION

4 SR 1 m / 13 - PD or FK or HYD

- Borehole diameter in inches _____
- Series _____
- Flow rate in m³/h at the point of highest efficiency _____
- Single-phase motor _____
- Number of stages _____
- PD:** pump with "PEDROLLO" motor _____
- FK:** pump with "FRANKLIN" motor _____
- HYD:** pump without motor _____

CHARACTERISTIC CURVES AND PERFORMANCE DATA

50 Hz n= 2900 1/min

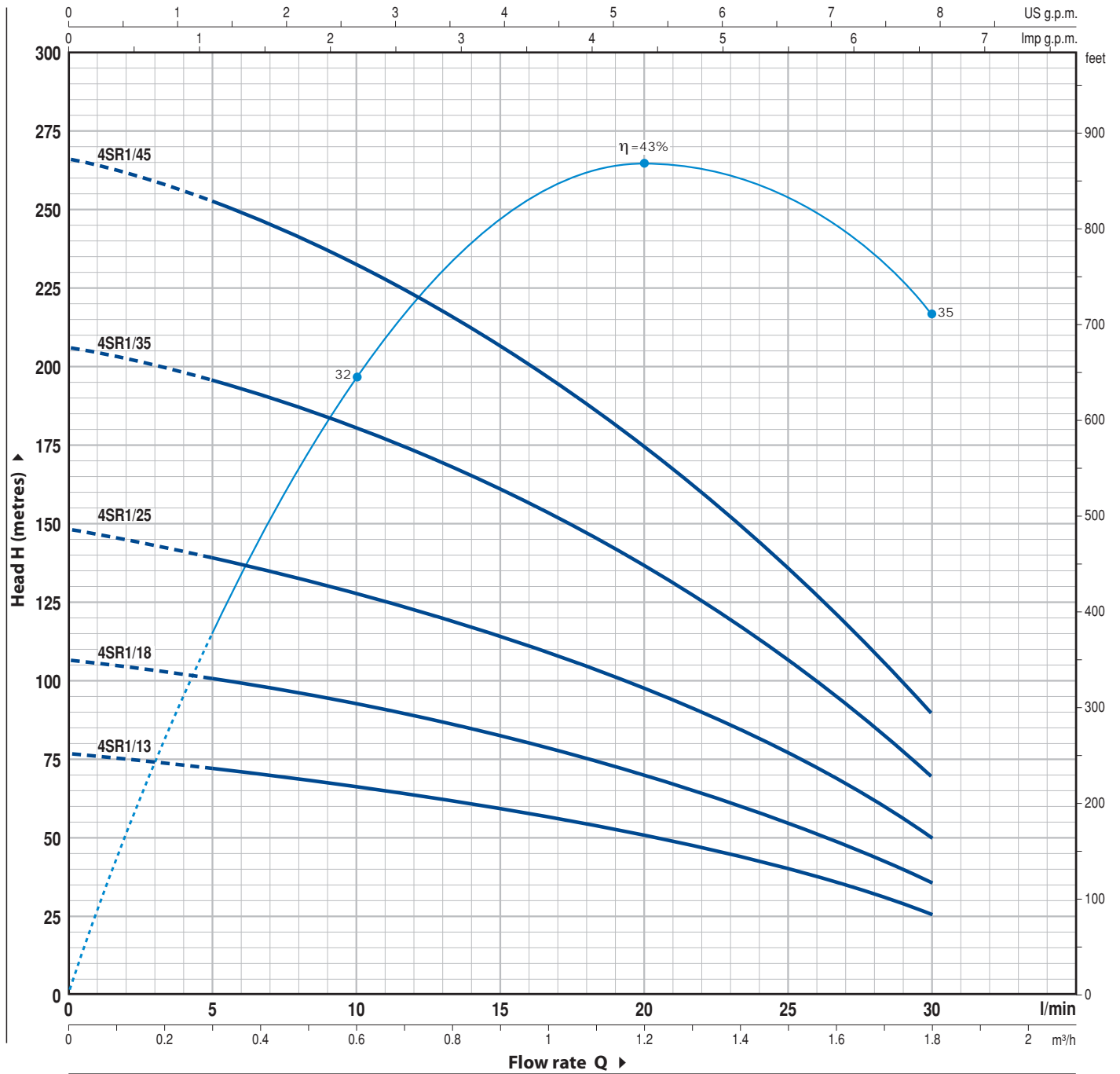

MODEL		POWER		Q	Flow rate						
Single-phase	Three-phase	kW	HP		0	0.3	0.6	0.9	1.2	1.5	1.8
4SR1m/13	4SR1/13	0.37	0.50	H metres	0	5	10	15	20	25	30
4SR1m/18	4SR1/18	0.55	0.75		77	73	67	60	51	40	26
4SR1m/25	4SR1/25	0.75	1		107	101	93	83	71	55	36
4SR1m/35	4SR1/35	1.1	1.5		148	140	129	115	98	77	50
4SR1m/45	4SR1/45	1.5	2		206	197	182	161	136	107	70
					266	254	234	207	176	137	90

Q = Flow rate H = Total manometric head

Tolerance of characteristic curves in compliance with EN ISO 9906 App. A.

CHARACTERISTIC CURVES AND PERFORMANCE DATA

50 Hz n = 2900 1/min

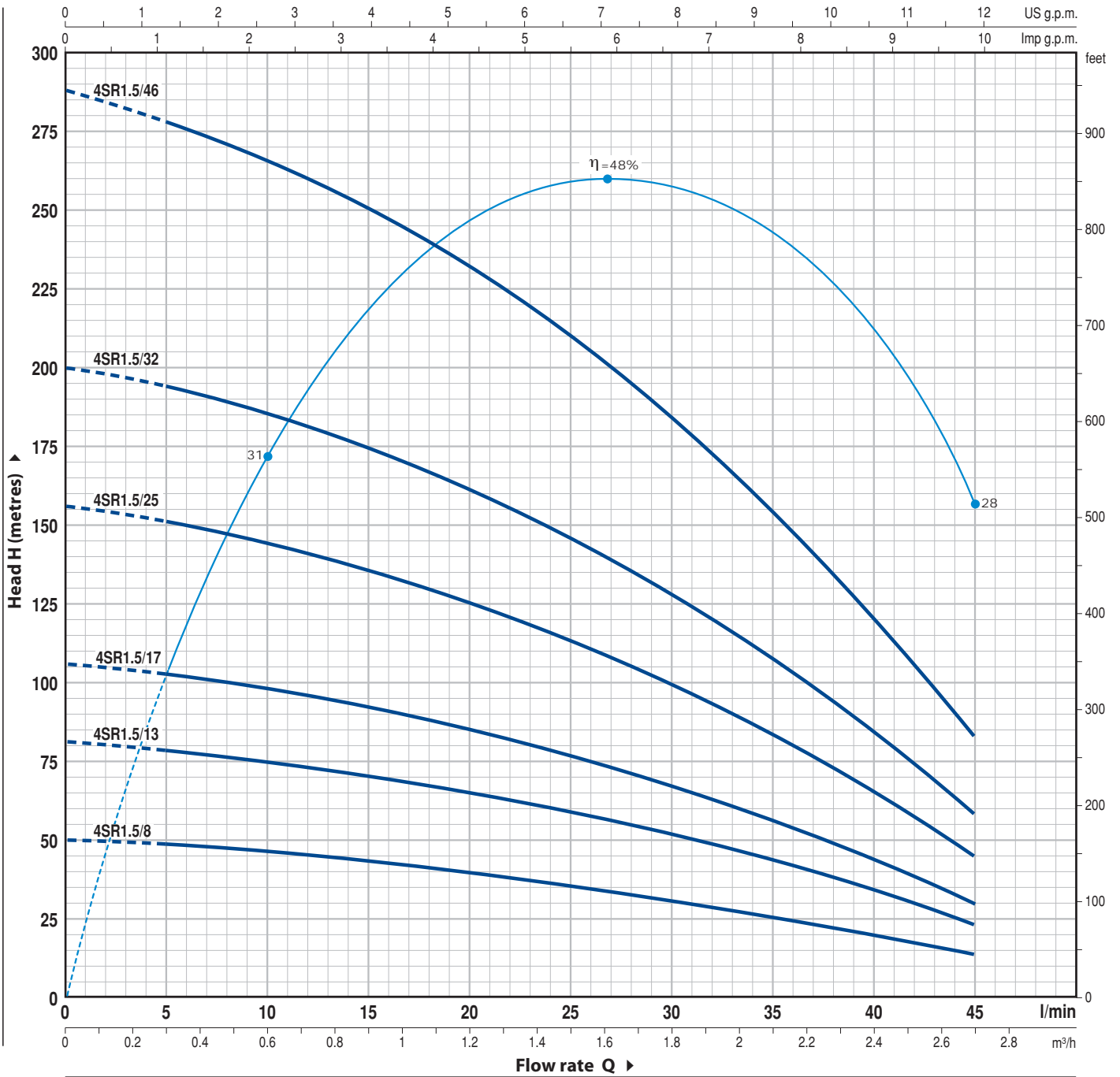

MODEL		POWER		Q	Flow rate (l/min)												
Single-phase	Three-phase	kW	HP		0	5	10	15	20	25	30	35	40	45			
4SR1.5m/8	4SR1.5/8	0.37	0.50	H metres	50	48	46	44	40	36	32	26	20	14			
4SR1.5m/13	4SR1.5/13	0.55	0.75		81	78	75	71	66	59	52	43	33	23			
4SR1.5m/17	4SR1.5/17	0.75	1		106	102	98	93	86	78	68	56	43	30			
4SR1.5m/25	4SR1.5/25	1.1	1.5		156	151	144	136	127	115	100	83	64	45			
4SR1.5m/32	4SR1.5/32	1.5	2		200	193	184	175	162	147	128	106	82	58			
4SR1.5m/46	4SR1.5/46	2.2	3		288	277	265	250	233	211	184	153	117	83			

Q = Flow rate H = Total manometric head

Tolerance of characteristic curves in compliance with EN ISO 9906 App. A.

4SR2

CHARACTERISTIC CURVES AND PERFORMANCE DATA

50 Hz n= 2900 1/min

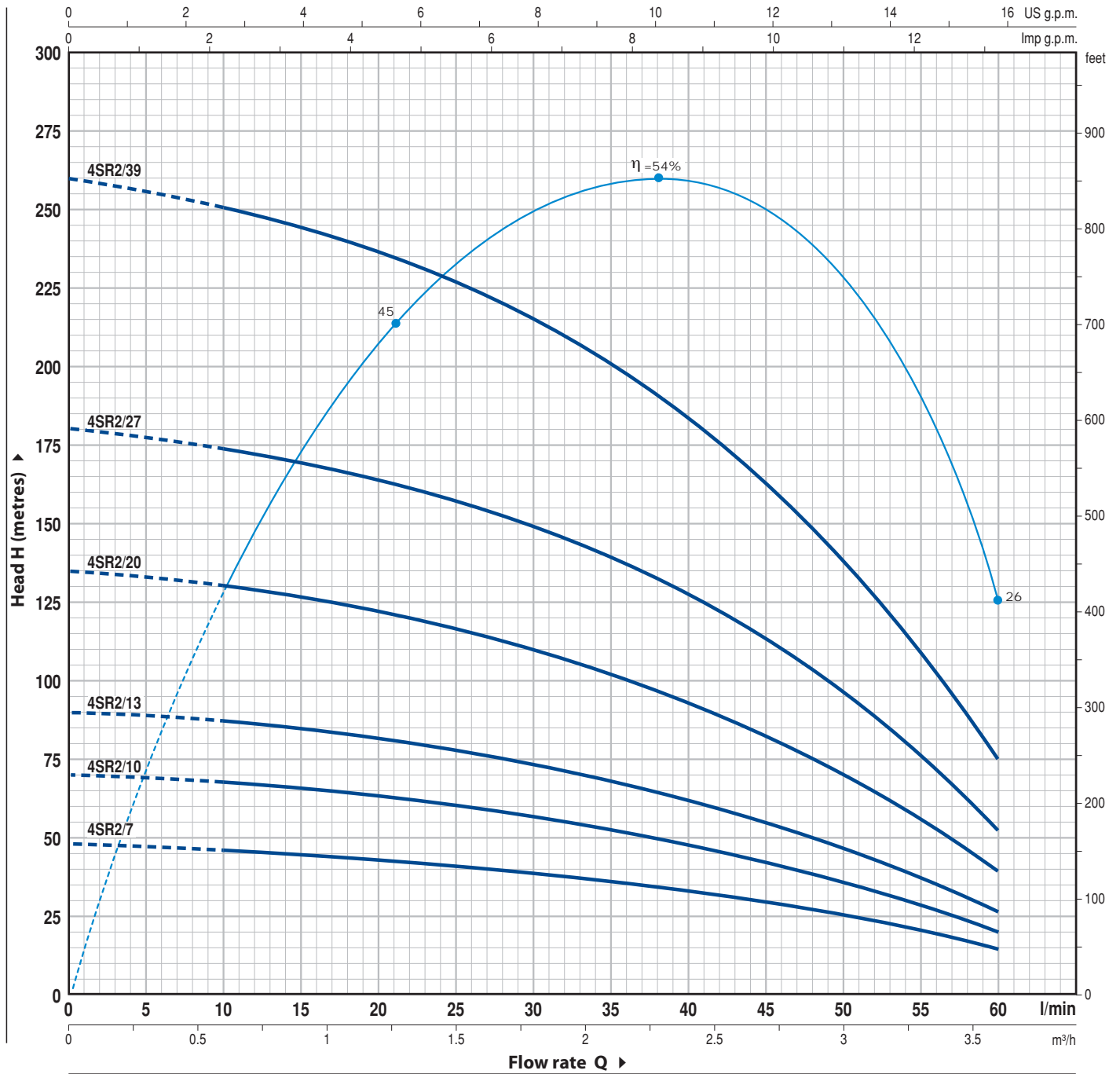

MODEL		POWER		Q	H metres						
Single-phase	Three-phase	kW	HP		0	0.6	1.2	1.8	2.4	3.0	3.6
4SR2m/7	4SR2/7	0.37	0.50	0	0	10	20	30	40	50	60
				48	48	46	44	39	33	25	14
				70	70	68	63	57	48	36	20
				90	90	88	82	74	62	46	26
				135	135	130	122	111	93	71	39
				180	180	173	164	150	126	96	52
				260	260	250	238	216	183	138	75

Q = Flow rate H = Total manometric head

Tolerance of characteristic curves in compliance with EN ISO 9906 App. A.

CHARACTERISTIC CURVES AND PERFORMANCE DATA

50 Hz n = 2900 1/min

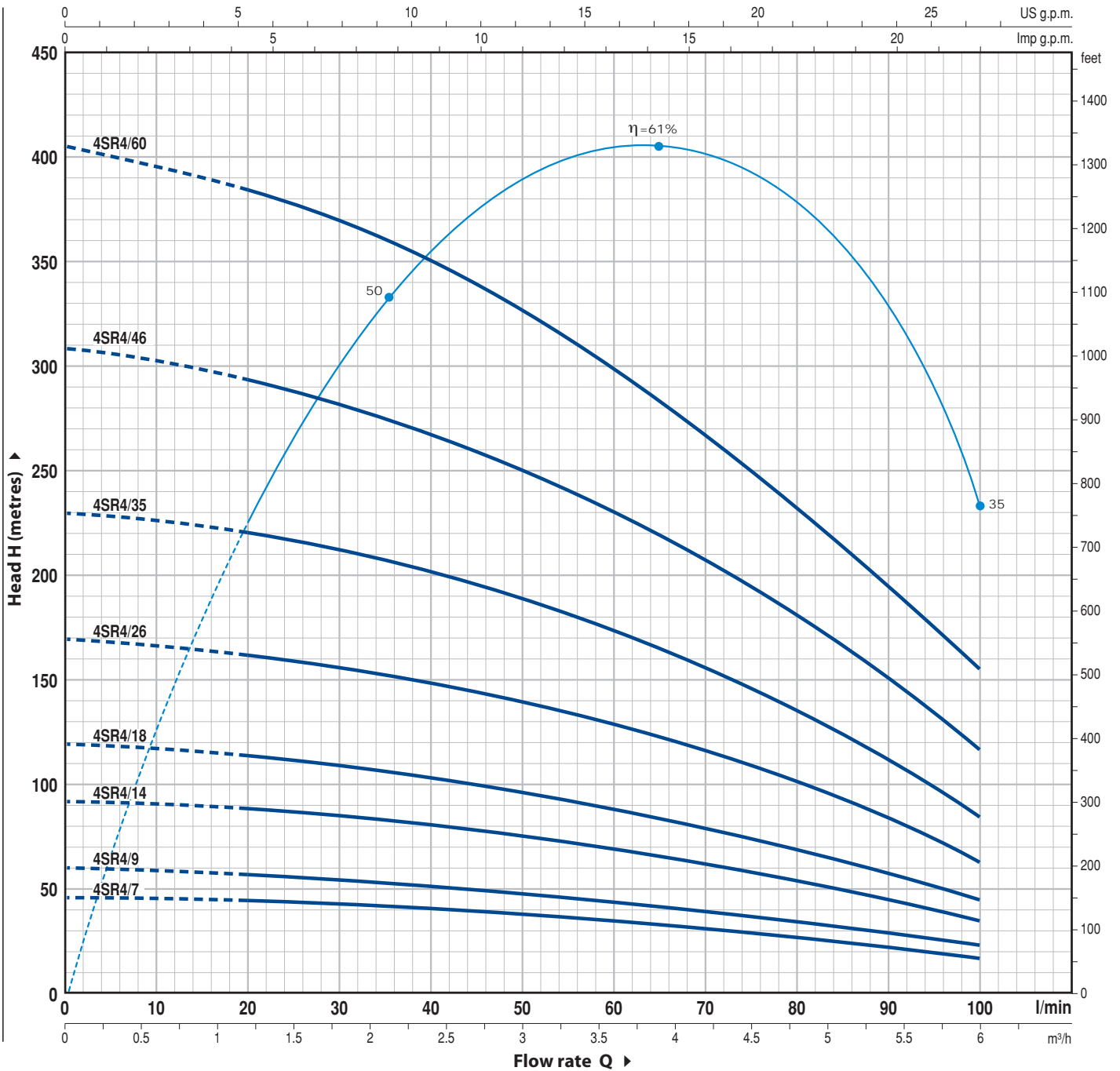

MODEL		POWER		Q	H metres									
Single-phase	Three-phase	kW	HP		0	1.2	1.8	2.4	3.0	3.6	4.2	4.8	5.4	6.0
				l/min	0	20	30	40	50	60	70	80	90	100
4SR4m/7	4SR4/7	0.55	0.75	46	44	42	40	38	35	32	28	23	17	
4SR4m/9	4SR4/9	0.75	1	60	56	55	52	49	45	40	35	29	23	
4SR4m/14	4SR4/14	1.1	1.5	92	88	85	81	76	70	63	55	45	35	
4SR4m/18	4SR4/18	1.5	2	120	112	109	104	98	90	81	70	58	45	
4SR4m/26	4SR4/26	2.2	3	170	162	157	150	141	130	116	101	84	63	
-	4SR4/35	3	4	230	220	211	202	190	175	157	137	113	85	
-	4SR4/46	4	5.5	308	293	280	269	249	230	205	181	151	117	
-	4SR4/60	5.5	7.5	405	385	370	350	325	300	270	235	195	155	

Q = Flow rate H = Total manometric head

Tolerance of characteristic curves in compliance with EN ISO 9906 App. A.

4SR6

CHARACTERISTIC CURVES AND PERFORMANCE DATA

50 Hz n= 2900 1/min

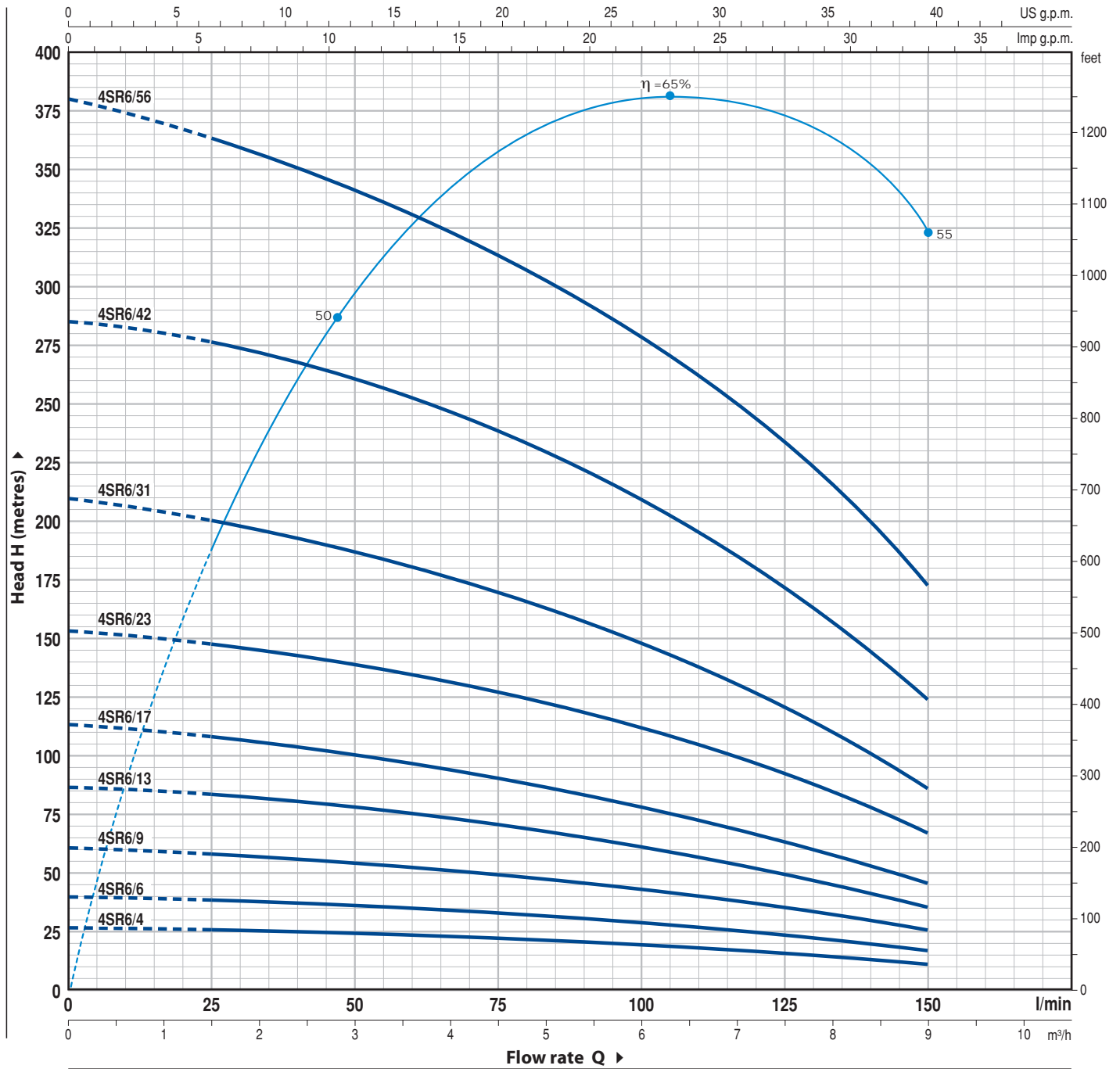

MODEL		POWER		Q	H metres						
Single-phase	Three-phase	kW	HP		0	1.5	3.0	4.5	6.0	7.5	9.0
				0	0	25	50	75	100	125	150
4SR6m/4	4SR6/4	0.55	0.75	27	27	26	24	22	19	15	11
4SR6m/6	4SR6/6	0.75	1	40	40	38	36	33	29	24	17
4SR6m/9	4SR6/9	1.1	1.5	61	61	58	54	50	44	35	26
4SR6m/13	4SR6/13	1.5	2	87	87	83	78	71	61	49	35
4SR6m/17	4SR6/17	2.2	3	114	114	107	100	91	79	62	45
-	4SR6/23	3	4	154	154	148	138	128	112	92	67
-	4SR6/31	4	5.5	210	210	200	186	170	149	121	86
-	4SR6/42	5.5	7.5	285	285	276	258	240	212	170	124
-	4SR6/56	7.5	10	380	380	365	340	315	280	233	173

Q = Flow rate H = Total manometric head

Tolerance of characteristic curves in compliance with EN ISO 9906 App. A.

CHARACTERISTIC CURVES AND PERFORMANCE DATA

50 Hz n = 2900 1/min

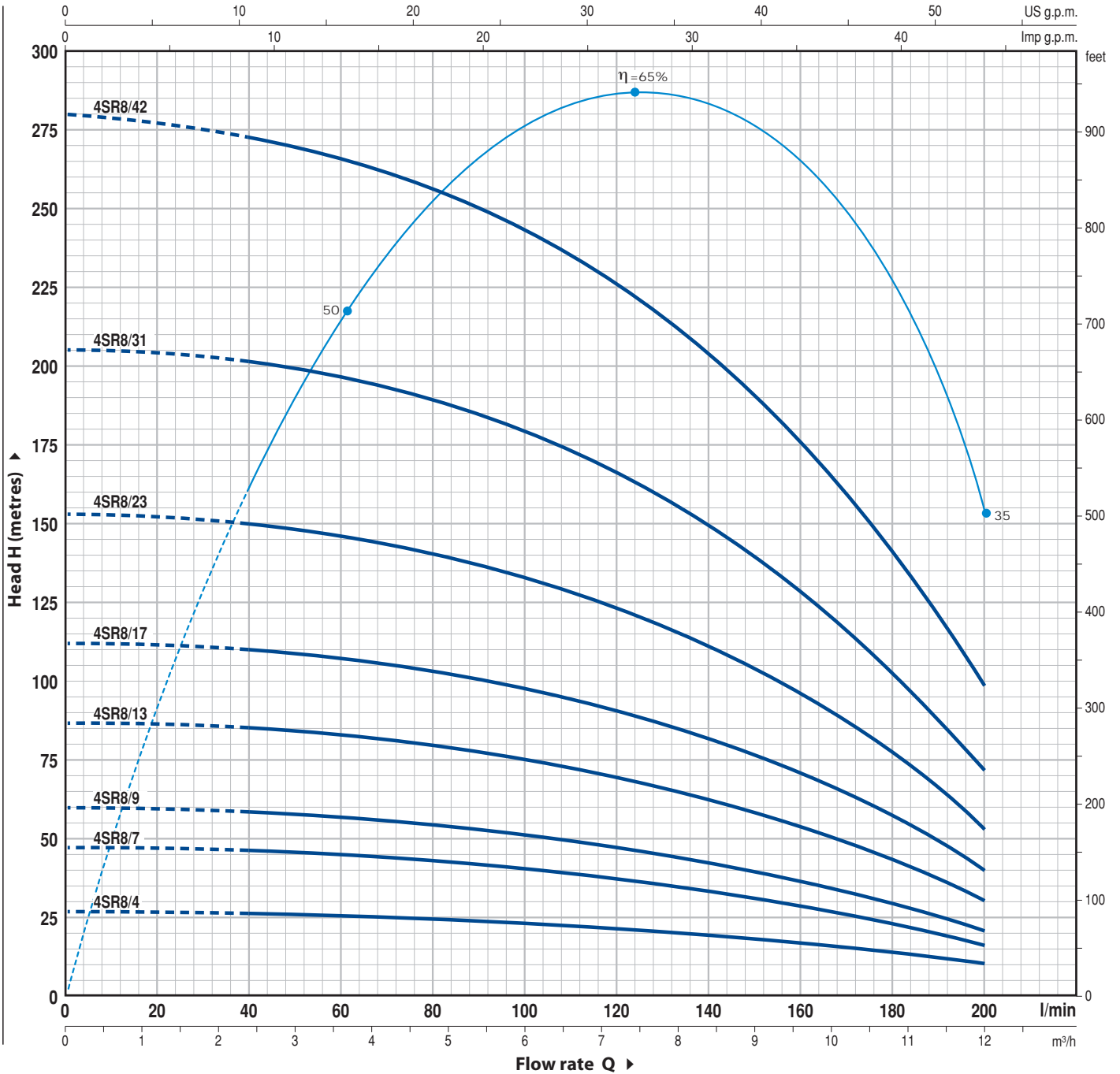

MODEL		POWER		Q	Flow rate (l/min)											
Single-phase	Three-phase	kW	HP		0	2.4	3.6	4.8	6.0	7.2	8.4	9.6	10.8	12.0		
4SR8m/4	4SR8/4	0.75	1	H metres	0	40	60	80	100	120	140	160	180	200		
4SR8m/7	4SR8/7	1.1	1.5		27	26	25	24	23	22	20	17	13	10		
4SR8m/9	4SR8/9	1.5	2		47	46	45	43	41	38	34	29	23	16		
4SR8m/13	4SR8/13	2.2	3		60	58	57	55	52	48	43	37	30	21		
-	4SR8/17	3	4		87	85	83	80	76	70	63	54	43	30		
-	4SR8/23	4	5.5		112	110	108	104	99	92	82	70	56	40		
-	4SR8/31	5.5	7.5		153	150	146	141	134	124	111	95	76	53		
-	4SR8/42	7.5	10		205	200	196	190	181	167	149	128	103	72		
					280	272	266	257	244	225	202	175	140	98		

Q = Flow rate H = Total manometric head

Tolerance of characteristic curves in compliance with EN ISO 9906 App. A.

4SR10

CHARACTERISTIC CURVES AND PERFORMANCE DATA

50 Hz n= 2900 1/min

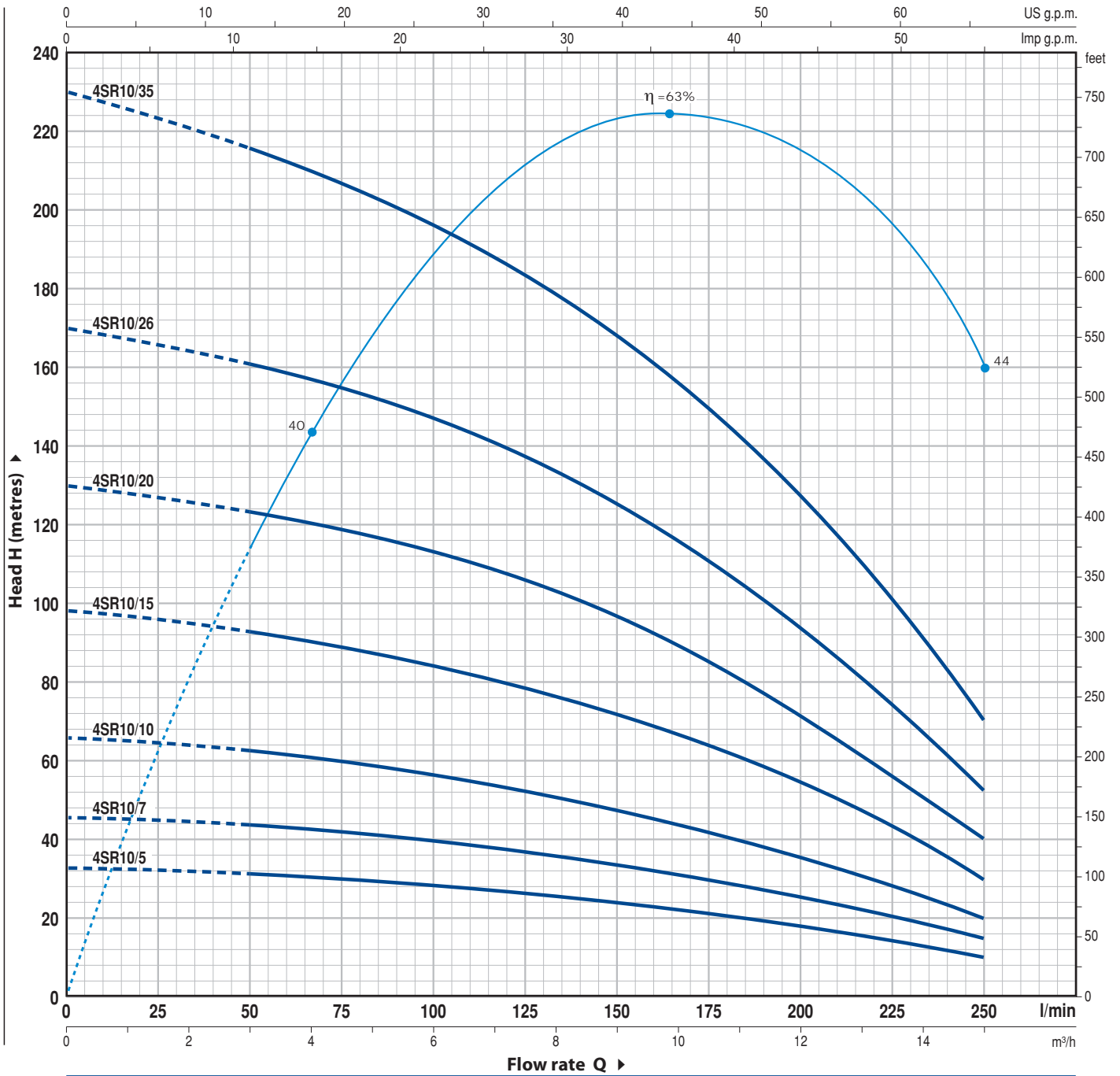

MODEL		POWER		Q	H metres														
Single-phase	Three-phase	kW	HP		m ³ /h	0	3.0	4.5	6.0	7.5	9.0	10.5	12	13.5	15.0				
				l/min	0	50	75	100	125	150	175	200	225	250					
4SR10m/5	4SR10/5	1.1	1.5		33	31	30	28	26	24	21	18	14	10					
4SR10m/7	4SR10/7	1.5	2		46	43	41	39	37	34	30	25	20	15					
4SR10m/10	4SR10/10	2.2	3		66	62	59	56	53	48	42	36	28	20					
-	4SR10/15	3	4		98	92	88	84	79	72	64	53	42	30					
-	4SR10/20	4	5.5		130	123	118	112	106	96	85	71	56	40					
-	4SR10/26	5.5	7.5		170	160	154	147	138	126	110	94	72	52					
-	4SR10/35	7.5	10		230	216	208	197	184	168	148	126	100	70					

Q = Flow rate H = Total manometric head

Tolerance of characteristic curves in compliance with EN ISO 9906 App. A.

CHARACTERISTIC CURVES AND PERFORMANCE DATA

50 Hz n = 2900 1/min

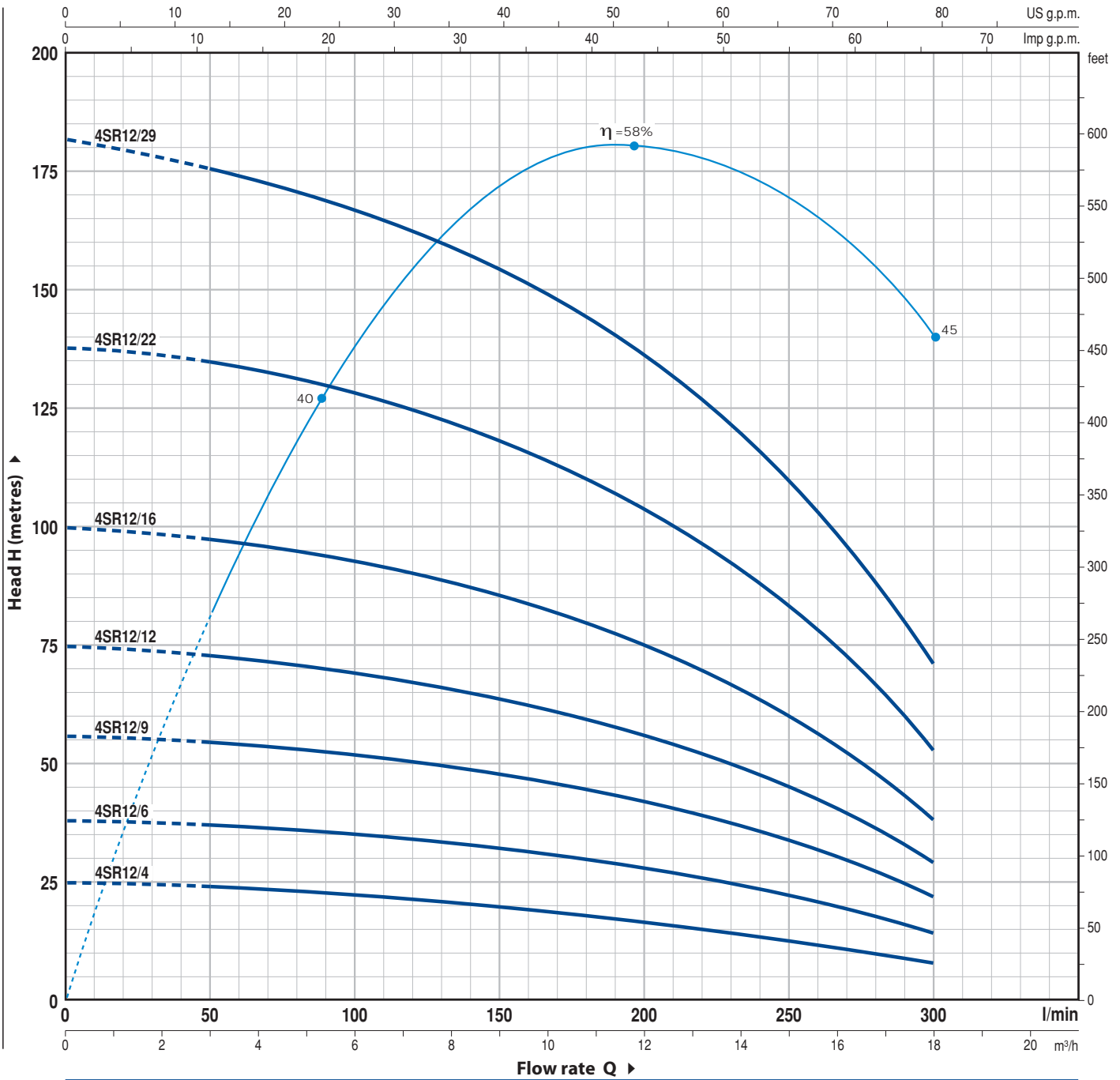

MODEL		POWER		Q	Flow rate (l/min)													
Single-phase	Three-phase	kW	HP		0	3.0	6.0	9.0	12.0	13.2	14.4	15.6	16.8	18.0				
4SR12m/4	4SR12/4	1.1	1.5	H metres	0	50	100	150	200	220	240	260	280	300				
4SR12m/6	4SR12/6	1.5	2		25	24	22	19	16	15	14	12	11	8				
4SR12m/9	4SR12/9	2.2	3		38	37	35	32	28	26	24	21	18	14				
-	4SR12/12	3	4		56	55	52	48	42	39	36	32	27	22				
-	4SR12/16	4	5.5		75	73	69	64	56	52	48	43	36	29				
-	4SR12/22	5.5	7.5		100	97	93	86	75	70	64	57	48	38				
-	4SR12/29	7.5	10		138	135	127	118	103	96	88	78	66	53				
					182	176	167	155	135	126	116	103	88	71				

Q = Flow rate H = Total manometric head

Tolerance of characteristic curves in compliance with EN ISO 9906 App. A.

4SR15

CHARACTERISTIC CURVES AND PERFORMANCE DATA

50 Hz n= 2900 1/min

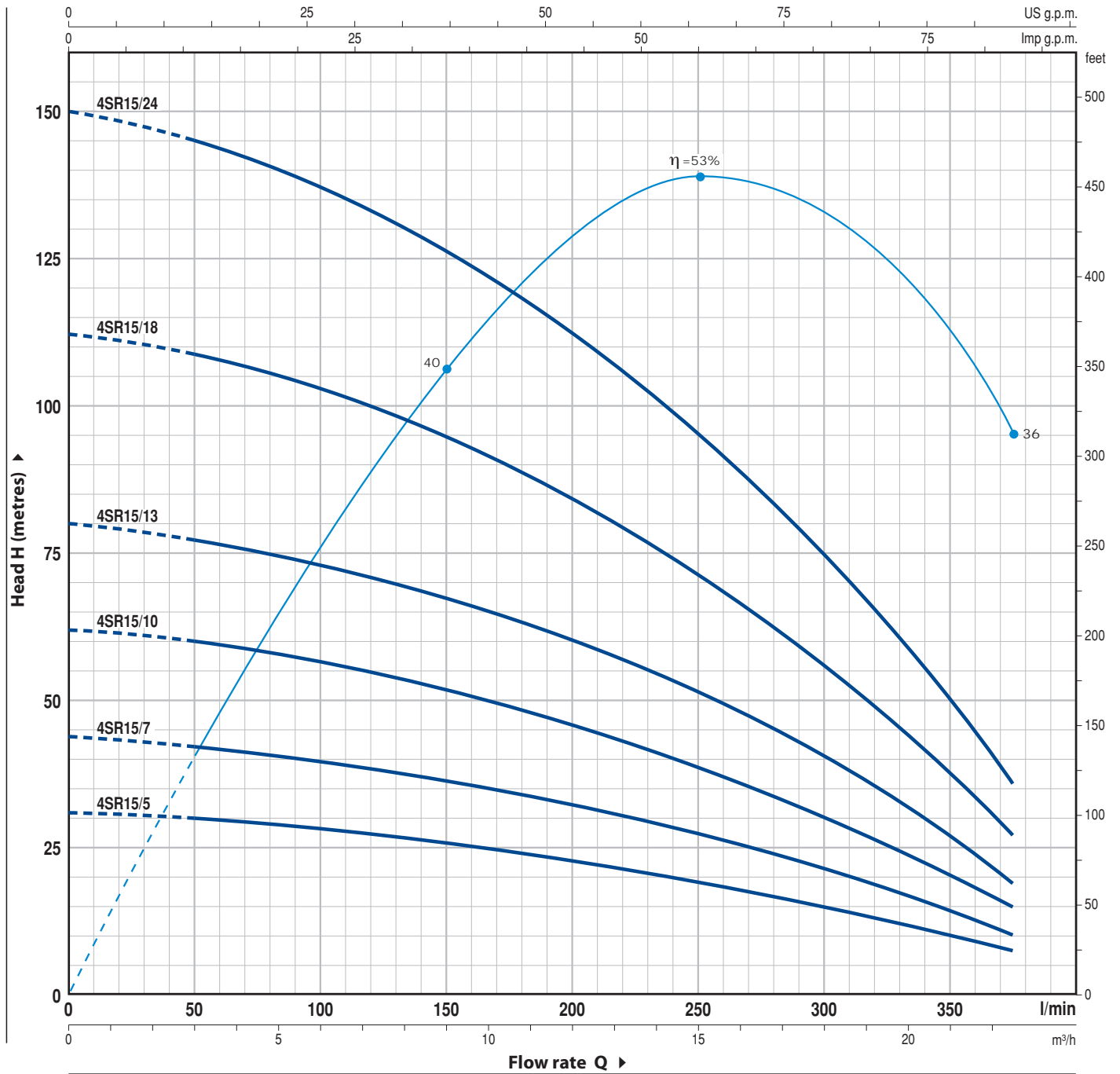

MODEL		POWER		Q	Flow rate (l/min)									
Single-phase	Three-phase	kW	HP		0	3.0	6.0	9.0	12.0	15.0	18.0	21.0	22.5	
					0	50	100	150	200	250	300	350	375	
4SR15m/5	4SR15/5	1.5	2	H metres	31	30	28	26	23	20	15	10	7.5	
4SR15m/7	4SR15/7	2.2	3		44	42	40	37	32	27	20	13	10	
-	4SR15/10	3	4		62	60	57	52	46	38	30	20	15	
-	4SR15/13	4	5.5		80	77	72	68	60	50	40	25	19	
-	4SR15/18	5.5	7.5		112	108	102	95	85	71	55	37	27	
-	4SR15/24	7.5	10		150	145	138	126	112	95	75	50	36	

Q = Flow rate H = Total manometric head

Tolerance of characteristic curves in compliance with EN ISO 9906 App. A.

POS.	DESCRIPTION	CONSTRUCTION CHARACTERISTICS
1	DELIVERY BODY	Precision cast stainless steel AISI 304, complete with threaded delivery port in compliance with ISO 228/1
2	NON-RETURN VALVE	Stainless steel AISI 304
3	MOTOR BRACKET	Stainless steel AISI 304, in compliance with NEMA standards
4	IMPELLER	Lexan 141-R
5	DIFFUSER	Noryl GFN2V
6	STAGE CASING	Stainless steel AISI 304
7	PUMP SHAFT	Stainless steel AISI 304
8	PUMP BEARINGS	Special-technopolymer housing with stainless steel AISI 316, chrome oxide coated, sand resistant shaft bushing
9	DRIVE COUPLING	Stainless steel AISI 316L up to 2.2 kW; stainless steel AISI 304 for higher powers
10	FILTER	Stainless steel AISI 304
11	CABLE COVER	Stainless steel AISI 304
12	MOTOR 4"	4PD = "PEDROLLO" 4FK = "FRANKLIN"

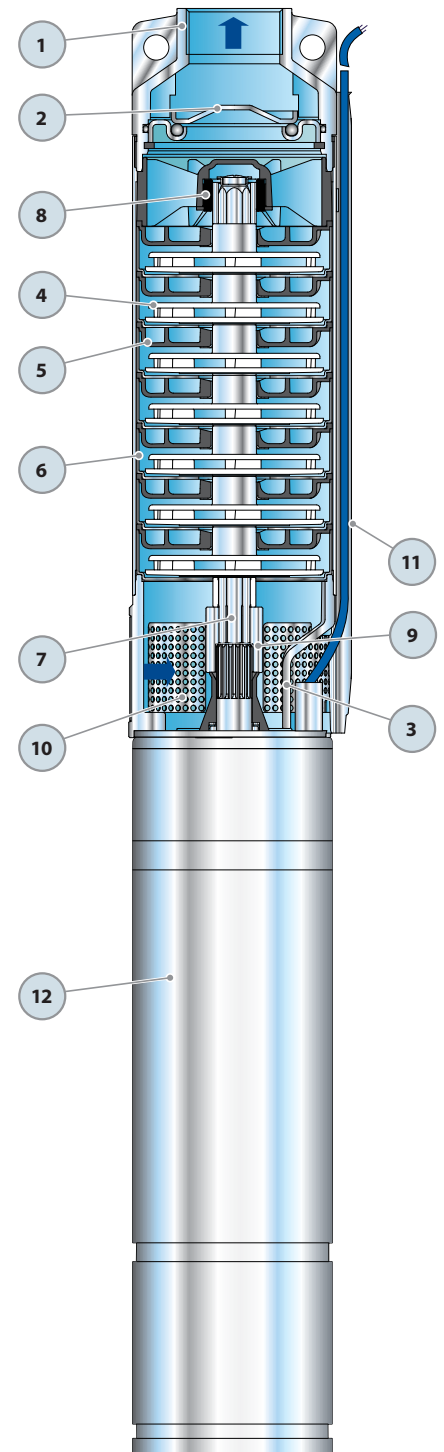

DIMENSIONS AND WEIGHT

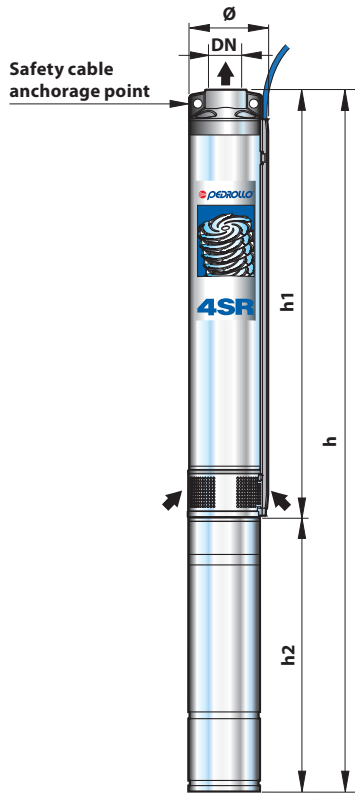

MODEL	PORT DN	DIMENSIONS mm			kg	
		Ø	h1	h2		h
Single-phase						
4SR1m/13 - PD	1 1/4"	98	400	304	704	11.8
4SR1m/18 - PD			517	329	846	14.5
4SR1m/25 - PD			646	354	1000	17.0
4SR1m/35 - PD			856	434	1290	21.6
4SR1m/45 - PD			1065	467	1532	25.5
4SR1.5m/8 - PD			308	304	612	10.9
4SR1.5m/13 - PD			400	329	729	14.5
4SR1.5m/17 - PD			499	354	853	15.5
4SR1.5m/25 - PD			646	434	1080	20.0
4SR1.5m/32 - PD			800	467	1267	24.3
4SR1.5m/46 - PD			1134	565	1699	31.9
4SR2m/7 - PD			290	304	594	10.7
4SR2m/10 - PD			345	329	674	12.5
4SR2m/13 - PD			400	354	754	14.4
4SR2m/20 - PD			554	434	988	18.3
4SR2m/27 - PD			683	467	1150	21.4
4SR2m/39 - PD			929	565	1494	29.2
4SR4m/7 - PD			314	329	643	12.1
4SR4m/9 - PD			358	354	712	13.7
4SR4m/14 - PD			468	434	902	17.2
4SR4m/18 - PD	580	467	1047	19.9		
4SR4m/26 - PD	756	565	1321	25.5		
4SR6m/4 - PD	281	329	610	12.8		
4SR6m/6 - PD	341	354	695	13.4		
4SR6m/9 - PD	431	434	865	16.6		
4SR6m/13 - PD	576	467	1043	19.5		
4SR6m/17 - PD	695	565	1260	25.5		
4SR8m/4 - PD	281	354	635	12.8		
4SR8m/7 - PD	371	434	805	16.1		
4SR8m/9 - PD	431	467	898	18.2		
4SR8m/13 - PD	576	565	1141	24.1		
4SR10m/5 - PD	416	434	850	17.0		
4SR10m/7 - PD	518	467	985	18.8		
4SR10m/10 - PD	709	565	1274	25.0		
4SR12m/4 - PD	365	434	799	16.5		
4SR12m/6 - PD	467	467	934	17.7		
4SR12m/9 - PD	658	565	1223	25.0		
4SR15m/5 - PD	421	467	888	18.6		
4SR15m/7 - PD	525	565	1090	24.0		

MODEL	PORT DN	DIMENSIONS mm			kg	
		Ø	h1	h2		h
Three-phase						
4SR1/13 - PD	1 1/4"	98	400	304	704	13.7
4SR1/18 - PD			517	304	821	14.4
4SR1/25 - PD			646	329	975	17.1
4SR1/35 - PD			856	354	1210	19.9
4SR1/45 - PD			1065	428	1493	23.0
4SR1.5/8 - PD			308	304	612	10.8
4SR1.5/13 - PD			400	304	704	11.7
4SR1.5/17 - PD			499	329	828	14.3
4SR1.5/25 - PD			646	354	1000	17.8
4SR1.5/32 - PD			800	428	1228	24.3
4SR1.5/46 - PD			1134	467	1601	27.7
4SR2/7 - PD			290	304	594	10.5
4SR2/10 - PD			345	304	649	11.3
4SR2/13 - PD			400	329	729	13.3
4SR2/20 - PD			554	354	908	16.7
4SR2/27 - PD			683	428	1111	19.9
4SR2/39 - PD			929	467	1396	25.0
4SR4/7 - PD			314	304	618	12.2
4SR4/9 - PD			358	329	687	12.5
4SR4/14 - PD			468	354	822	15.8
4SR4/18 - PD			580	428	1008	17.6
4SR4/26 - PD			756	467	1223	21.4
4SR4/35 - PD			978	522	1500	26.1
4SR4/46 - PD			1295	587	1882	34.3
4SR4/60 - PD			1652	687	2339	45.1
4SR6/4 - PD			281	304	585	10.8
4SR6/6 - PD			341	329	670	13.1
4SR6/9 - PD			431	354	785	14.9
4SR6/13 - PD			576	428	1004	17.2
4SR6/17 - PD			695	467	1162	20.3
4SR6/23 - PD	900	522	1422	24.6		
4SR6/31 - PD	1164	587	1751	32.0		
4SR6/42 - PD	1519	687	2206	40.7		
4SR6/56 - PD	2063	768	2831	51.7		
4SR8/4 - PD	281	329	610	12.6		
4SR8/7 - PD	371	354	725	13.7		
4SR8/9 - PD	431	428	859	16.0		
4SR8/13 - PD	576	467	1043	19.2		
4SR8/17 - PD	695	522	1217	24.0		
4SR8/23 - PD	900	587	1487	27.6		
4SR8/31 - PD	1164	687	1851	36.6		
4SR8/42 - PD	1519	768	2287	44.6		
4SR10/5 - PD	416	354	770	15.3		
4SR10/7 - PD	518	428	946	16.9		
4SR10/10 - PD	709	467	1176	21.4		
4SR10/15 - PD	1001	522	1523	25.6		
4SR10/20 - PD	1256	587	1843	33.4		
4SR10/26 - PD	1599	687	2286	41.4		
4SR10/35 - PD	2095	768	2863	49.4		
4SR12/4 - PD	365	354	719	13.5		
4SR12/6 - PD	467	428	895	17.7		
4SR12/9 - PD	658	467	1125	21.1		
4SR12/12 - PD	810	522	1332	24.4		
4SR12/16 - PD	1052	587	1639	28.9		
4SR12/22 - PD	1358	687	2045	37.5		
4SR12/29 - PD	1752	768	2520	46.5		
4SR15/5 - PD	421	428	849	16.1		
4SR15/7 - PD	525	467	992	18.8		
4SR15/10 - PD	719	522	1241	24.5		
4SR15/13 - PD	874	587	1461	27.3		
4SR15/18 - PD	1172	687	1859	36.3		
4SR15/24 - PD	1521	768	2289	43.7		

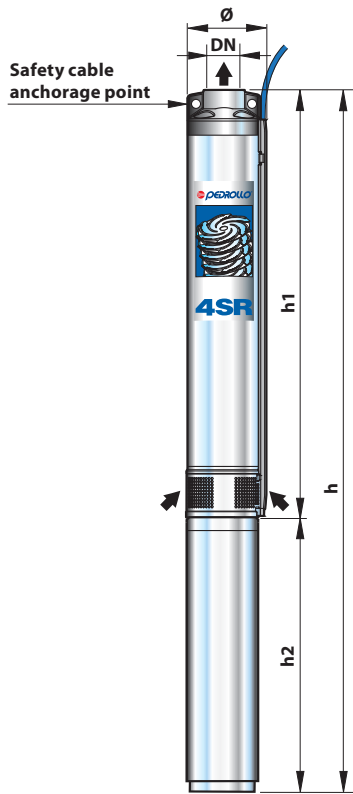

MODEL	PORT DN	DIMENSIONS mm			kg	
		Ø	h1	h2		h
Single-phase						
4SR1m/13 - FK	1 1/4"	98	400	242	642	13.0
4SR1m/18 - FK			517	271	788	15.4
4SR1m/25 - FK			646	298	944	18.6
4SR1m/35 - FK			856	327	1183	21.8
4SR1m/45 - FK			1065	356	1421	25.4
4SR1.5m/8 - FK			308	242	550	12.6
4SR1.5m/13 - FK			400	271	671	14.9
4SR1.5m/17 - FK			499	298	797	16.9
4SR1.5m/25 - FK			646	327	973	19.9
4SR1.5m/32 - FK			800	356	1156	22.8
4SR1.5m/46 - FK			1134	460	1594	31.7
4SR2m/7 - FK			290	242	532	11.6
4SR2m/10 - FK			345	271	616	13.5
4SR2m/13 - FK			400	298	698	15.3
4SR2m/20 - FK			554	327	881	18.0
4SR2m/27 - FK			683	356	1039	21.1
4SR2m/39 - FK			929	460	1389	28.1
4SR4m/7 - FK			2"	98	314	271
4SR4m/9 - FK	358	298			656	14.7
4SR4m/14 - FK	468	327			795	17.1
4SR4m/18 - FK	580	356			936	20.5
4SR4m/26 - FK	756	460			1216	25.7
4SR6m/4 - FK	281	271			552	13.8
4SR6m/6 - FK	341	298			639	14.6
4SR6m/9 - FK	431	327			758	16.6
4SR6m/13 - FK	576	356			932	19.4
4SR6m/17 - FK	695	460			1155	25.8
4SR8m/4 - FK	281	298			579	14.1
4SR8m/7 - FK	371	327			698	16.1
4SR8m/9 - FK	431	356			787	16.6
4SR8m/13 - FK	576	460			1036	24.5
4SR10m/5 - FK	416	327			743	17.0
4SR10m/7 - FK	518	356			874	19.3
4SR10m/10 - FK	709	460			1169	25.4
4SR12m/4 - FK	365	327			692	16.6
4SR12m/6 - FK	467	356	823	18.8		
4SR12m/9 - FK	658	460	1118	25.2		
4SR15m/5 - FK	421	356	777	18.5		
4SR15m/7 - FK	525	460	985	23.8		

MODEL	PORT DN	DIMENSIONS mm			kg			
		Ø	h1	h2		h		
Three-phase								
4SR1/13 - FK	1 1/4"	98	400	223	623	13.2		
4SR1/18 - FK			517	242	759	14.7		
4SR1/25 - FK			646	271	917	17.2		
4SR1/35 - FK			856	298	1154	20.7		
4SR1/45 - FK			1065	327	1392	24.0		
4SR1.5/8 - FK			308	223	531	11.6		
4SR1.5/13 - FK			400	242	642	13.6		
4SR1.5/17 - FK			499	271	770	16.9		
4SR1.5/25 - FK			646	298	944	18.3		
4SR1.5/32 - FK			800	327	1127	21.8		
4SR1.5/46 - FK			1134	356	1490	27.2		
4SR2/7 - FK			290	223	513	10.8		
4SR2/10 - FK			345	242	587	11.8		
4SR2/13 - FK			400	271	671	13.5		
4SR2/20 - FK			554	298	852	16.3		
4SR2/27 - FK			683	327	1010	20.4		
4SR2/39 - FK			929	356	1285	24.1		
4SR4/7 - FK			314	242	556	11.4		
4SR4/9 - FK			358	271	629	13.5		
4SR4/14 - FK			468	298	766	15.4		
4SR4/18 - FK			580	327	907	17.3		
4SR4/26 - FK			756	356	1112	20.4		
4SR4/35 - FK			978	423	1401	26.5		
4SR4/46 - FK			1295	583	1878	39.6		
4SR4/60 - FK			1652	698	2350	49.3		
4SR6/4 - FK			2"	98	281	242	523	12.5
4SR6/6 - FK					341	271	612	12.8
4SR6/9 - FK					431	298	729	14.9
4SR6/13 - FK					576	327	903	18.2
4SR6/17 - FK					695	356	1051	20.2
4SR6/23 - FK	900	423			1323	24.5		
4SR6/31 - FK	1164	583			1747	36.4		
4SR6/42 - FK	1519	698			2217	44.9		
4SR6/56 - FK	2063	774			2837	55.5		
4SR8/4 - FK	281	271			552	12.3		
4SR8/7 - FK	371	298			669	14.4		
4SR8/9 - FK	431	327			758	15.9		
4SR8/13 - FK	576	356			932	18.5		
4SR8/17 - FK	695	423			1118	22.8		
4SR8/23 - FK	900	583			1483	33.9		
4SR8/31 - FK	1164	698			1862	41.7		
4SR8/42 - FK	1519	774			2293	48.4		
4SR10/5 - FK	416	298			714	15.7		
4SR10/7 - FK	518	327	845	17.9				
4SR10/10 - FK	709	356	1065	20.4				
4SR10/15 - FK	1001	423	1424	26.1				
4SR10/20 - FK	1256	583	1839	36.6				
4SR10/26 - FK	1599	698	2297	45.0				
4SR10/35 - FK	2095	774	2869	53.2				
4SR12/4 - FK	365	298	663	15.3				
4SR12/6 - FK	467	327	794	17.4				
4SR12/9 - FK	658	356	1014	20.6				
4SR12/12 - FK	810	423	1233	26.2				
4SR12/16 - FK	1052	583	1635	34.2				
4SR12/22 - FK	1358	698	2056	42.7				
4SR12/29 - FK	1752	774	2526	48.4				
4SR15/5 - FK	421	327	748	17.1				
4SR15/7 - FK	525	356	881	19.3				
4SR15/10 - FK	719	423	1142	23.5				
4SR15/13 - FK	874	583	1457	33.0				
4SR15/18 - FK	1172	698	1870	41.0				
4SR15/24 - FK	1521	774	2295	47.5				

DIMENSIONS AND WEIGHT (PUMP ONLY)

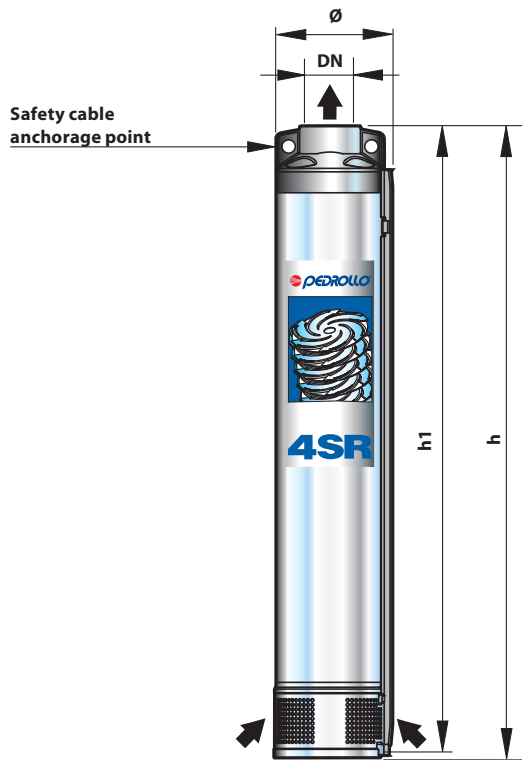

MODEL	PORT	DIMENSIONS mm			kg
		Ø	h1	h	
Pump	DN				
4SR1/13 - HYD	1 1/4"	98	400	403	4.7
4SR1/18 - HYD			517	520	5.9
4SR1/25 - HYD			646	649	7.4
4SR1/35 - HYD			856	859	9.4
4SR1/45 - HYD			1065	1068	11.4
4SR1.5/8 - HYD			308	311	3.8
4SR1.5/13 - HYD			400	403	4.8
4SR1.5/17 - HYD			499	502	5.7
4SR1.5/25 - HYD			646	649	7.3
4SR1.5/32 - HYD			800	803	9.2
4SR1.5/46 - HYD			1134	1137	13.2
4SR2/7 - HYD			290	293	3.6
4SR2/10 - HYD			345	348	4.2
4SR2/13 - HYD			400	403	4.8
4SR2/20 - HYD			554	557	7.0
4SR2/27 - HYD			683	686	7.7
4SR2/39 - HYD			929	932	10.5
4SR4/7 - HYD			314	317	3.8
4SR4/9 - HYD			358	361	4.3
4SR4/14 - HYD			468	471	5.4
4SR4/18 - HYD	580	583	6.6		
4SR4/26 - HYD	756	759	8.3		
4SR4/35 - HYD	978	981	10.7		
4SR4/46 - HYD	1295	1298	15.0		
4SR4/60 - HYD	1652	1655	19.4		
4SR6/4 - HYD	2"	98	281	284	3.7
4SR6/6 - HYD			341	344	4.0
4SR6/9 - HYD			431	434	4.8
4SR6/13 - HYD			576	579	6.1
4SR6/17 - HYD			695	698	7.1
4SR6/23 - HYD			900	903	9.3
4SR6/31 - HYD			1164	1167	11.8
4SR6/42 - HYD			1519	1522	15.0
4SR6/56 - HYD			2063	2066	22.0
4SR8/4 - HYD			281	284	3.5
4SR8/7 - HYD			371	374	4.2
4SR8/9 - HYD			431	434	4.7
4SR8/13 - HYD	576	579	6.1		
4SR8/17 - HYD	695	698	7.2		
4SR8/23 - HYD	900	903	9.3		
4SR8/31 - HYD	1164	1167	11.8		
4SR8/42 - HYD	1519	1522	14.9		
4SR10/5 - HYD	416	419	4.4		
4SR10/7 - HYD	518	521	5.3		
4SR10/10 - HYD	709	712	6.9		
4SR10/15 - HYD	1001	1004	9.5		
4SR10/20 - HYD	1256	1259	12.0		
4SR10/26 - HYD	1599	1602	15.7		
4SR10/35 - HYD	2095	2098	19.7		
4SR12/4 - HYD	365	368	4.0		
4SR12/6 - HYD	467	470	4.8		
4SR12/9 - HYD	658	661	6.6		
4SR12/12 - HYD	810	813	8.1		
4SR12/16 - HYD	1052	1055	9.6		
4SR12/22 - HYD	1358	1361	12.8		
4SR12/29 - HYD	1752	1755	15.9		
4SR15/5 - HYD	421	424	4.5		
4SR15/7 - HYD	525	528	5.3		
4SR15/10 - HYD	719	722	7.0		
4SR15/13 - HYD	874	877	8.4		
4SR15/18 - HYD	1172	1175	11.1		
4SR15/24 - HYD	1521	1524	14.0		

INSTALLATION EXAMPLE

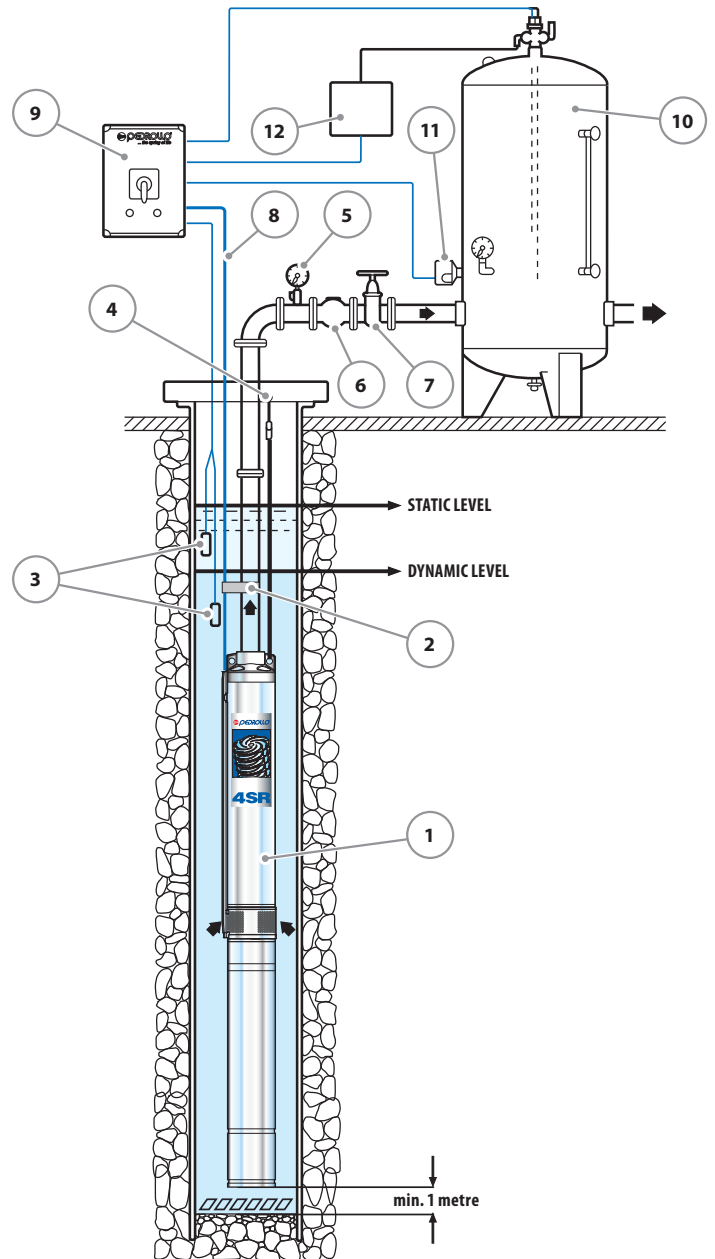
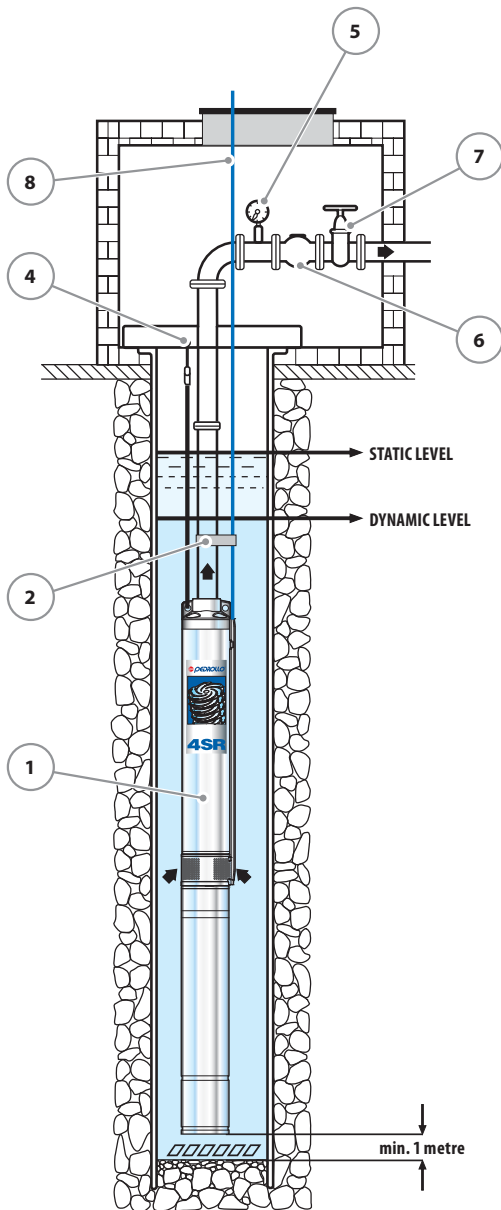

COMPONENTS

- | | |
|--|--|
| <ul style="list-style-type: none"> 1) Submersible pump 2) Power cable clamps 3) Level probes; prevent dry running 4) Pump anchorage 5) Pressure gauge 6) Non-return valve 7) Gate valve; for flow rate regulation | <ul style="list-style-type: none"> 8) Power cable 9) Control box 10) Pressure vessel 11) Pressure switch 12) Electro valve/electro-compressor |
|--|--|

➔ The 4SR series pumps should be installed in boreholes of at least 4" (100 mm) in diameter. The pump should be lowered into the borehole, by means of the delivery pipe, to such a depth (min. 50 cm and at least one metre from the bottom) that it is completely immersed during operation when the level of water in the borehole may reduce. It is good practice to secure the pump by attaching a stainless steel cable to the anchorage points present on the delivery body.



PERFORMANCE RANGE

- Flow rate up to **1000 l/min** (60 m³/h)
- Head up to **390 m**

APPLICATION LIMITS

- Maximum liquid temperature **+35 °C**
- Maximum sand content **100 g/m³**
- **100 m** immersion limit
- Installation:
 - vertical
 - horizontal, with the following limits: up to **12 stages** or **11 kW**
- Starts/hour: 20 at regular intervals
- Minimum flow rate for motor cooling **16 cm/s** (0.5 m/s for 30 kW)
- Continuous service **S1**

CONSTRUCTION AND SAFETY STANDARDS

ELECTRIC MOTOR

– Three-phase 400 V - 50 Hz

4 m long power cable

EN 60034-1
IEC 60034-1
CEI 2-3



CERTIFICATIONS



INSTALLATION AND USE

Suitable for use with clean water with a sand content of no more than 100 g/m³. As a result of their high efficiency and reliability, they are suitable for use in civil, agricultural and industrial applications such as for the distribution of water in combination with pressure sets, for irrigation and for pressure boosting in fire-fighting sets, etc.

OPTIONALS AVAILABLE ON REQUEST

- 6SR-HYD pumps with double cable cover suitable for dual voltage 400/690 V (star/delta) motors from 11 kW to 30 kW
- Other voltages or 60 Hz frequency

GUARANTEE

1 year subject to terms and conditions

PERFORMANCE RANGE

50 Hz n= 2900 1/min

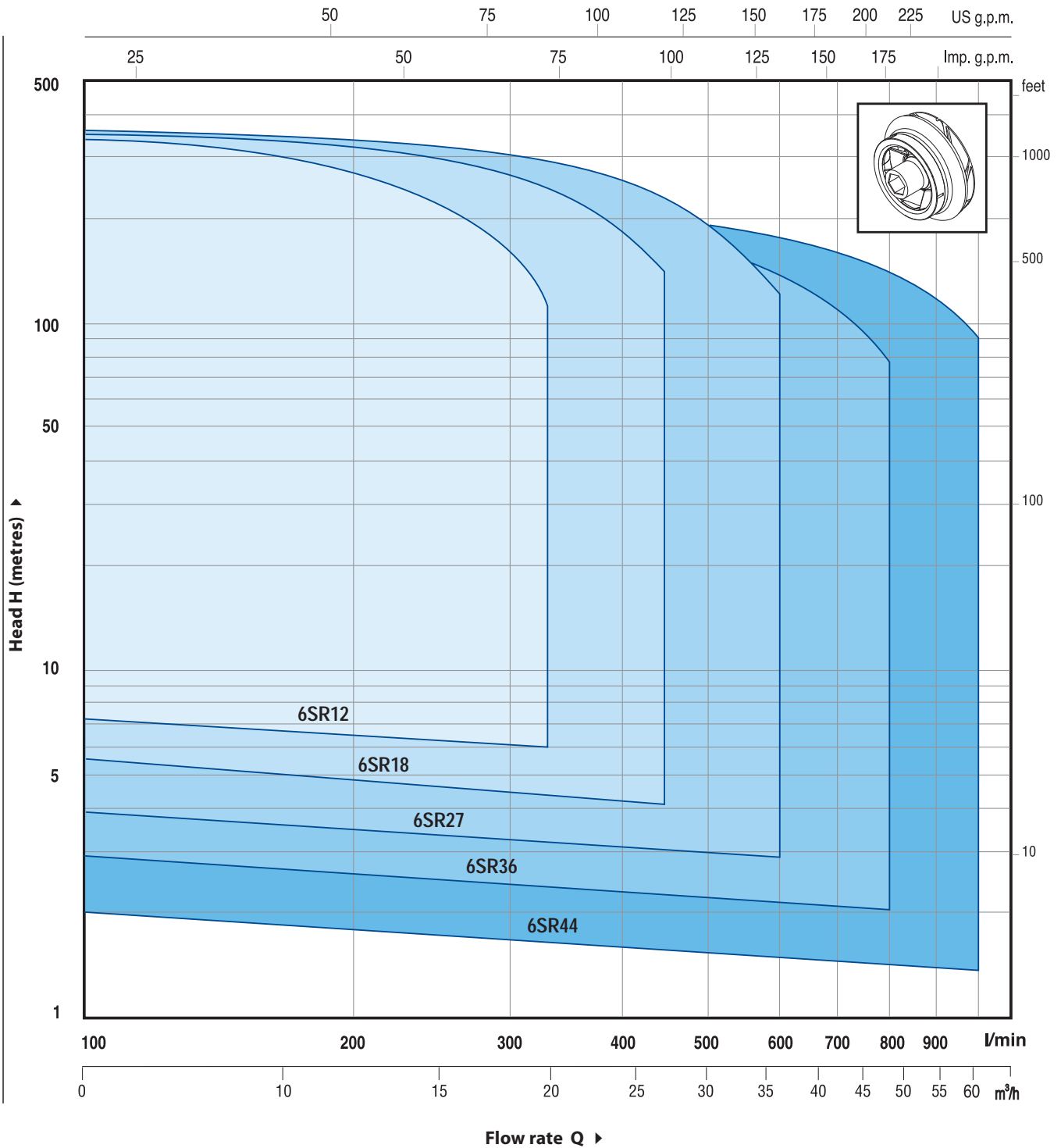

DESCRIPTION

6 SR 12 / 8 - PD or HYD

- Borehole diameter in inches _____
- Series _____
- Flow rate in m³/h at the point of highest efficiency _____
- Number of stages _____
- PD:** pump with "PEDROLLO" motor _____
- HYD:** pump without motor _____

6SR12

CHARACTERISTIC CURVES AND PERFORMANCE DATA

50 Hz n= 2900 1/min

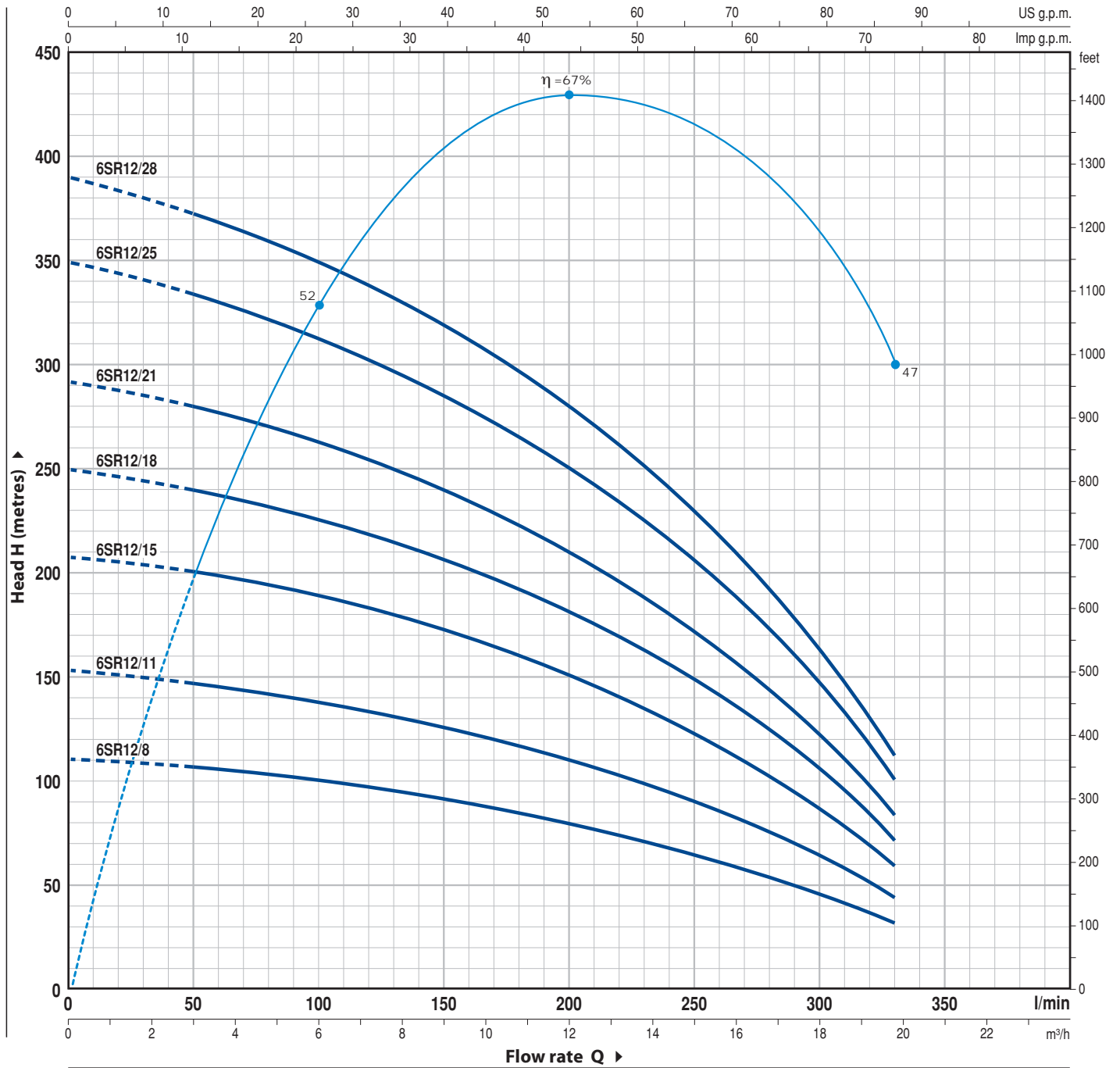

MODEL	POWER		Q	Flow rate (l/min)										
	kW	HP		0	3.0	6.0	9.0	12.0	15.0	18.0	19.8			
Three-phase				0	50	100	150	200	250	300	330			
6SR12/8	4	5.5	H metres	111	106	100	91	80	66	47	32			
6SR12/11	5.5	7.5		153	146	138	125	110	91	65	44			
6SR12/15	7.5	10		208	199	189	171	150	124	88	60			
6SR12/18	9.2	12.5		250	239	225	205	180	149	106	72			
6SR12/21	11	15		292	279	263	239	210	174	124	84			
6SR12/25	13	17.5		349	331	313	285	250	206	147	100			
6SR12/28	15	20		390	371	350	319	280	231	165	112			

Q = Flow rate H = Total manometric head

Tolerance of characteristic curves in compliance with EN ISO 9906 App. A.

CHARACTERISTIC CURVES AND PERFORMANCE DATA

50 Hz n= 2900 1/min

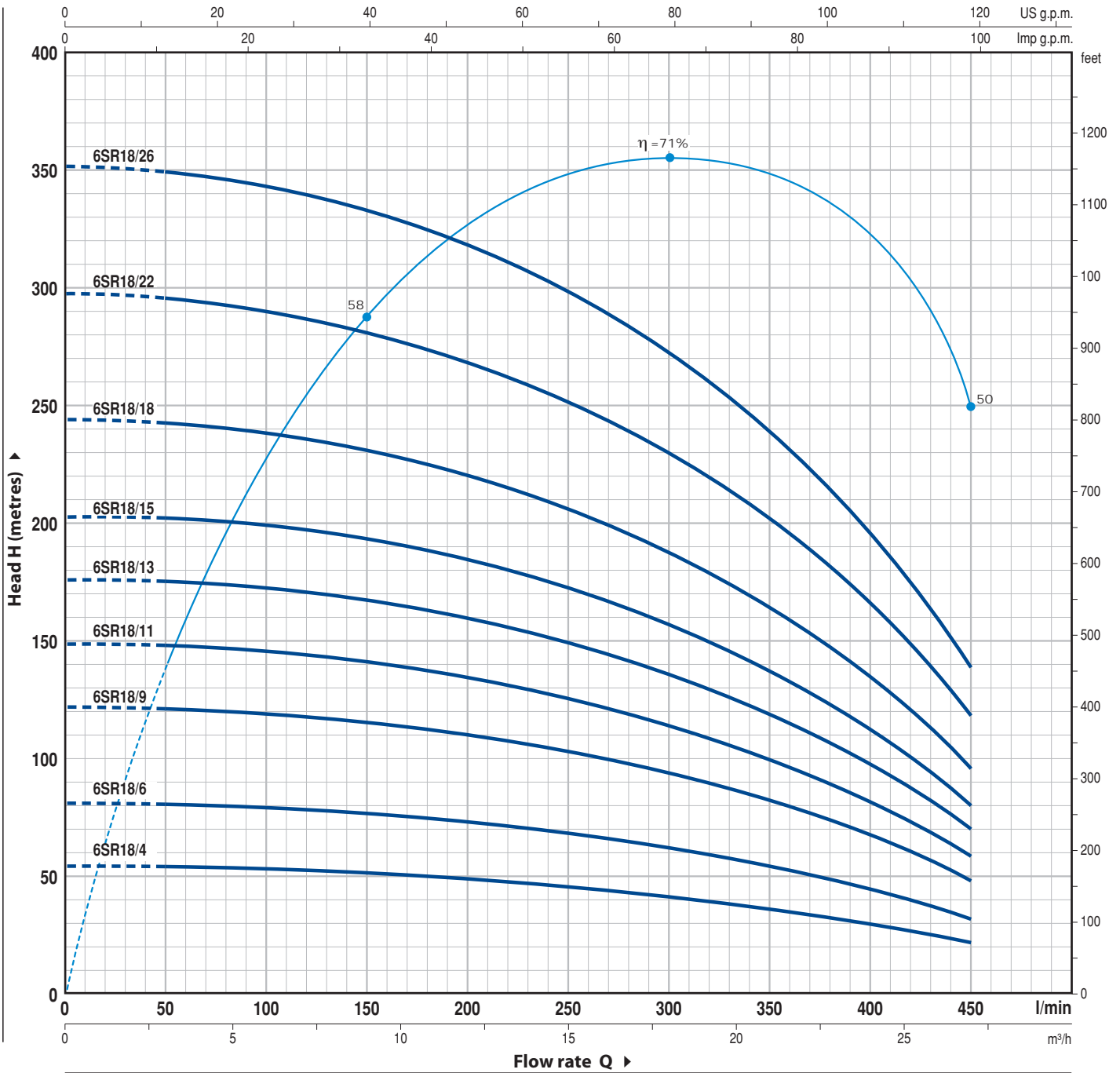

MODEL	POWER		Q	Flow rate												
	kW	HP		0	3	6	9	12	15	18	21	24	27			
Three-phase			l/min	0	50	100	150	200	250	300	350	400	450			
6SR18/4	4	5.5	H metres	54	53.8	53	51	49	46	42	37	30	22			
6SR18/6	5.5	7.5		81	80.5	79	77	74	69	63	55	45	32			
6SR18/9	7.5	10		122	121	119	116	111	103	94	83	68	48			
6SR18/11	9.2	12.5		149	148	145.5	141	135	126	115	101	83	59			
6SR18/13	11	15		176	175	172	167	160	149	136	120	98	70			
6SR18/15	13	17.5		203	202	199	193	185	172	157	138	113	80			
6SR18/18	15	20		244	242	238	231	221	206	188	165	135	96			
6SR18/22	18.5	25		298	296	291	282	270	252	230	202	165	118			
6SR18/26	22	30		352	350	344	334	320	298	272	239	195	139			

Q = Flow rate H = Total manometric head

Tolerance of characteristic curves in compliance with EN ISO 9906 App. A.

6SR27

CHARACTERISTIC CURVES AND PERFORMANCE DATA

50 Hz n= 2900 1/min

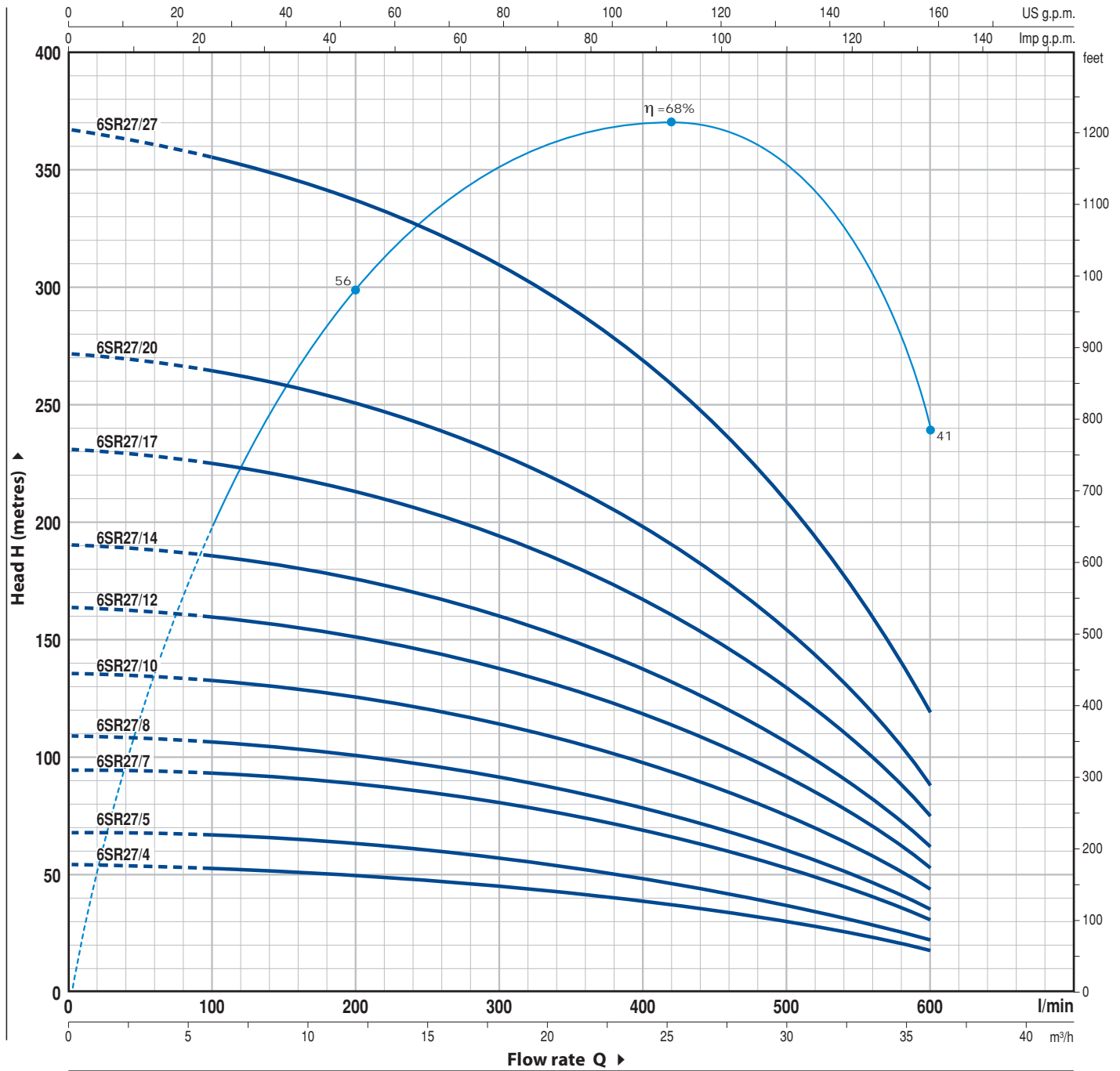

MODEL	POWER		Q	0	6	12	18	24	30	36
	kW	HP		0	100	200	300	400	500	600
Three-phase										
6SR27/4	4	5.5	H metres	54	53	49	45	40	30	18
6SR27/5	5.5	7.5		68	66	62	57	50	37	22
6SR27/7	7.5	10		95	92	87	80	70	52	31
6SR27/8	9.2	12.5		109	106	99	91	80	59	35
6SR27/10	11	15		136	132	124	114	100	74	44
6SR27/12	13	17.5		164	159	149	137	120	89	53
6SR27/14	15	20		191	185	174	160	140	104	62
6SR27/17	18.5	25		231	224	211	194	170	126	75
6SR27/20	22	30		272	264	248	228	200	148	88
6SR27/27	30	40		367	356	335	308	270	205	119

Q = Flow rate H = Total manometric head

Tolerance of characteristic curves in compliance with EN ISO 9906 App. A.

CHARACTERISTIC CURVES AND PERFORMANCE DATA

50 Hz n= 2900 1/min

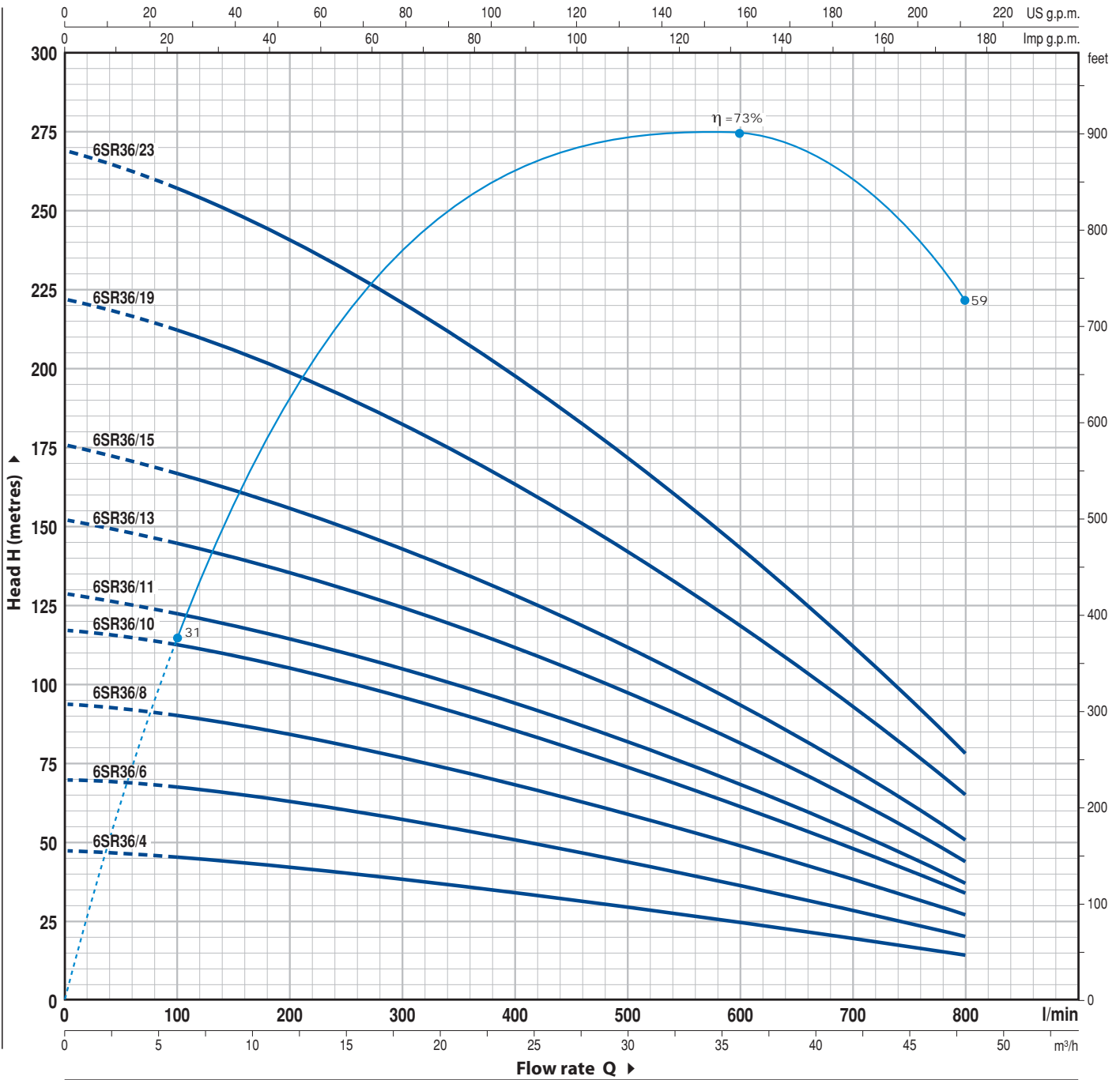

MODEL	POWER		Q	Flow rate											
	kW	HP		0	6	12	18	24	30	36	42	48			
Three-phase			l/min	0	100	200	300	400	500	600	700	800			
6SR36/4	4	5.5	H metres	47	45	42	38	34	29	25	19	14			
6SR36/6	5.5	7.5		70	67	63	57	51	44	37	29	20			
6SR36/8	7.5	10		94	89	84	76	68	59	50	39	27			
6SR36/10	9.2	12.5		117	111	105	95	85	74	62	48	34			
6SR36/11	11	15		129	123	115	105	93	81	68	53	37			
6SR36/13	13	17.5		152	145	136	124	110	96	81	63	44			
6SR36/15	15	20		176	167	157	143	127	110	93	72	51			
6SR36/19	18.5	25		222	212	199	181	161	140	118	92	65			
6SR36/23	22	30		269	256	241	219	195	169	143	111	78			

Q = Flow rate H = Total manometric head

Tolerance of characteristic curves in compliance with EN ISO 9906 App. A.

6SR44

CHARACTERISTIC CURVES AND PERFORMANCE DATA

50 Hz n= 2900 1/min

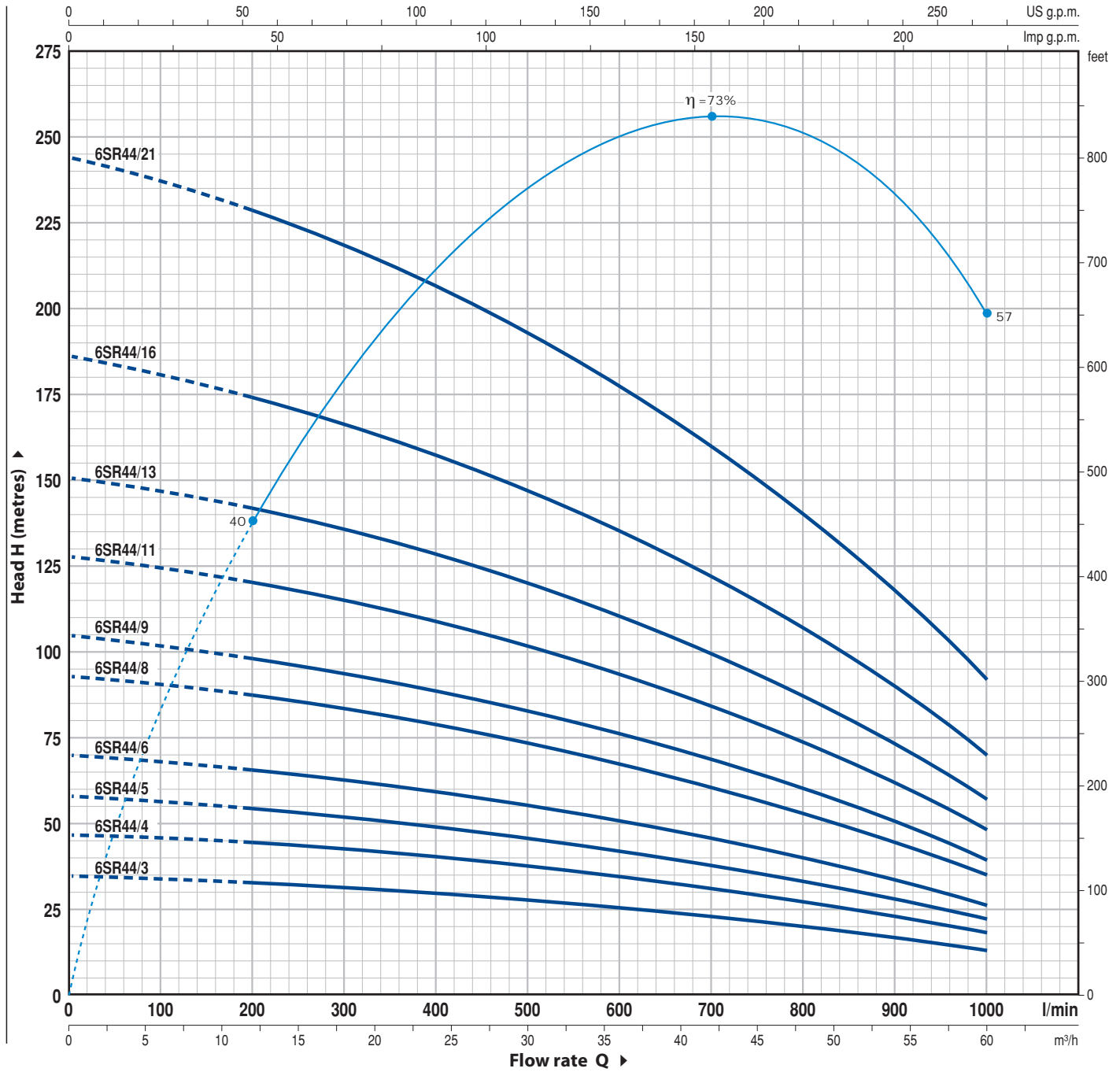

MODEL	POWER		Q	H metres											
	kW	HP		0	12	18	24	30	36	42	48	54	60		
Three-phase			l/min	0	200	300	400	500	600	700	800	900	1000		
6SR44/3	4	5.5		35	33	31	30	28	26	23	20	17	13		
6SR44/4	5.5	7.5		47	44	42	40	37	34	31	27	23	18		
6SR44/5	7.5	10		58	54	52	49	46	43	38	33	28	22		
6SR44/6	9.2	12.5		70	65	62	59	56	51	46	40	34	26		
6SR44/8	11	15		93	87	83	79	74	68	61	53	45	35		
6SR44/9	13	17.5		105	98	93	89	83	77	69	60	51	39		
6SR44/11	15	20		128	120	114	109	102	94	84	73	62	48		
6SR44/13	18.5	25		151	141	135	128	120	111	99	86	73	57		
6SR44/16	22	30		186	174	166	158	148	136	122	106	90	70		
6SR44/21	30	40		244	228	218	207	194	179	160	139	118	92		

Q = Flow rate H = Total manometric head

Tolerance of characteristic curves in compliance with EN ISO 9906 App. A.

INSTALLATION EXAMPLE

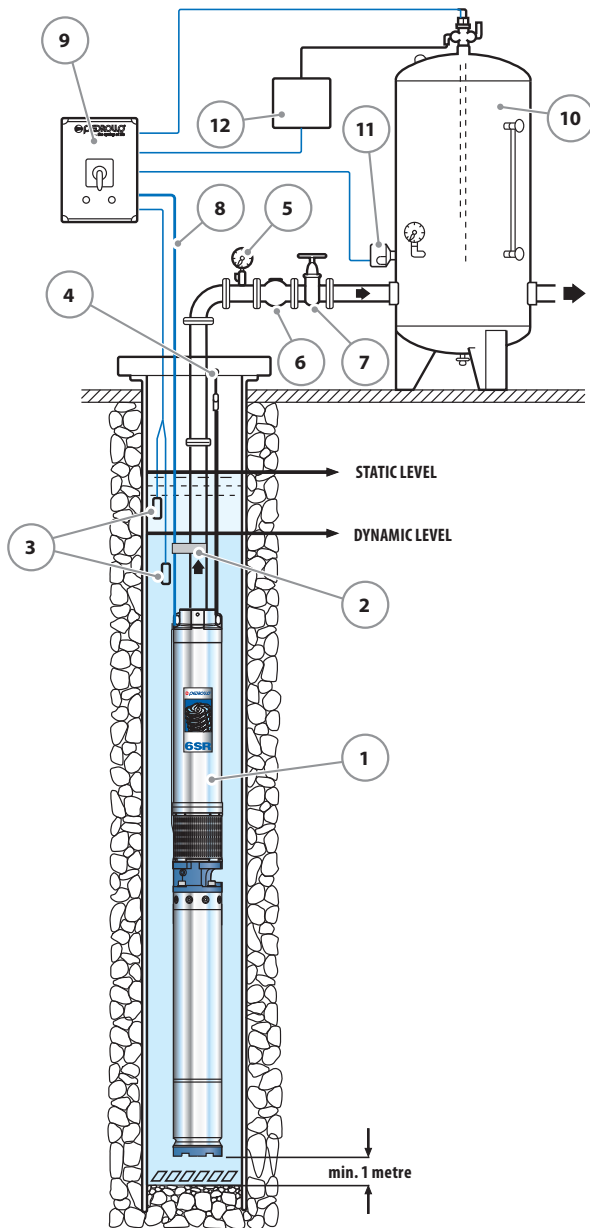

Vertical installation

→ The 6SR series pumps should be installed in boreholes of at least 6" (150 mm) in diameter. The pump should be lowered into the borehole, by means of the delivery pipe, to such a depth (min. 50 cm and at least one metre from the bottom) that it is completely immersed during operation when the level of water in the borehole may reduce. It is good practice to secure the pump by attaching a stainless steel cable to the anchorage points present on the delivery body.

COMPONENTS

- 1) Submersible pump
- 2) Power cable clamps
- 3) Level probes
- 4) Pump anchorage
- 5) Pressure gauge
- 6) Non-return valve
- 7) Gate valve; for flow rate regulation
- 8) Power cable
- 9) Control box
- 10) Pressure vessel
- 11) Pressure switch
- 12) Electro valve/electro-compressor

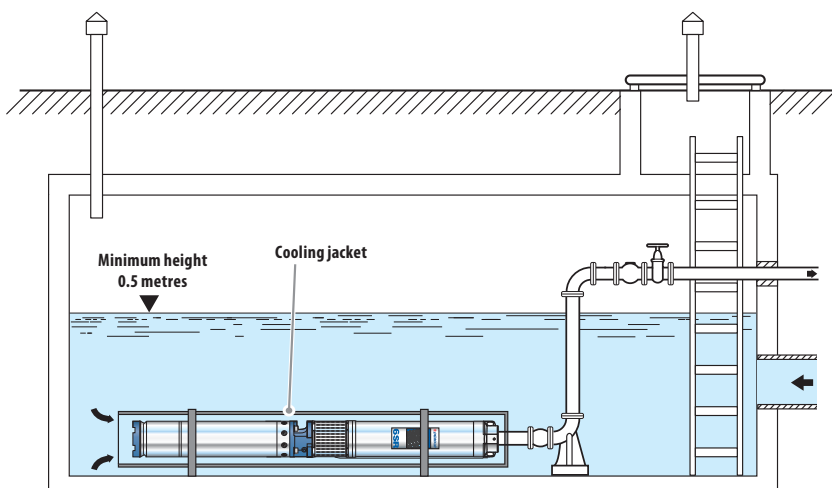

Cooling jacket

It is necessary to fit the pump with a cooling jacket in installations in storage tanks, rivers and lakes in order to prevent the motor from overheating.

POS.	DESCRIPTION	CONSTRUCTION CHARACTERISTICS
1	DELIVERY BODY	Stainless steel AISI 304 complete with threaded delivery port in compliance with ISO 228/1
2	NON-RETURN VALVE	Stainless steel AISI 304
3	MOTOR BRACKET	Nickel-plated cast iron, in compliance with NEMA standards
4	IMPELLERS	Special-rubber coated Noryl GFN2V
5	DIFFUSERS	Noryl GFN2V
6	DIFFUSOR CASING	Stainless steel AISI 304
7	PUMP SHAFT	Stainless steel AISI 304
8	PUMP BEARINGS	Special-technopolymer housing with stainless steel AISI 316, chrome oxide coated, sand resistant shaft bushing
9	DRIVE COUPLING	Stainless steel AISI 420
10	FILTER	Stainless steel AISI 304
11	CABLE COVER	Stainless steel AISI 304
12	MOTOR 6"	6PD = "PEDROLLO"

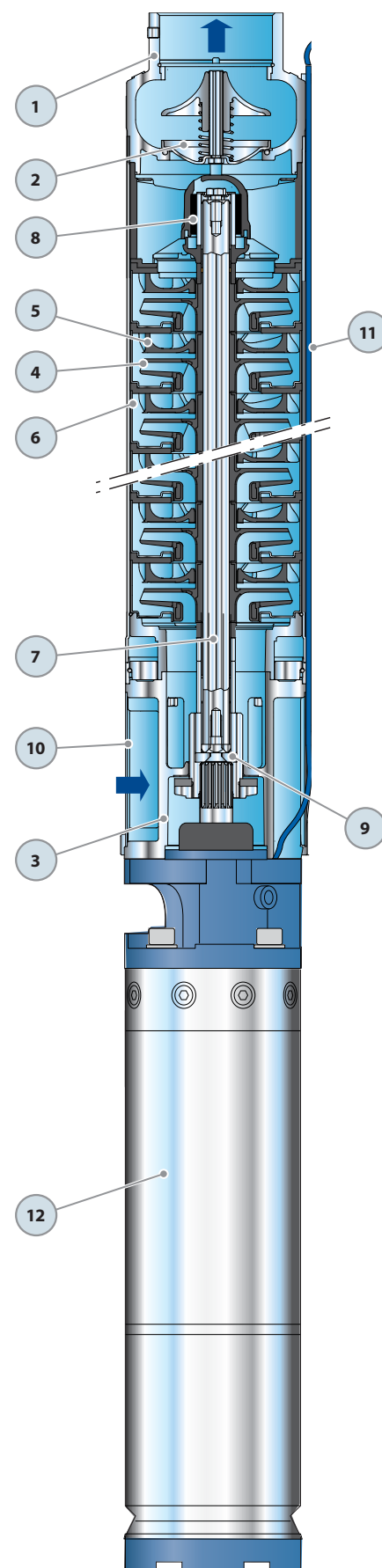

POS.	DESCRIPTION	CONSTRUCTION CHARACTERISTICS
1	DELIVERY BODY	Stainless steel AISI 304 complete with threaded delivery port in compliance with ISO 228/1
2	NON-RETURN VALVE	Stainless steel AISI 304
3	MOTOR BRACKET	Nickel-plated cast iron, in compliance with NEMA standards
4	IMPELLERS	Special-rubber coated Noryl GFN2V
5	DIFFUSERS	Noryl GFN2V
6	DIFFUSOR CASING	Stainless steel AISI 304
7	PUMP SHAFT	Stainless steel AISI 304
8	PUMP BEARINGS	Special-technopolymer housing with stainless steel AISI 316, chrome oxide coated, sand resistant shaft bushing
9	DRIVE COUPLING	Stainless steel AISI 420
10	FILTER	Stainless steel AISI 304
11	CABLE COVER	Stainless steel AISI 304
12	MOTOR 6"	6PD = "PEDROLLO"

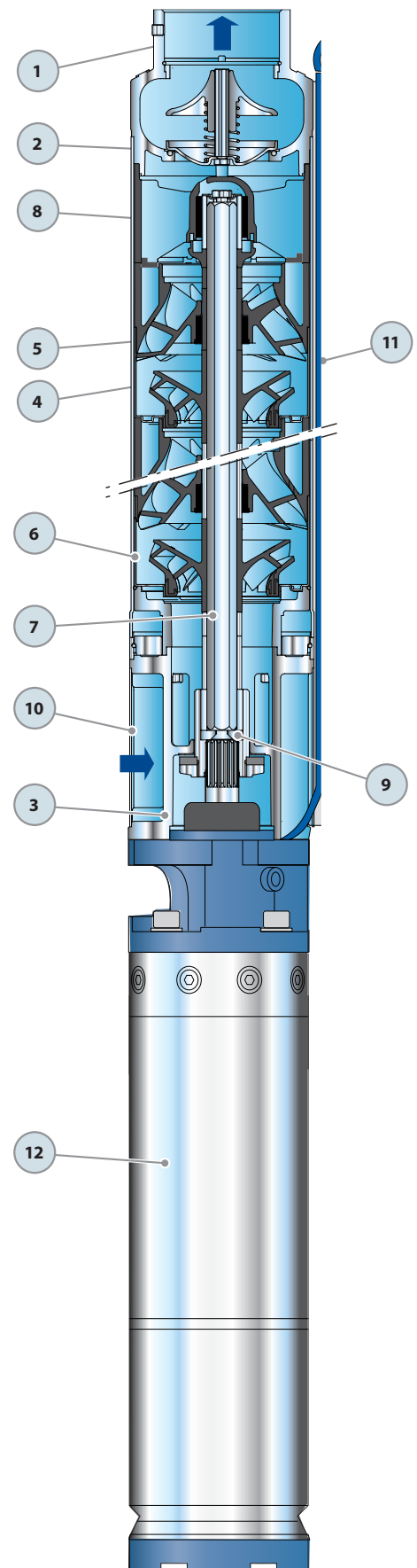

DIMENSIONS AND WEIGHT

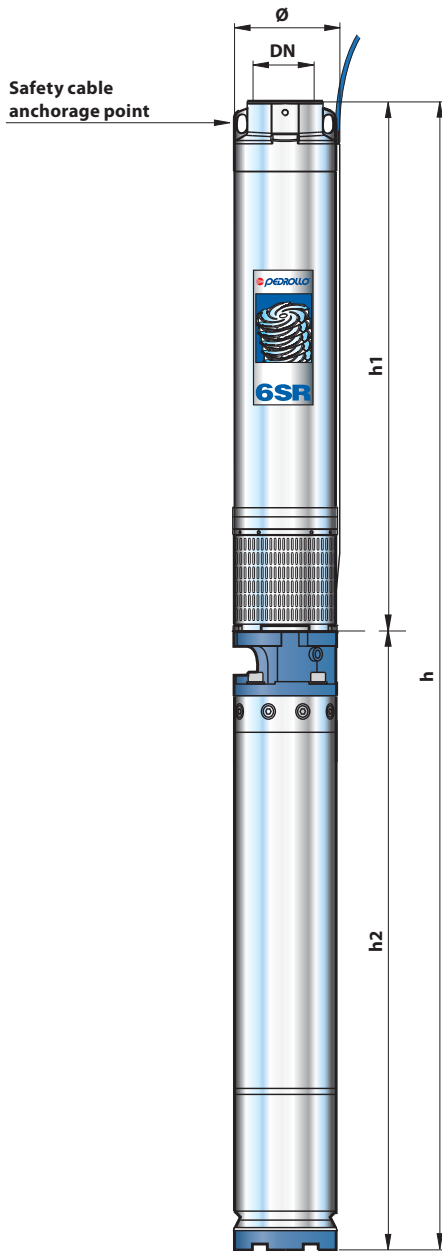

MODEL	PORT DN	Ø	DIMENSIONS mm			kg 3~
			h1	h2	h	
Three-phase						
6 SR 12/8 - PD	3"	149.5	719	633	1352	53.8
6 SR 12/11 - PD			849	667	1516	60.9
6 SR 12/15 - PD			1068	698	1766	66.8
6 SR 12/18 - PD			1198	731	1929	73.0
6 SR 12/21 - PD			1328	826	2154	83.9
6 SR 12/25 - PD			1502	894	2396	96.0
6 SR 12/28 - PD			1632	894	2526	98.1
6 SR 18/4 - PD			545	633	1178	49.6
6 SR 18/6 - PD			632	667	1299	53.6
6 SR 18/9 - PD			762	698	1460	60.3
6 SR 18/11 - PD			849	731	1580	67.0
6 SR 18/13 - PD			981	826	1807	76.9
6 SR 18/15 - PD			1068	894	1962	84.6
6 SR 18/18 - PD			1198	894	2092	87.6
6 SR 18/22 - PD			1371	959	2330	99.7
6 SR 18/26 - PD			1545	1116	2661	125.7
6 SR 27/4 - PD			583	633	1216	47.9
6 SR 27/5 - PD			636	667	1303	53.5
6 SR 27/7 - PD			742	698	1440	58.8
6 SR 27/8 - PD			795	731	1526	63.0
6 SR 27/10 - PD			901	826	1727	74.1
6 SR 27/12 - PD			1051	894	1945	83.6
6 SR 27/14 - PD			1157	894	2051	85.9
6 SR 27/17 - PD			1316	959	2275	97.5
6 SR 27/20 - PD			1474	1116	2590	123.0
6 SR 27/27 - PD			1845	1243	3088	135.8
6 SR 36/4 - PD			823	633	1456	55.4
6 SR 36/6 - PD			1049	667	1716	64.0
6 SR 36/8 - PD			1275	698	1973	71.0
6 SR 36/10 - PD			1501	731	2232	76.2
6 SR 36/11 - PD			1613	826	2439	90.0
6 SR 36/13 - PD			1839	894	2733	102.0
6 SR 36/15 - PD			2065	894	2959	107.0
6 SR 36/19 - PD			2517	959	3476	121.0
6 SR 36/23 - PD			2969	1116	4085	154.0
6 SR 44/3 - PD			710	633	1343	54.0
6 SR 44/4 - PD			823	667	1490	57.5
6 SR 44/5 - PD			936	698	1634	63.1
6 SR 44/6 - PD			1049	731	1780	70.0
6 SR 44/8 - PD			1275	826	2101	82.2
6 SR 44/9 - PD			1388	894	2282	92.0
6 SR 44/11 - PD			1613	894	2507	97.0
6 SR 44/13 - PD	1839	959	2798	110.0		
6 SR 44/16 - PD	2178	1116	3294	141.0		
6 SR 44/21 - PD	2743	1243	3986	154.3		

DIMENSIONS AND WEIGHT



MODEL	PORT DN	DIMENSIONS mm		kg
		Ø	h	
Pump				
6 SR 12/8 - HYD	3"	149.5	719	19.8
6 SR 12/11 - HYD			849	24.9
6 SR 12/15 - HYD			1068	27.8
6 SR 12/18 - HYD			1198	31.0
6 SR 12/21 - HYD			1328	33.9
6 SR 12/25 - HYD			1502	39.0
6 SR 12/28 - HYD			1632	41.1
6 SR 18/4 - HYD			545	15.6
6 SR 18/6 - HYD			632	17.6
6 SR 18/9 - HYD			762	21.3
6 SR 18/11 - HYD			849	25.0
6 SR 18/13 - HYD			981	26.9
6 SR 18/15 - HYD			1068	27.6
6 SR 18/18 - HYD			1198	30.6
6 SR 18/22 - HYD			1371	34.7
6 SR 18/26 - HYD			1545	38.7
6 SR 27/4 - HYD			583	13.9
6 SR 27/5 - HYD			636	17.5
6 SR 27/7 - HYD			742	19.8
6 SR 27/8 - HYD			795	21.0
6 SR 27/10 - HYD			901	24.1
6 SR 27/12 - HYD			1051	26.6
6 SR 27/14 - HYD			1157	28.9
6 SR 27/17 - HYD			1316	32.5
6 SR 27/20 - HYD			1474	36.0
6 SR 27/27 - HYD			1845	44.8
6 SR 36/4 - HYD			823	21.4
6 SR 36/6 - HYD			1049	28.0
6 SR 36/8 - HYD			1275	32.0
6 SR 36/10 - HYD			1501	34.2
6 SR 36/11 - HYD			1613	40.0
6 SR 36/13 - HYD			1839	45.0
6 SR 36/15 - HYD			2065	50.0
6 SR 36/19 - HYD			2517	56.0
6 SR 36/23 - HYD			2969	67.0
6 SR 44/3 - HYD			710	20.0
6 SR 44/4 - HYD			823	21.5
6 SR 44/5 - HYD			936	24.1
6 SR 44/6 - HYD			1049	28.0
6 SR 44/8 - HYD			1275	32.2
6 SR 44/9 - HYD			1388	35.0
6 SR 44/11 - HYD			1613	40.0
6 SR 44/13 - HYD	1839	45.0		
6 SR 44/16 - HYD	2178	54.0		
6 SR 44/21 - HYD	2743	63.3		



PERFORMANCE RANGE

- Powers from **0.37** to **7.5 kW**

APPLICATION LIMITS

- Maximum liquid temperature **+35 °C**
- **100 m** immersion limit
- Starts/hour: 20 at regular intervals
- Minimum flow rate for motor cooling **8 cm/s**
- Continuous service **S1**

ELECTRIC MOTOR

- 2 pole electric motor, 50 Hz (n ~ 2900 1/min)
- Voltage:
 - single-phase **230 V** up to 2.2 kW
 - three-phase **400 V**
- Insulation: F class • Protection: IP 68

CONSTRUCTION AND SAFETY STANDARDS

Rewindable submersible oil filled motor (oil type vegetable).
Flange coupling dimensions in compliance with **NEMA** standards.

Complete with power cable of the following length:

- **1.5 m** for powers from 0.37 to 1.5 kW
- **2.5 m** for powers from 2.2 to 5.5 kW
- **3.5 m** for power from 7.5 kW.

⇒ **Single-phase versions come with a capacitor included in the packaging.**

EN 60034-1
IEC 60034-1
CEI 2-3



CERTIFICATIONS



AM30



VspTECT-003

PATENTS - TRADE MARKS - MODELS

- Patent Pending n° PCT/IB2009/051491
(single-phase up to 0.75 kW; three-phase up to 1.1 kW).
- Registered Community Design n° 342159-0018
(single-phase up to 0.75 kW; three-phase up to 1.1 kW).

OPTIONALS AVAILABLE ON REQUEST

- Other voltages or 60 Hz frequency

GUARANTEE

1 year subject to terms and conditions

PERFORMANCE DATA

Single-phase versions

MODEL	Rated power		Axial load	Revs	Starting current Rated current	Efficiency	Power factor	Rated torque	Starting torque Rated torque	Capacitor (Vc=450V)	h	Weight
	P2 kW	HP										
230 V / 50 Hz												
4PDm / 0.50	0.37	0.50	1500	2800	2.6	60%	0.94	1.3	0.7	16	304	7.3
4PDm / 0.75	0.55	0.75		2803	2.9	62%	0.95	1.9	0.74	20	329	8.6
4PDm / 1	0.75	1		2824	3	63%	0.85	2.5	0.72	31.5	354	9.7
4PDm / 1.5	1.1	1.5	2500	2825	3.1	62%	0.9	3.7	0.82	40	434	12.0
4PDm / 2	1.5	2		2810	3.2	66%	0.93	5.1	0.8	50	467	13.6
4PDm / 3	2.2	3		2820	4.1	68%	0.97	7.51	0.77	76	565	18.2

Three-phase versions

MODEL	Rated power		Axial load	Revs	Starting current Rated current	Efficiency	Power factor	Rated torque	Starting torque Rated torque	h	Weight
	P2 kW	HP									
400 V / 50 Hz											
4PD / 0.50	0.37	0.50	1500	2808	4	62%	0.76	1.3	2.8	304	7.2
4PD / 0.75	0.55	0.75		2790	3	65%	0.85	2	1.8	304	7.2
4PD / 1	0.75	1		2790	3.7	69%	0.75	2.6	2.7	329	8.5
4PD / 1.5	1.1	1.5		2780	3.5	70%	0.79	3.9	2.4	354	10.4
4PD / 2	1.5	2	2500	2825	4.4	69%	0.76	5.07	2.9	428	11.1
4PD / 3	2.2	3		2820	4.4	74%	0.76	7.45	2.5	467	14.0
4PD / 4	3	4		2810	4.7	74%	0.78	10.18	2.7	522	15.6
4PD / 5.5	4	5.5	4500	2820	5.1	78%	0.77	13.53	3.1	587	18.8
4PD / 7.5	5.5	7.5		2845	5.4	80%	0.82	18.44	2.7	687	25.4
4PD / 10	7.5	10		2835	5.3	80%	0.3	25.26	2.6	768	29.2

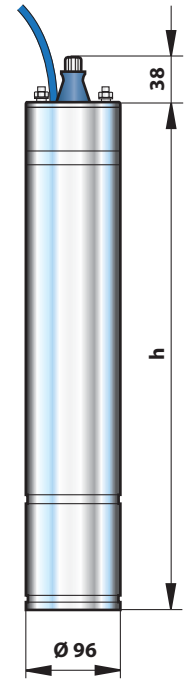

ABSORPTION

MODEL	VOLTAGE (single-phase)
Single-phase	230 V
4PDm / 0.50	3.1 A
4PDm / 0.75	4.9 A
4PDm / 1	6.4 A
4PDm / 1.5	8.6 A
4PDm / 2	10.6 A
4PDm / 3	14.6 A

MODEL	VOLTAGE (three-phase)			
Three-phase	230 V	400 V	240 V	415 V
4PD / 0.50	2.1 A	1.2 A	2.1 A	1.2 A
4PD / 0.75	2.8 A	1.6 A	2.9 A	1.7 A
4PD / 1	3.6 A	2.1 A	3.8 A	2.2 A
4PD / 1.5	5.0 A	2.9 A	5.2 A	3.0 A
4PD / 2	7.1 A	4.1 A	7.4 A	4.3 A
4PD / 3	9.9 A	5.7 A	10.4 A	6.0 A
4PD / 4	13.0 A	7.5 A	13.7 A	7.9 A
4PD / 5.5	17.0 A	9.8 A	17.8 A	10.3 A
4PD / 7.5	22.8 A	13.2 A	23.5 A	13.6 A
4PD / 10	29.2 A	16.9 A	29.9 A	17.3 A



PERFORMANCE RANGE

- Powers from **0.37** to **7.5 kW**

APPLICATION LIMITS

- Maximum liquid temperature **+35 °C**
- **100 m** immersion limit
- Starts/hour: 20 at regular intervals
- Minimum flow rate for motor cooling **8 cm/s**
- Continuous service **S1**

ELECTRIC MOTOR

- 2 pole electric motor, 50 Hz (n ~ 2900 1/min)
- Voltage:
 - single-phase **230 V** fino a 2.2 kW
 - three-phase **400 V**
- Insulation: B class
- Protection: IP 68

CONSTRUCTION AND SAFETY STANDARDS

Resin encapsulated windings.

Flange coupling dimensions in compliance with **NEMA** standards.

Complete with power cable of the following length:

- **1.5 m** for powers from 0.37 to 3 kW
- **2.5 m** for powers from 4 to 7.5 kW

⇒ **Capacitor not included for single-phase versions.**

EN 60034-1
IEC 60034-1
CEI 2-3



OPTIONALS AVAILABLE ON REQUEST

- Other voltages or 60 Hz frequency

GUARANTEE

1 year subject to terms and conditions

PERFORMANCE DATA

Single-phase versions

MODEL	Rated power		Axial load	Revs	Starting current / Rated current	Efficiency	Power factor	Rated torque	Starting torque / Rated torque	Capacitor (Vc=450V)	h	Weight
	P2 kW	HP										
230 V / 50 Hz												
4FKm / 0.50	0.37	0.50	1500	2860	3.3	53%	0.93	1.2	0.8	16	242	8.3
4FKm / 0.75	0.55	0.75		2855	3.7	63%	0.94	1.8	0.8	20	271	9.6
4FKm / 1	0.75	1		2855	3.7	60%	0.98	2.5	0.9	30	298	10.8
4FKm / 1.5	1.1	1.5	3000	2855	3.7	62%	0.94	3.7	0.8	40	327	12.1
4FKm / 2	1.5	2		2825	3.3	66%	0.95	5.1	0.7	50	356	13.5
4FKm / 3	2.2	3	4000	2810	3.4	65%	0.99	7.5	0.6	70	460	18

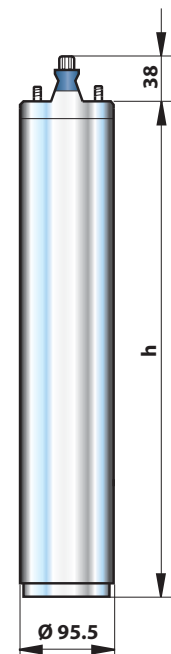

Three-phase versions

MODEL	Rated power		Axial load	Revs	Starting current / Rated current	Efficiency	Power factor	Rated torque	Starting torque / Rated torque	h	Weight
	P2 kW	HP									
400 V / 50 Hz											
4FK / 0.50	0.37	0.5	1500	2865	4.3	66%	0.7	1.2	2.1	223	7.3
4FK / 0.75	0.55	0.75		2855	4	67%	0.75	1.9	1.8	242	8.3
4FK / 1	0.75	1		2870	4.4	69%	0.75	2.5	2.1	271	9.6
4FK / 1.5	1.1	1.5	3000	2840	4.8	73%	0.76	3.7	2.9	298	10.8
4FK / 2	1.5	2		2855	4.8	73%	0.76	5	2.5	327	12.1
4FK / 3	2.2	3	4000	2840	4.9	75%	0.75	7.5	3.1	356	13.5
4FK / 4	3	4		2850	5.3	76%	0.75	9.9	3.2	423	16
4FK / 5.5	4	5.5	6500	2855	5.8	78%	0.78	13.7	3.4	583	24.1
4FK / 7.5	5.5	7.5		2850	6.0	76%	0.79	18.7	2.8	698	29.4
4FK / 10	7.5	10		2820	5.5	74%	0.79	25.1	3.6	774	33

ABSORPTION

MODEL	VOLTAGE (single-phase)
Single-phase	230 V
4FKm / 0.50	3.4 A
4FKm / 0.75	4.3 A
4FKm / 1	5.7 A
4FKm / 1.5	8.6 A
4FKm / 2	10.6 A
4FKm / 3	16.0 A

MODEL	VOLTAGE (three-phase)	
Three-phase	230 V	400 V
4FK / 0.50	1.9 A	1.1 A
4FK / 0.75	2.8 A	1.6 A
4FK / 1	3.6 A	2.1 A
4FK / 1.5	5.2 A	3.0 A
4FK / 2	6.9 A	4.0 A
4FK / 3	10.2 A	5.9 A
4FK / 4	13.5 A	7.8 A
4FK / 5.5	17.3 A	10.0 A
4FK / 7.5	23.7 A	13.7 A
4FK / 10	31.8 A	18.4 A



PERFORMANCE RANGE

- Powers from **4 to 30 kW**

APPLICATION LIMITS

- Maximum liquid temperature **+35 °C**
- **100 m** immersion limit
- Suitable for vertical and horizontal installations with operating limits as described for the 6SR submersible pump
- Starts/hour: 20 at regular intervals
- Minimum flow rate for motor cooling **16 cm/s** (0.5 m/s for 30 kW)
- Continuous service **S1**

ELECTRIC MOTOR

- 2 pole electric motor, 50 Hz (n ~ 2900 1/min)
- Three-phase voltage **400 V**
- Insulation: F class
- Protection: IP 68

CONSTRUCTION AND SAFETY STANDARDS

Rewindable submersible oil filled motor (oil type vegetable).
Flange coupling dimensions in compliance with **NEMA** standards.
Complete with **4 m** long power cable.

EN 60034-1
IEC 60034-1
CEI 2-3



CERTIFICATIONS



AM30



VspTECT-003

OPTIONALS AVAILABLE ON REQUEST

- Dual voltage 400/690 V (star/delta) motors from 11 kW to 30 kW
- Other voltages or 60 Hz frequency

GUARANTEE

1 year subject to terms and conditions

PERFORMANCE DATA

MODEL Three-phase 400 V / 50 Hz	Rated power P2		Axial load N	Revs 1/min	Starting current Rated current	Efficiency η	Power factor $\cos \varphi$	Rated torque Nm	Starting torque Rated torque	h mm	Weight kg
	kW	HP									
6PD / 5.5	4	5.5	10000	2840	4.6	79%	0.77	13.5	1.8	633	34
6PD / 7.5	5.5	7.5		2850	5.1	80%	0.74	18.4	2	667	36
6PD / 10	7.5	10		2835	5.2	81%	0.80	25.3	2	698	39
6PD / 12.5	9.2	12.5		2850	5.4	82%	0.78	30.8	2.3	731	42
6PD / 15	11	15		2895	5.5	82%	0.77	36.3	2.2	826	50
6PD / 20	15	20		2875	5.4	83%	0.78	49.8	2.1	894	57
6PD / 25	18.5	25		2870	6	84%	0.78	61.6	2.4	959	65
6PD / 30	22	30	20000	2890	5.9	85%	0.70	72.7	2.5	1116	87
6PD / 40	30	40		2850	6.2	85%	0.82	100.6	2.7	1243	91

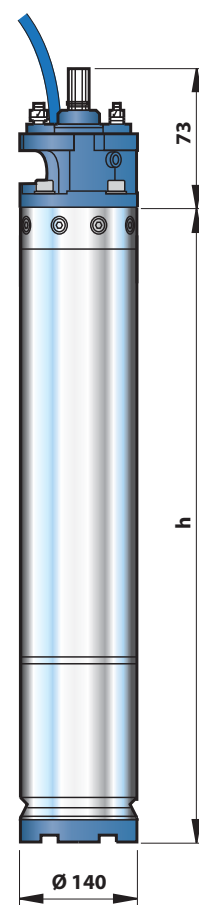

ABSORPTION

MODEL Three-phase	VOLTAGE (three-phase)	
	400 V	415 V
6PD / 5.5	9.5 A	9.6 A
6PD / 7.5	13.5 A	13.2 A
6PD / 10	16.8 A	17.1 A
6PD / 12.5	20.9 A	21.5 A
6PD / 15	25.3 A	26.6 A
6PD / 20	33.4 A	34.7 A
6PD / 25	40.7 A	42.1 A
6PD / 30	53.3 A	57.6 A
6PD / 40	61.9 A	62.2 A

Submersible DRAINAGE pump

for clear water



PERFORMANCE RANGE

- Flow rate up to **400 l/min** (24 m³/h)
- Head up to **14.5 m**

APPLICATION LIMITS

- Immersion limit:
 - **3 m** for TOP 1-2-3
 - **5 m** for TOP 4-5
- Maximum liquid temperature **+40 °C**
(Maximum liquid temperature +90 °C for a maximum of 3 minutes intermittent service)
- Passage of suspended solids up to **Ø 10 mm**
- Suction level:
 - **14 mm** above ground level for TOP 1-2-3
 - **30 mm** above ground level for TOP 4-5
- Continuous service **S1**

CONSTRUCTION AND SAFETY STANDARDS

Complete with:

- **5 m** long power cable for TOP 1-2-3
- **10 m** long power cable for TOP 4-5
- float switch

EN 60335-1
IEC 60335-1
CEI 61-150

EN 60034-1
IEC 60034-1
CEI 2-3



CERTIFICATIONS



AM30



VspTECT-003

INSTALLATION AND USE

The **TOP** series is suitable for use with **clear water** that does not contain abrasive particles.

As a result of the design solutions that have been adopted, such as the complete cooling of the motor and the shaft with double seal, these pumps are easy to use and reliable.

They are suitable for use in applications such as draining small flooded areas (rooms, cellars, garages) in the event of an emergency, for the disposal of waste water in the home (from dishwashers, washing machines) and for emptying drainage traps.

PATENTS - TRADE MARKS - MODELS

- Registered Community Design n° 342159-0011

OPTIONALS AVAILABLE ON REQUEST

- “**TOP - LA**” pumps intended for use with aggressive liquids
- Special mechanical seal
- TOP 1-2-3 pumps with **10 m** long power cable
 - ➔ N.B. Standard EN 60335-2-41 states that the power cable must be 10 m long for outdoor applications
- Pumps without float switch
- Other voltages or 60 Hz frequency

GUARANTEE

1 year subject to terms and conditions

CHARACTERISTIC CURVES AND PERFORMANCE DATA

50 Hz n= 2900 1/min

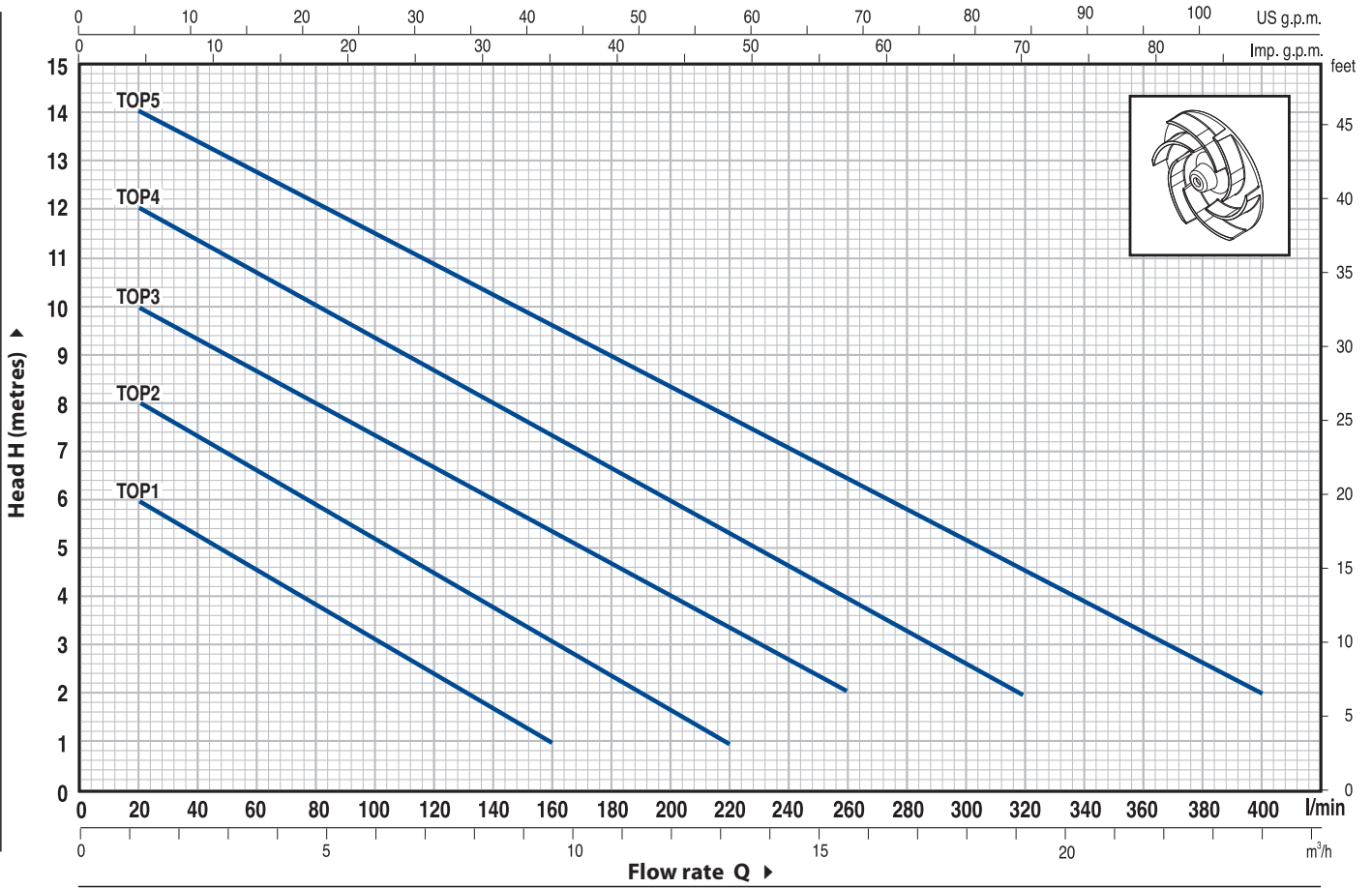

MODEL	POWER		Q	H metres																							
	kW	HP		0	1.2	2.4	3.6	4.8	6.0	7.2	8.4	9.6	10.8	12	13.2	14.4	15.6	16.8	18.0	19.2	20.4	21.6	22.8	24			
Single-phase			l/min	0	20	40	60	80	100	120	140	160	180	200	220	240	260	280	300	320	340	360	380	400			
TOP 1	0.25	0.33	H metres	7	6	5.5	4.5	4	3	2.5	1.5	1															
TOP 2	0.37	0.50	H metres	9	8	7.5	6.5	6	5.5	4.5	4	3	2.5	1.8	1												
TOP 3	0.55	0.75	H metres	10.5	10	9	8.8	8	7.5	6.5	6	5.5	4.8	4	3.5	2.5	2										
TOP 4	0.75	1	H metres	12.6	12	11.5	10.7	10	9.3	8.7	8	7.3	6.7	6	5.3	4.7	4	3.3	2.7	2							
TOP 5	0.92	1.25	H metres	14.5	14	13.5	12.7	12.1	11.5	10.8	10.2	9.6	8.9	8.3	7.7	7.1	6.4	5.8	5.2	4.5	3.9	3.3	2.6	2			

Q = Flow rate H = Total manometric head

Tolerance of characteristic curves in compliance with EN ISO 9906 App. A.

TOP 1-2-3

POS.	COMPONENT	CONSTRUCTION CHARACTERISTICS				
1	PUMP BODY	Technopolymer				
2	SUCTION FILTER	Technopolymer				
3	SUCTION PLATE	Stainless steel AISI 304				
4	DIFFUSER	Technopolymer				
5	IMPELLER	Noryl GFN2V				
6	MOTOR CASING	Stainless steel AISI 304				
7	MOTOR CASING PLATE	Stainless steel AISI 304				
8	MOTOR SHAFT	Stainless steel EN 10088-3 - 1.4104				
9	SHAFT WITH DOUBLE SEAL AND OIL CHAMBER					
	<i>Pump</i>	<i>Seal</i>	<i>Shaft</i>	<i>Materials</i>		
	<i>Model</i>	<i>Model</i>	<i>Diameter</i>	<i>Stationary ring</i>	<i>Rotational ring</i>	<i>Elastomer</i>
	TOP 1-2-3	AR-12R	Ø 12 mm	Ceramic	Graphite	NBR
	TOP 1-2-3 LA	AR-12R LA	Ø 12 mm	Ceramic	Graphite	NBR
10	LIP SEAL	Ø 12 x Ø 19 x H 5 mm				
11	BEARINGS	6201 ZZ / 6201 ZZ				
12	CAPACITOR					
	<i>Pump</i>	<i>Capacitance</i>				
	<i>Single-phase</i>	<i>(230 V or 240 V)</i>		<i>(110 V)</i>		
	TOP 1	6.3 µF 450 VL	16 µF 250 VL			
	TOP 2	10 µF 450 VL	16 µF 250 VL			
	TOP 3	14 µF 450 VL	16 µF 250 VL			
13	ELECTRIC MOTOR					
	<ul style="list-style-type: none"> - Single-phase 230 V - 50 Hz with thermal overload protector built-in to the winding - Insulation: F class - Protection: IP 68 					
14	HANDLE ASSEMBLY (resin sealed)					
	Complete with:					
	- 5 metre long "H07 RN-F" power cable with Schuko plug					
	- Float switch.					
15	HOSE CONNECTOR WITH UNION					
	Ø 25 mm hose connection for TOP 1					
	Ø 35 mm for TOP 2-3					

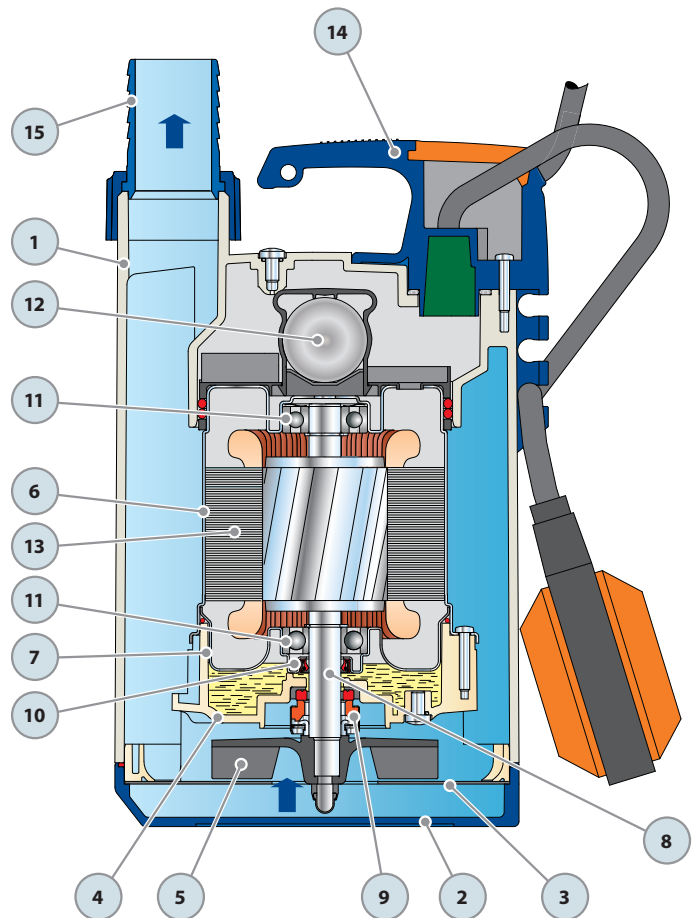

DIMENSIONS AND WEIGHT

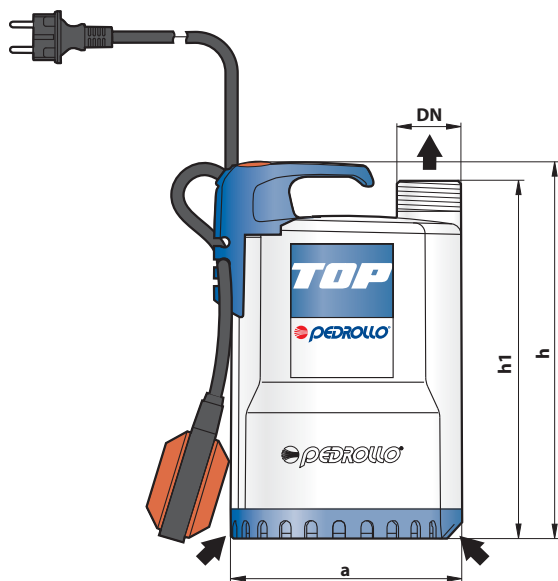

Typical installation

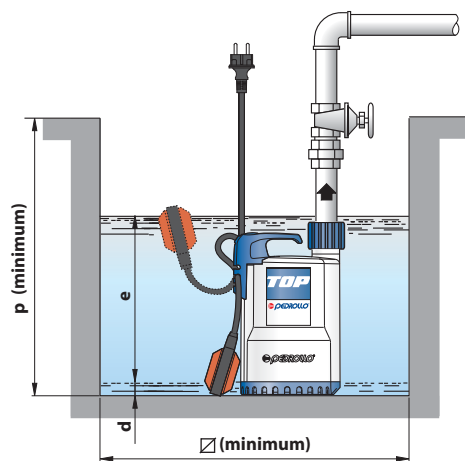

MODEL	PORT	DIMENSIONS mm							kg
		a	h	h1	d	e	p	Ø	
Single-phase	DN								
TOP 1	1 1/4"	152	257	237	14	variable	350	350	4.5
TOP 2				5.2					
TOP 3			287	267					6.6

ABSORPTION

MODEL	VOLTAGE (single-phase)		
	230 V	240 V	110 V
Single-phase			
TOP 1	1.3 A	1.3 A	3.0 A
TOP 2	2.0 A	2.0 A	5.3 A
TOP 3	3.2 A	3.2 A	7.9 A

PALLETIZATION

MODEL	GROUPAGE			CONTAINER		
	n° pumps	H (mm)	kg	n° pumps	H (mm)	kg
Single-phase						
TOP 1	96	1260	444	168	2100	765
TOP 2	96	1260	515	168	2100	888
TOP 3	96	1360	653	144	1970	971

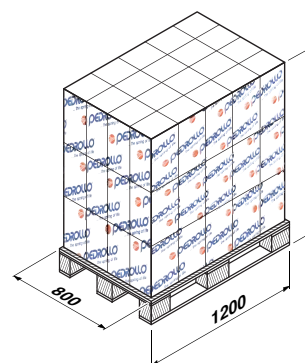

TOP 4-5

POS.	COMPONENT	CONSTRUCTION CHARACTERISTICS			
1	PUMP BODY	Technopolymer			
2	SUCTION FILTER	Technopolymer			
3	SUCTION PLATE	Stainless steel AISI 304			
4	DIFFUSER	Technopolymer			
5	IMPELLER	Ryton			
6	MOTOR CASING	Stainless steel AISI 304			
7	MOTOR CASING PLATE	Stainless steel AISI 304			
8	MOTOR SHAFT	Stainless steel EN 10088-3 - 1.4104			
9	SHAFT WITH DOUBLE SEAL AND OIL CHAMBER				
	<i>Seal</i>	<i>Shaft</i>	<i>Materials</i>		
	<i>Model</i>	<i>Diameter</i>	<i>Stationary ring</i>	<i>Rotational ring</i>	<i>Elastomer</i>
	MG1-14	Ø 14 mm	Ceramic	Graphite	NBR
10	LIP SEAL	Ø 16 x Ø 24 x H 5 mm			
11	BEARINGS	6203 ZZ / 6203 ZZ			
12	CAPACITOR				
	<i>Pump</i>	<i>Capacitance</i>			
	<i>Single-phase</i>	<i>(230 V or 240 V)</i>	<i>(110 V)</i>		
	TOP 4	16 µF 450 VL	30 µF 250 VL		
	TOP 5	20 µF 450 VL	30 µF 250 VL		
13	ELECTRIC MOTOR				
	<ul style="list-style-type: none"> - Single-phase 230 V - 50 Hz with thermal overload protector built-in to the winding - Insulation: F class - Protection: IP 68 				
14	HANDLE ASSEMBLY (resin sealed)				
	Complete with: <ul style="list-style-type: none"> - 10 metre long "H07 RN-F" power cable with Schuko plug - Float switch. 				
15	HOSE CONNECTOR WITH UNION				
	Hose connection Ø 41 mm				
16	PIPE COUPLING				
	In technopolymer with 1½" thread and clapet valve				

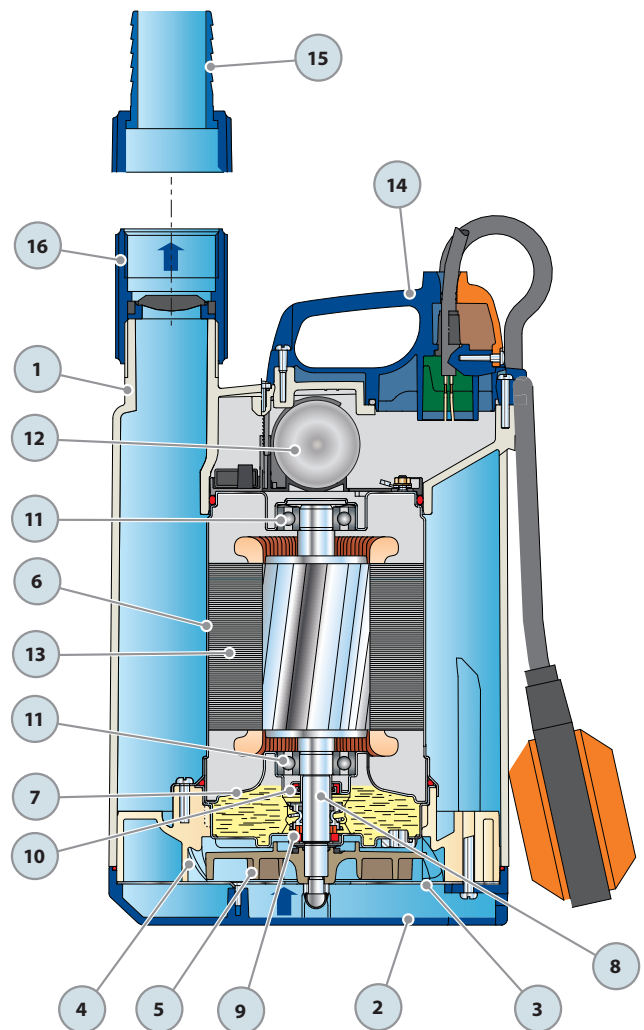

DIMENSIONS AND WEIGHT

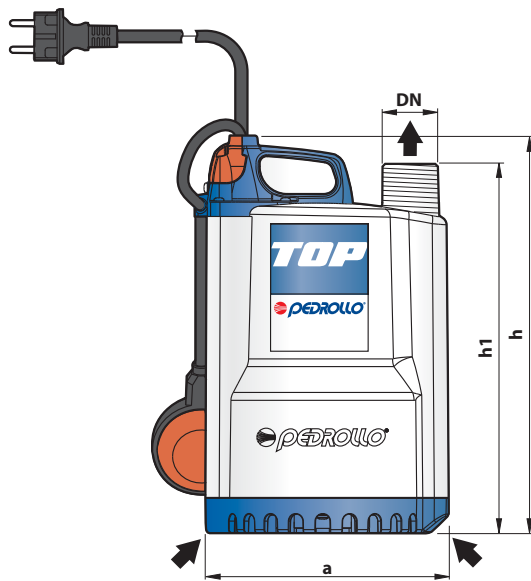

Typical installation

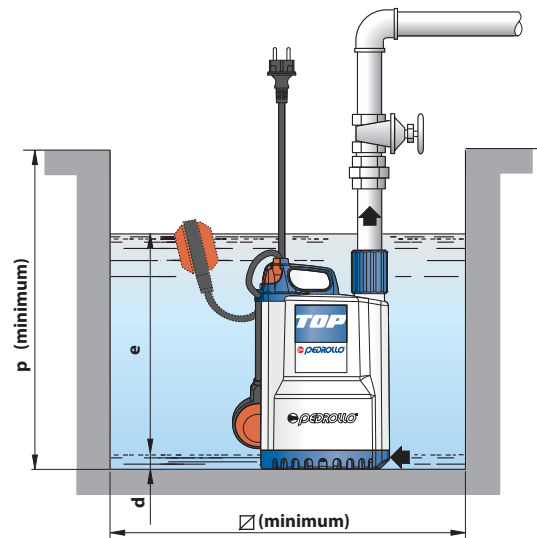

MODEL	PORT DN	DIMENSIONS mm							kg
		a	h	h1	d	e	p	∅	
Single-phase									
TOP 4	1½"	204	334	310	30	variable	450	450	10.1
TOP 5									11.1

ABSORPTION

MODEL	VOLTAGE (single-phase)		
	230 V	240 V	110 V
Single-phase			
TOP 4	4.8 A	4.8 A	9.6 A
TOP 5	6.5 A	6.5 A	13.0 A

PALLETIZATION

MODEL	GROUPAGE			CONTAINER		
	n° pumps	H (mm)	kg	n° pumps	H (mm)	kg
Single-phase						
TOP 4	54	1295	563	90	2065	928
TOP 5	54	1295	617	90	2065	1016

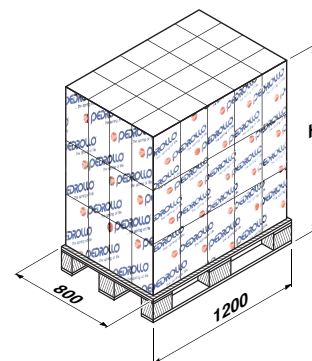

TOP-GM

Submersible DRAINAGE pump

⇒ for clear water



Version with vertical magnetic float switch



PERFORMANCE RANGE

- Flow rate up to **260 l/min** (15.6 m³/h)
- Head up to **10.5 m**

APPLICATION LIMITS

- **3 m** maximum immersion depth
- Maximum liquid temperature **+40 °C**
(Maximum liquid temperature +90 °C for a maximum of 3 minutes intermittent service)
- Passage of suspended solids up to **Ø 10 mm**
- Suction down to **14 mm** above ground level
- Continuous service **S1**

CONSTRUCTION AND SAFETY STANDARDS

Complete with:

- **5 m** long power cable
- vertical magnetic float switch

EN 60335-1
IEC 60335-1
CEI 61-150

EN 60034-1
IEC 60034-1
CEI 2-3



CERTIFICATIONS



INSTALLATION AND USE

The **TOP-GM** series is suitable for use with **clear water** that does not contain abrasive particles and comes complete with a vertical float switch meaning that the pumps **can be used in particularly small spaces**.

As a result of the design solutions that have been adopted, such as the complete cooling of the motor and the shaft with double seal, these pumps are easy to use and reliable.

They are suitable for use in applications such as draining small flooded areas (rooms, cellars, garages) in the event of an emergency, for the disposal of waste water in the home (from dishwashers, washing machines) and for emptying drainage traps.

PATENTS - TRADE MARKS - MODELS

- Registered Community Design n° 342159-0011

OPTIONALS AVAILABLE ON REQUEST

- Special mechanical seal
- Pumps with a **10 m** long power cable
 - ⇒ N.B. Standard EN 60335-2-41 states that the power cable must be 10 m long for outdoor applications
- Other voltages or 60 Hz frequency

GUARANTEE

1 year subject to terms and conditions

CHARACTERISTIC CURVES AND PERFORMANCE DATA

50 Hz n= 2900 1/min

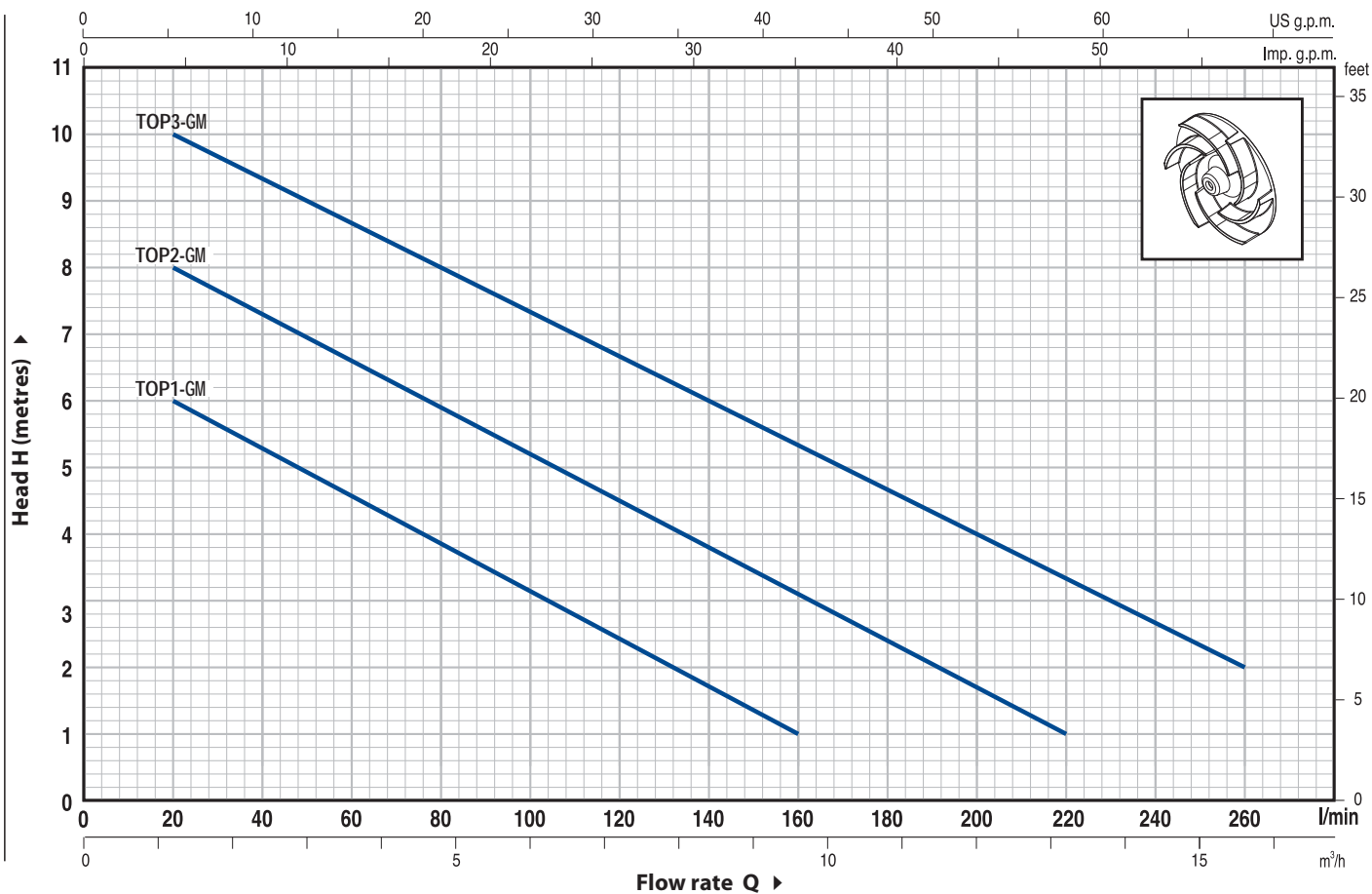

MODEL	POWER		Q	0	1.2	2.4	3.6	4.8	6.0	7.2	8.4	9.6	10.8	12	13.2	14.4	15.6
	kW	HP		0	20	40	60	80	100	120	140	160	180	200	220	240	260
Single-phase																	
TOP1-GM	0.25	0.33	H metres	7	6	5.5	4.5	4	3	2.5	1.8	1					
TOP2-GM	0.37	0.50		9	8	7.5	6.5	6	5.5	4.5	4	3	2.5	1.8	1		
TOP3-GM	0.55	0.75		10.5	10	9	8.8	8	7.5	6.5	6	5.5	4.8	4	3.5	2.5	2

Q = Flow rate H = Total manometric head

Tolerance of characteristic curves in compliance with EN ISO 9906 App. A.

POS.	COMPONENT	CONSTRUCTION CHARACTERISTICS			
1	PUMP BODY	Technopolymer			
2	SUCTION FILTER	Technopolymer			
3	SUCTION PLATE	Stainless steel AISI 304			
4	DIFFUSER	Technopolymer			
5	IMPELLER	Noryl GFN2V			
6	MOTOR CASING	Stainless steel AISI 304			
7	MOTOR CASING PLATE	Stainless steel AISI 304			
8	MOTOR SHAFT	Stainless steel EN 10088-3 - 1.4104			
9	SHAFT WITH DOUBLE SEAL AND OIL CHAMBER				
	<i>Seal</i>	<i>Shaft</i>	<i>Materials</i>		
	<i>Model</i>	<i>Diameter</i>	<i>Stationary ring</i>	<i>Rotational ring</i>	<i>Elastomer</i>
	AR-12R	Ø 12 mm	Ceramic	Graphite	NBR
10	LIP SEAL	Ø 12 x Ø 19 x H 5 mm			
11	BEARINGS	6201 ZZ / 6201 ZZ			
12	CAPACITOR				
	<i>Pump</i>	<i>Capacitance</i>			
	<i>Single-phase</i>	<i>(230 V or 240 V)</i>	<i>(110 V)</i>		
	TOP 1-GM	6.3 µF 450 VL	16 µF 250 VL		
	TOP 2-GM	10 µF 450 VL	16 µF 250 VL		
	TOP 3-GM	14 µF 450 VL	16 µF 250 VL		
13	ELECTRIC MOTOR				
	<ul style="list-style-type: none"> - Single-phase 230 V - 50 Hz with thermal overload protector built-in to the winding - Insulation: F class - Protection: IP 68 				
14	HANDLE ASSEMBLY (resin sealed)				
	Complete with: <ul style="list-style-type: none"> - 5 metre long "H07 RN-F" power cable with Schuko plug - Float switch. 				
15	HOSE CONNECTOR WITH UNION				
	Ø 25 mm hose connection for TOP 1 Ø 35 mm for TOP 2-3				

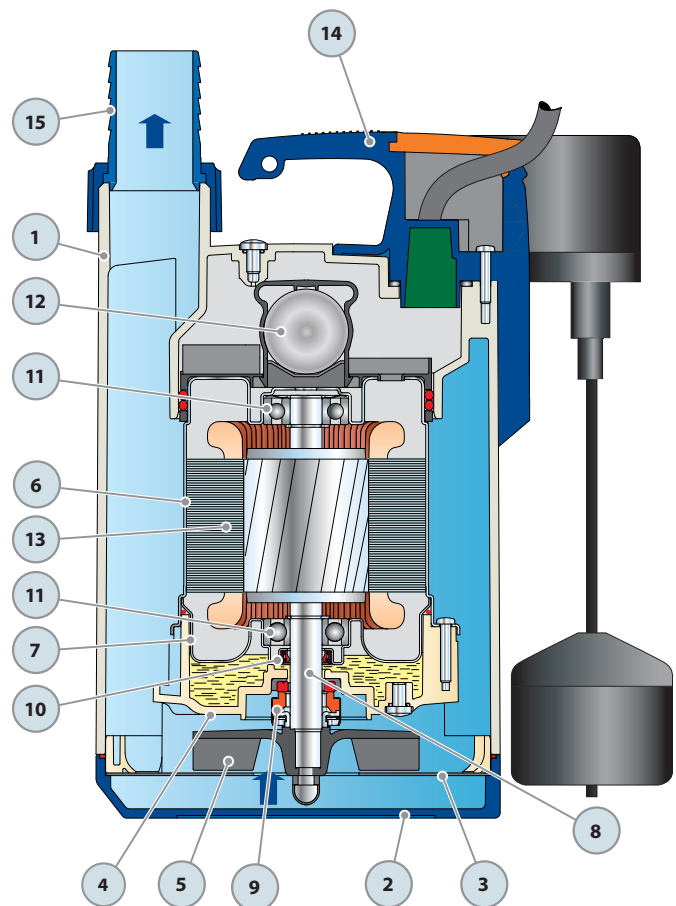

DIMENSIONS AND WEIGHT

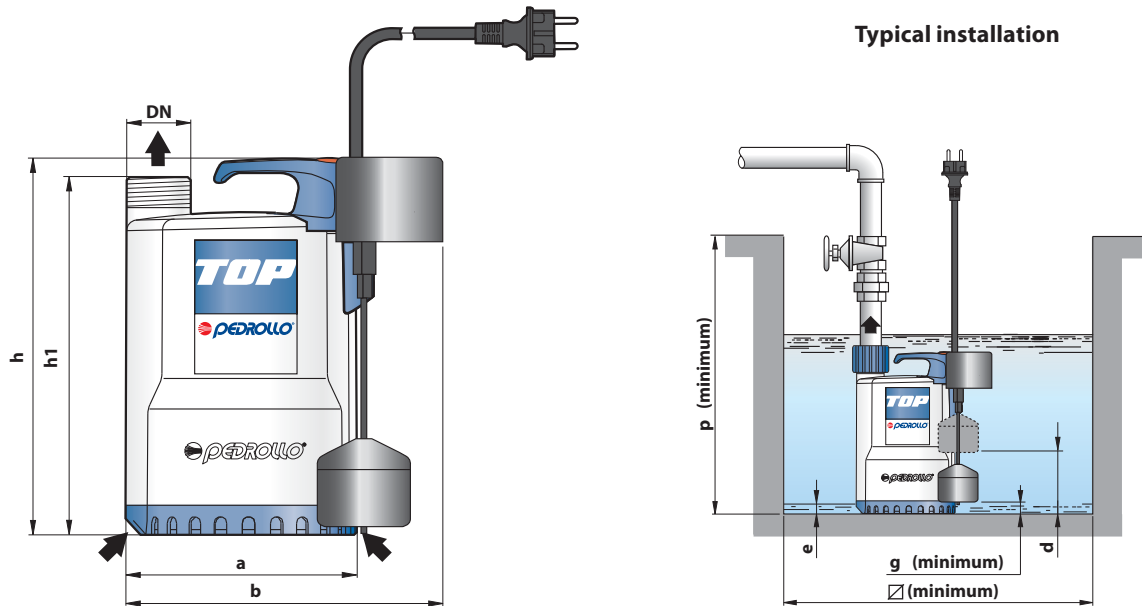

MODEL	PORT DN	DIMENSIONS mm									kg
		a	b	h	h1	d	e	g	p	Ø	
Single-phase											
TOP 1-GM	1¼"	152	200	257	237	14	105	25	350	220	4.6
TOP 2-GM				287	267		135				5.3
TOP 3-GM											6.7

ABSORPTION

MODEL	VOLTAGE (single-phase)		
	230 V	240 V	110 V
Single-phase			
TOP 1-GM	1.3 A	1.3 A	3.0 A
TOP 2-GM	2.0 A	2.0 A	5.3 A
TOP 3-GM	3.2 A	3.2 A	7.9 A

PALLETIZATION

MODEL	GROUPAGE			CONTAINER		
	n° pumps	H (mm)	kg	n° pumps	H (mm)	kg
Single-phase						
TOP 1-GM	96	1260	459	168	2100	790
TOP 2-GM	96	1260	526	168	2100	910
TOP 3-GM	96	1500	660	144	2180	982

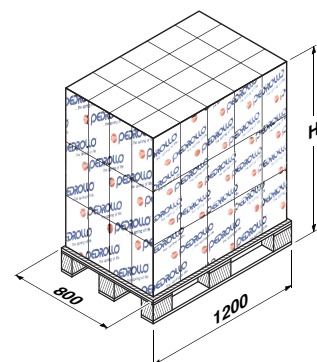

TOP-FLOOR

Submersible DRAINAGE pump

for clear water



PERFORMANCE RANGE

- Flow rate up to **160 l/min** (9.6 m³/h)
- Head up to **9 m**

APPLICATION LIMITS

- **3 m** maximum immersion depth
- Maximum liquid temperature **+40 °C**
(Maximum liquid temperature **+90 °C** for a maximum of 3 minutes intermittent service)
- Passage of suspended solids up to **Ø 2 mm**
- Suction down to **2 mm** above ground level
- Continuous service **S1**

CONSTRUCTION AND SAFETY STANDARDS

Complete with **5 m** long power cable

EN 60335-1
IEC 60335-1
CEI 61-150

EN 60034-1
IEC 60034-1
CEI 2-3



CERTIFICATIONS



INSTALLATION AND USE

The **TOP-FLOOR** series is suitable for use with **clear water** that does not contain abrasive particles.

As a result of their ability to drain water to a level of 2 millimetres above ground level, they are suitable for use in domestic emergencies where a small area must be drained to the lowest level possible.

PATENTS - TRADE MARKS - MODELS

- Registered Community Design n° 342159-0011

OPTIONALS AVAILABLE ON REQUEST

- Pumps with float switch
- Special mechanical seal
- Pumps with a **10 m** long power cable
 - ⇒ N.B. Standard EN 60335-2-41 states that the power cable must be 10 m long for outdoor applications
- Other voltages or 60 Hz frequency

GUARANTEE

1 year subject to terms and conditions

CHARACTERISTIC CURVES AND PERFORMANCE DATA

50 Hz n= 2900 1/min

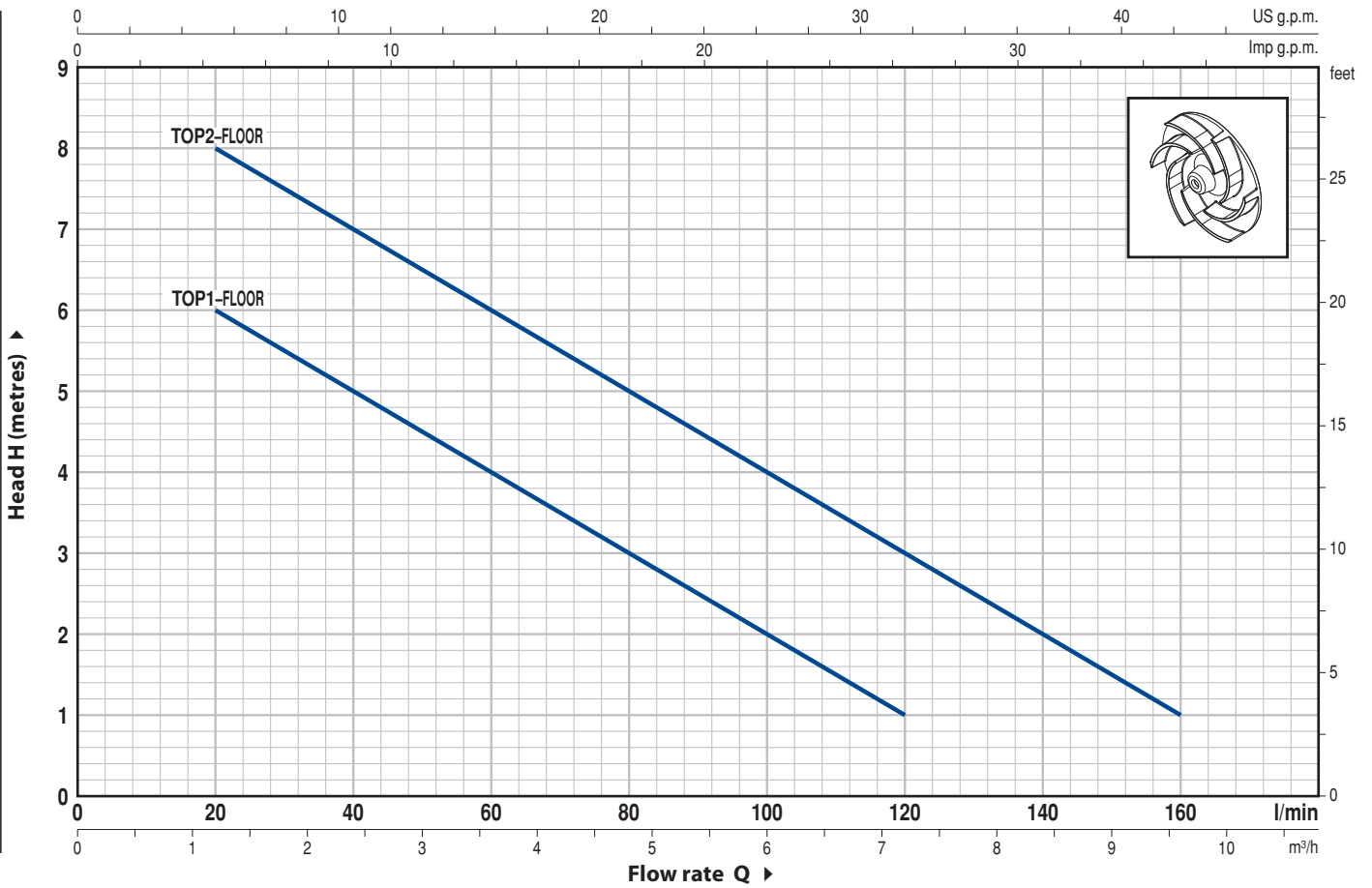

MODEL	POWER		Q	0	1.2	2.4	3.6	4.8	6.0	7.2	8.4	9.6
	kW	HP		0	20	40	60	80	100	120	140	160
Single-phase												
TOP1-FLOOR	0.25	0.33	H metres	7	6	5	4	3	2	1		
TOP2-FLOOR	0.37	0.50		9	8	7	6	5	4	3	2	1

Q = Flow rate H = Total manometric head

Tolerance of characteristic curves in compliance with EN ISO 9906 App. A.

TOP-FLOOR

POS.	COMPONENT	CONSTRUCTION CHARACTERISTICS	
1	PUMP BODY	Technopolymer	
2	SUCTION FILTER	Technopolymer	
3	SUCTION PLATE	Stainless steel AISI 304	
4	DIFFUSER	Technopolymer	
5	IMPELLER	Noryl GFN2V	
6	MOTOR CASING	Stainless steel AISI 304	
7	MOTOR CASING PLATE	Stainless steel AISI 304	
8	MOTOR SHAFT	Stainless steel EN 10088-3 - 1.4104	
9	SHAFT WITH DOUBLE SEAL AND OIL CHAMBER		
	<i>Seal</i>	<i>Shaft</i>	<i>Materials</i>
	<i>Model</i>	<i>Diameter</i>	<i>Stationary ring</i> <i>Rotational ring</i> <i>Elastomer</i>
	AR-12R	Ø 12 mm	Ceramic Graphite NBR
10	LIP SEAL	Ø 12 x Ø 19 x H 5 mm	
11	BEARINGS	6201 ZZ / 6201 ZZ	
12	CAPACITOR		
	<i>Pump</i>	<i>Capacitance</i>	
	<i>Single-phase</i>	<i>(230 V or 240 V)</i>	<i>(110 V)</i>
	TOP1-FLOOR	6.3 µF 450 VL	16 µF 250 VL
	TOP2-FLOOR	10 µF 450 VL	16 µF 250 VL
13	ELECTRIC MOTOR		
	<ul style="list-style-type: none"> - Single-phase 230 V - 50 Hz with thermal overload protector built-in to the winding - Insulation: F class - Protection: IP 68 		
14	HANDLE ASSEMBLY (resin sealed)		
	Complete with 5 metre long "H07 RN-F" power cable with Schuko plug		
15	HOSE CONNECTOR WITH UNION		
	Ø 25 mm hose connection for TOP1 - FLOOR		
	Ø 35 mm for TOP2 - FLOOR		

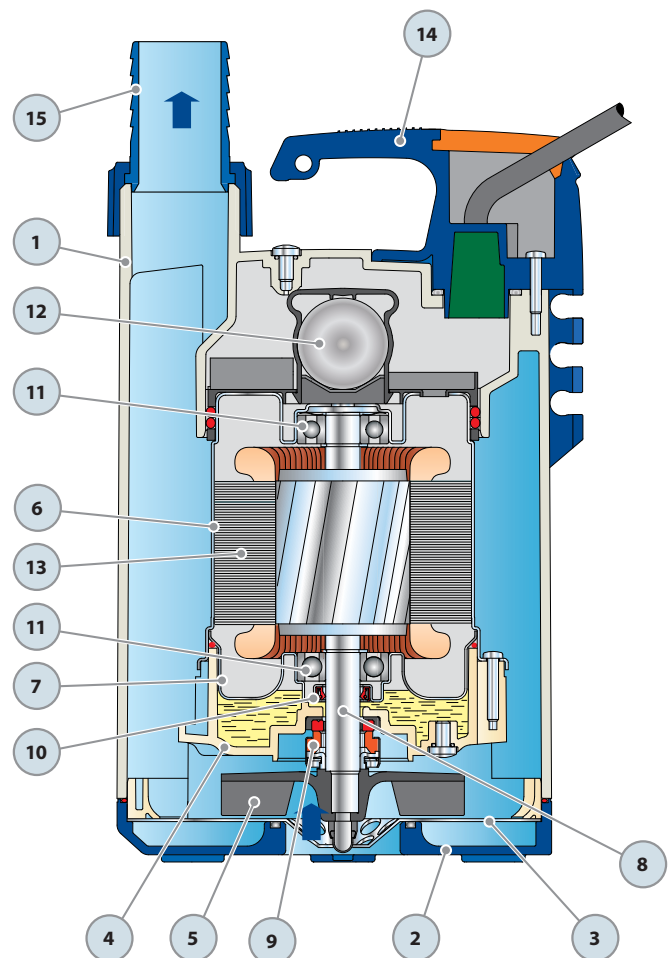

DIMENSIONS AND WEIGHT

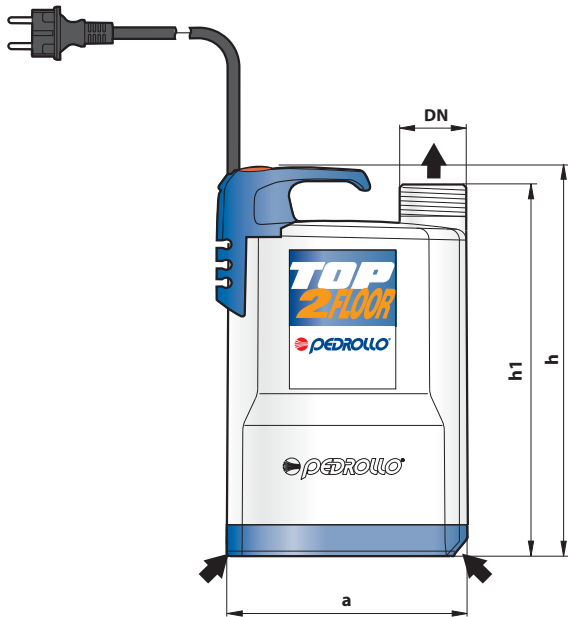

Typical installation

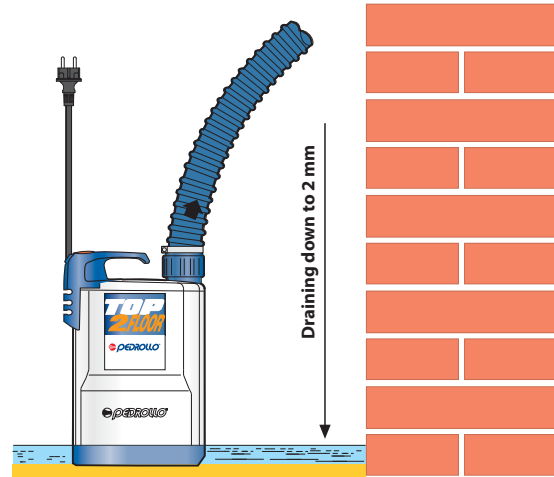

MODEL	PORT	DIMENSIONS mm			Minimum drying level	kg
Single-phase	DN	a	h	h1		
TOP1-FLOOR	1 1/4"	152	257	237	2 mm	4.3
TOP2-FLOOR						5.0

ABSORPTION

MODEL	VOLTAGE (single-phase)		
	230 V	240 V	110 V
Single-phase			
TOP1-FLOOR	1.3 A	1.3 A	3.0 A
TOP2-FLOOR	2.0 A	2.0 A	5.3 A

PALLETIZATION

MODEL	GROUPAGE			CONTAINER		
	n° pumps	H (mm)	kg	n° pumps	H (mm)	kg
Single-phase						
TOP1-FLOOR	96	1260	430	168	2100	739
TOP2-FLOOR	96	1260	500	168	2100	862

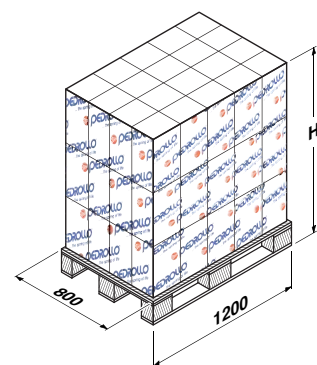

TOP-VORTEX

Submersible pumps

► for dirty water



PERFORMANCE RANGE

- Flow rate up to **180 l/min** (10.8 m³/h)
- Head up to **7 m**

APPLICATION LIMITS

- **3 m** maximum immersion depth
- Maximum liquid temperature **+40 °C**
(Maximum liquid temperature +90 °C for a maximum of 3 minutes intermittent service)
- Passage of suspended solids up to **Ø 20 mm**
- Suction down to **25 mm** above ground level
- Continuous service **S1**

CONSTRUCTION AND SAFETY STANDARDS

Complete with:
– **5 m** long power cable
– float switch

EN 60335-1
IEC 60335-1
CEI 61-150

EN 60034-1
IEC 60034-1
CEI 2-3



CERTIFICATIONS



INSTALLATION AND USE

The **TOP-VORTEX** pump is suitable for use with **dirty water** that is not chemically aggressive towards the materials from which the pump is made.

As a result of the design solutions that have been adopted, such as the complete cooling of the motor and the shaft with double seal, these pumps are easy to use and reliable.

They are suitable for use in applications such as clearing dirty water, emptying tanks, discharging domestic waste water, and for emptying collection traps containing suspended solids up to a maximum of Ø 20 mm.

PATENTS - TRADE MARKS - MODELS

- Registered Community Design n° 342159-0011

OPTIONALS AVAILABLE ON REQUEST

- Special mechanical seal
- Pumps with a **10 m** long power cable
► N.B. Standard EN 60335-2-41 states that the power cable must be 10 m long for outdoor applications
- Pumps without float switch
- Other voltages or 60 Hz frequency

GUARANTEE

1 year subject to terms and conditions

CHARACTERISTIC CURVES AND PERFORMANCE DATA

50 Hz n= 2900 1/min

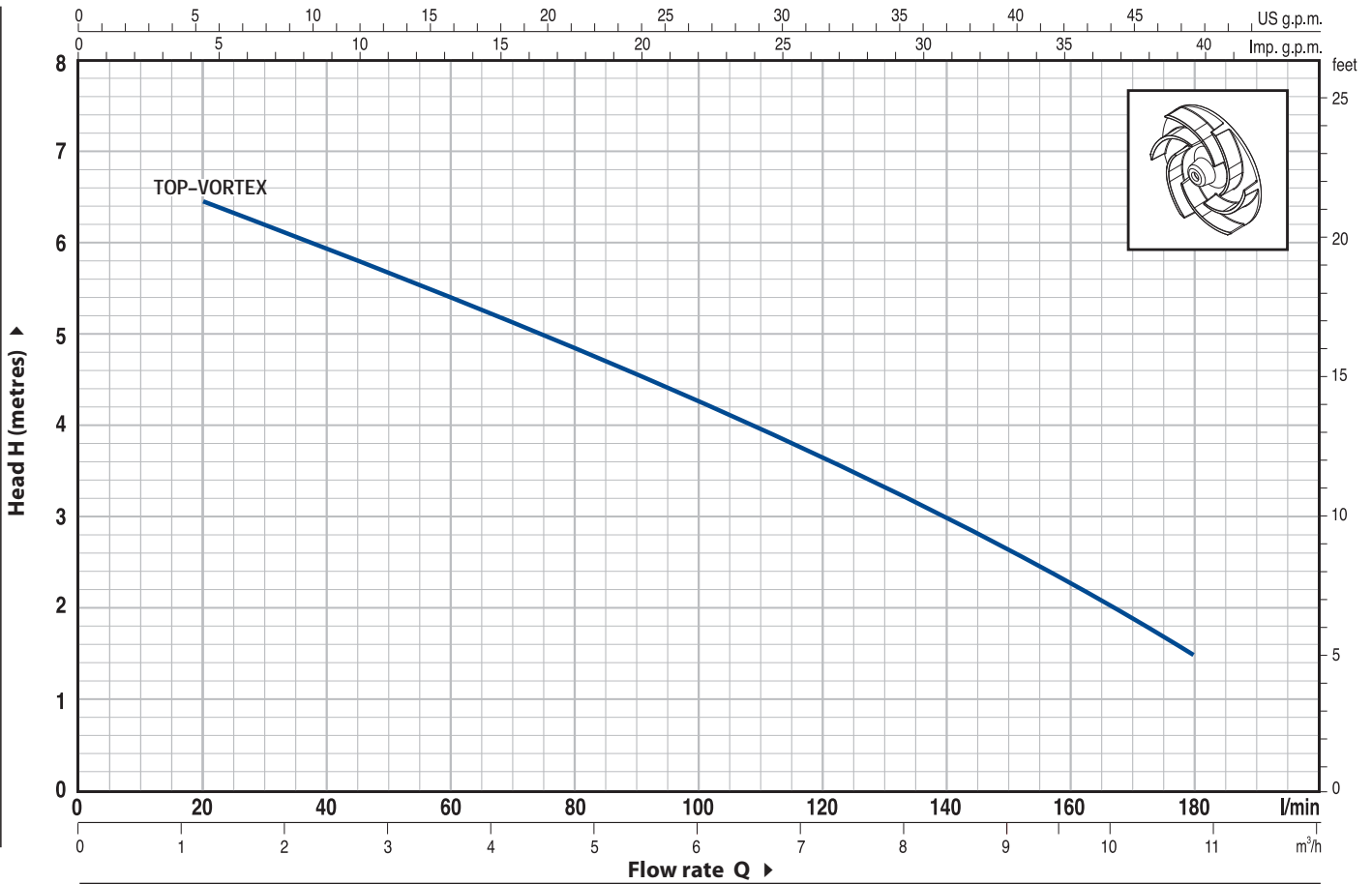

MODEL	POWER		Q	Flow rate											
	kW	HP		0	1.2	2.4	3.6	4.8	6.0	7.2	8.4	9.6	10.8		
Single-phase			l/min	0	20	40	60	80	100	120	140	160	180		
TOP-VORTEX	0.37	0.50	H metres	7	6.5	6	5.4	4.8	4.2	3.5	3	2.5	1.5		

Q = Flow rate H = Total manometric head

Tolerance of characteristic curves in compliance with EN ISO 9906 App. A.

TOP-VORTEX

POS.	COMPONENT	CONSTRUCTION CHARACTERISTICS	
1	PUMP BODY	Technopolymer	
2	SUCTION FILTER	Technopolymer	
3	SUCTION PLATE	Technopolymer	
4	DIFFUSER	Technopolymer	
5	IMPELLER	Technopolymer VORTEX type	
6	MOTOR CASING	Stainless steel AISI 304	
7	MOTOR CASING PLATE	Stainless steel AISI 304	
8	MOTOR SHAFT	Stainless steel EN 10088-3 - 1.4104	
9	SHAFT WITH DOUBLE SEAL AND OIL CHAMBER		
	<i>Seal</i>	<i>Shaft</i>	<i>Materials</i>
	<i>Model</i>	<i>Diameter</i>	<i>Stationary ring</i> <i>Rotational ring</i> <i>Elastomer</i>
	AR-12R	Ø 12 mm	Ceramic Graphite NBR
10	LIP SEAL	Ø 12 x Ø 19 x H 5 mm	
11	BEARINGS	6201 ZZ / 6201 ZZ	
12	CAPACITOR		
	<i>Capacitance</i>		
	(230 V or 240 V)	(110 V)	
	10 µF 450 VL	16 µF 250 VL	
13	ELECTRIC MOTOR		
	<ul style="list-style-type: none"> - Single-phase 230 V - 50 Hz with thermal overload protector built-in to the winding - Insulation: F class - Protection: IP 68 		
14	HANDLE ASSEMBLY (resin sealed)		
	Complete with: <ul style="list-style-type: none"> - 5 metre long "H07 RN-F" power cable with Schuko plug - Float switch. 		
15	HOSE CONNECTOR WITH UNION		
	Hose connection Ø 35 mm		

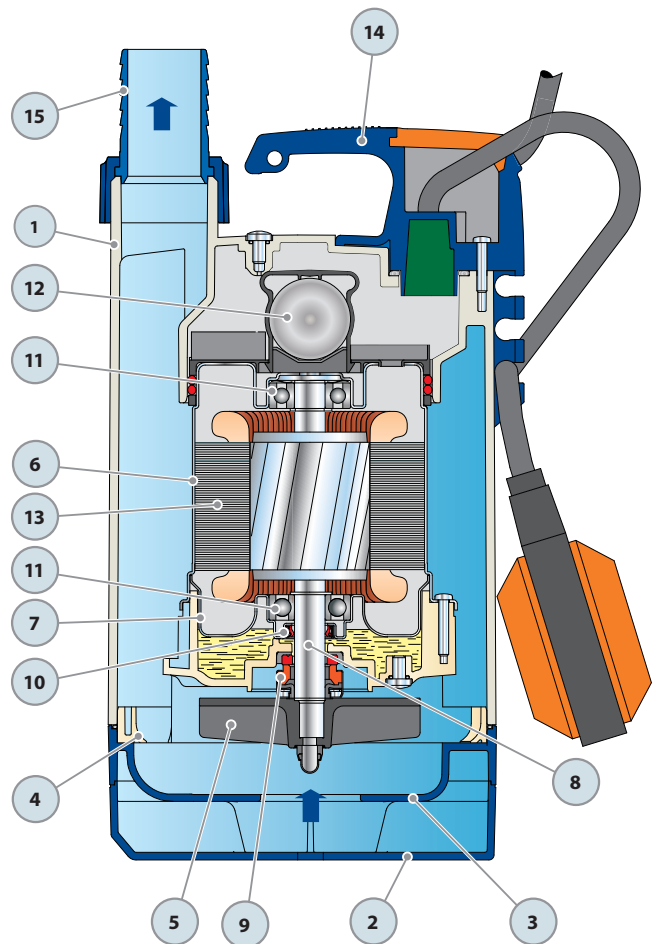

DIMENSIONS AND WEIGHT

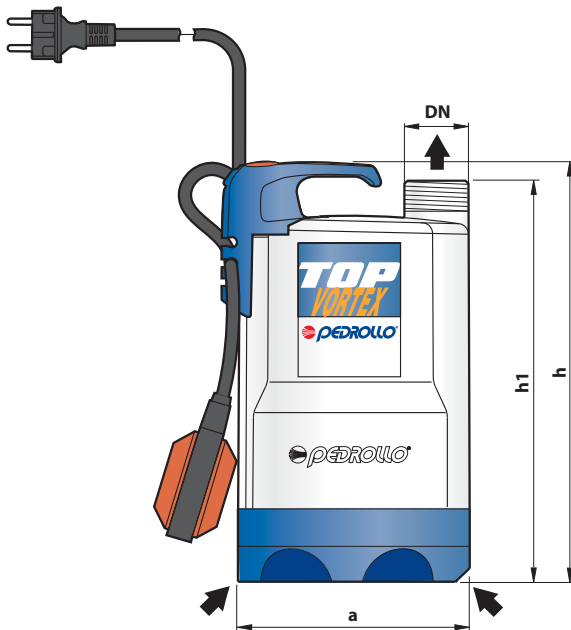

Typical installation

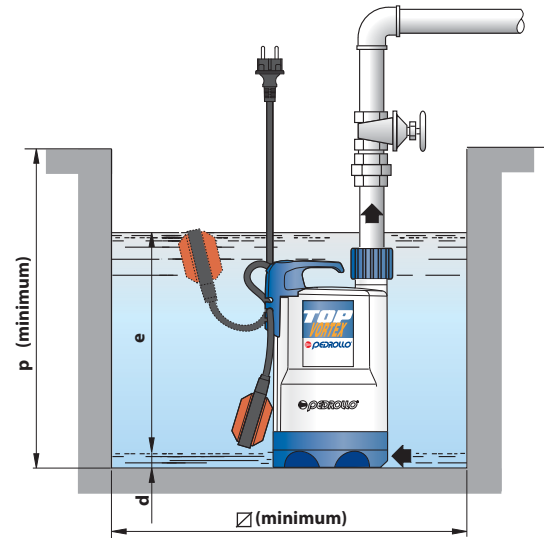

MODEL	PORT DN	DIMENSIONS mm							kg
		a	h	h1	d	e	p	∅	
Single-phase	1 1/4"	152	288	268	25	variable	350	350	5.1

ABSORPTION

MODEL	VOLTAGE (single-phase)		
	Single-phase	230 V	240 V
TOP-VORTEX	2.0 A	2.0 A	5.3 A

PALLETIZATION

MODEL	GROUPAGE			CONTAINER		
	n° pumps	H (mm)	kg	n° pumps	H (mm)	kg
Single-phase	96	1360	508	144	1970	753

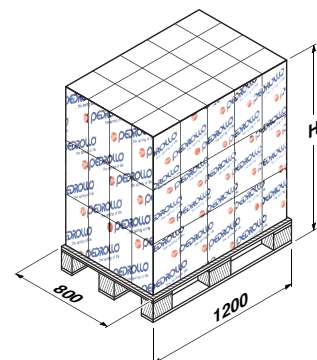

TOP-VORTEX/GM

Submersible pumps

► for dirty water



Version with vertical magnetic float switch

PERFORMANCE RANGE

- Flow rate up to **180 l/min** (10.8 m³/h)
- Head up to **7 m**

APPLICATION LIMITS

- **3 m** maximum immersion depth
- Maximum liquid temperature **+40 °C**
(Maximum liquid temperature +90 °C for a maximum of 3 minutes intermittent service)
- Passage of suspended solids up to **Ø 20 mm**
- Suction down to **25 mm** above ground level
- Continuous service **S1**

CONSTRUCTION AND SAFETY STANDARDS

Complete with:

- **5 m** long power cable
- vertical magnetic float switch

EN 60335-1
IEC 60335-1
CEI 61-150

EN 60034-1
IEC 60034-1
CEI 2-3



CERTIFICATIONS



INSTALLATION AND USE

The **TOP-VORTEX/GM** pump is suitable for use with **dirty water** and comes complete with a vertical float switch meaning that the pump can be used in particularly small spaces.

As a result of the design solutions that have been adopted, such as the complete cooling of the motor and the shaft with double seal, these pumps are easy to use and reliable.

They are suitable for use in applications such as clearing dirty water, emptying tanks, discharging domestic waste water, and for emptying small collection traps containing suspended solids up to a maximum of Ø 20 mm.

PATENTS - TRADE MARKS - MODELS

- Registered Community Design n° 342159-0011

OPTIONALS AVAILABLE ON REQUEST

- Special mechanical seal
- Pumps with a **10 m** long power cable
 - N.B. Standard EN 60335-2-41 states that the power cable must be 10 m long for outdoor applications
- Other voltages or 60 Hz frequency

GUARANTEE

1 year subject to terms and conditions

CHARACTERISTIC CURVES AND PERFORMANCE DATA

50 Hz n= 2900 1/min

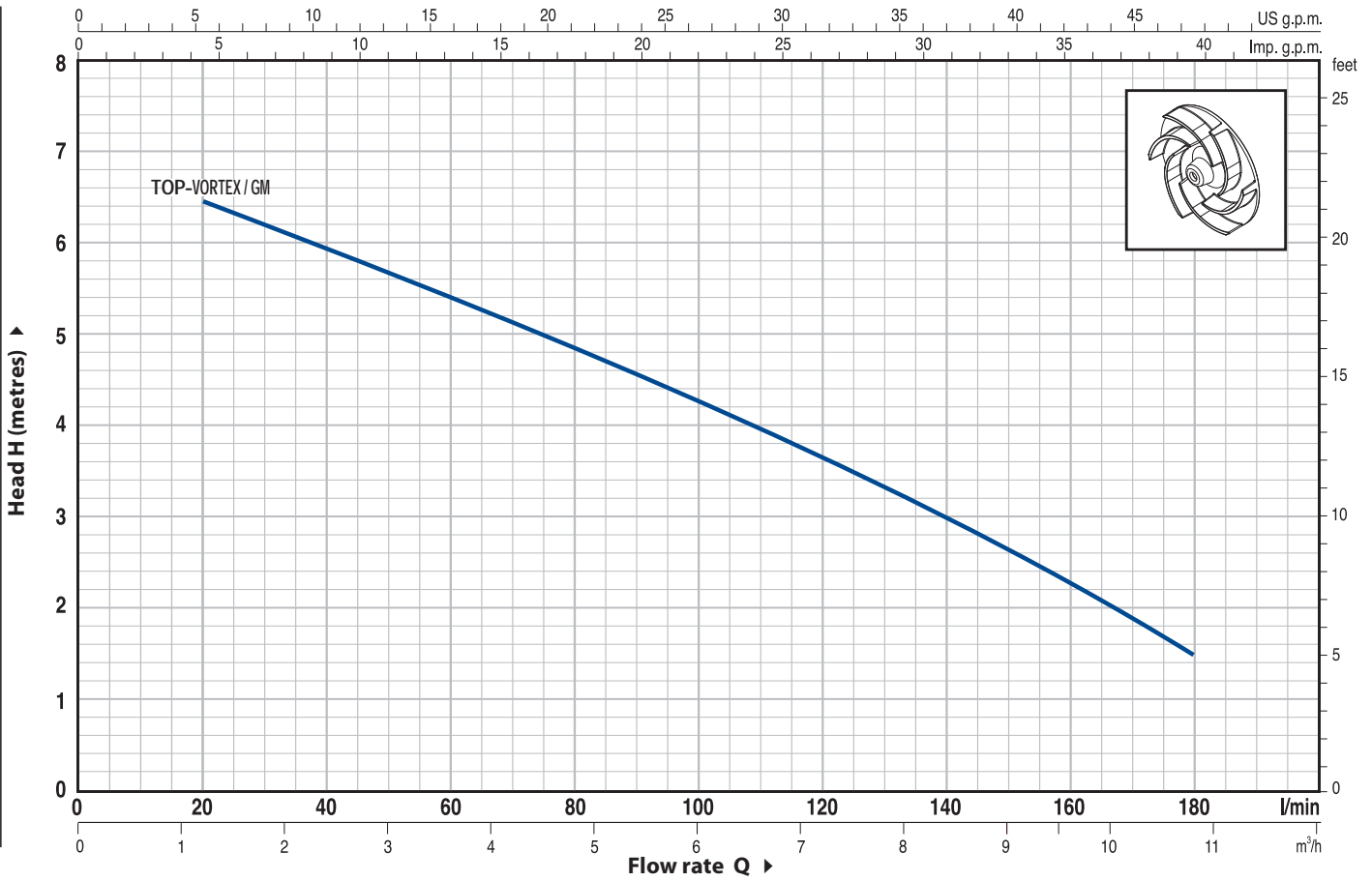

MODEL	POWER		Q	Flow rate											
	kW	HP		0	1.2	2.4	3.6	4.8	6.0	7.2	8.4	9.6	10.8		
Single-phase			l/min	0	20	40	60	80	100	120	140	160	180		
TOP-VORTEX/GM	0.37	0.50	H metres	7	6.5	6	5.4	4.8	4.2	3.5	3	2.5	1.5		

Q = Flow rate H = Total manometric head

Tolerance of characteristic curves in compliance with EN ISO 9906 App. A.

TOP-VORTEX/GM

POS.	COMPONENT	CONSTRUCTION CHARACTERISTICS
1	PUMP BODY	Technopolymer
2	SUCTION FILTER	Technopolymer
3	SUCTION PLATE	Technopolymer
4	DIFFUSER	Technopolymer
5	IMPELLER	Technopolymer VORTEX type
6	MOTOR CASING	Stainless steel AISI 304
7	MOTOR CASING PLATE	Stainless steel AISI 304
8	MOTOR SHAFT	Stainless steel EN 10088-3 - 1.4104
9	SHAFT WITH DOUBLE SEAL AND OIL CHAMBER	
	<i>Seal</i>	<i>Shaft</i>
	<i>Model</i>	<i>Diameter</i>
	<i>AR-12R</i>	$\varnothing 12$ mm
		<i>Stationary ring</i>
		Ceramic
		<i>Rotational ring</i>
		Graphite
		<i>Elastomer</i>
		NBR
10	LIP SEAL	$\varnothing 12 \times \varnothing 19 \times H 5$ mm
11	BEARINGS	6201 ZZ / 6201 ZZ
12	CAPACITOR	
	<i>Capacitance</i>	
	<i>(230 V or 240 V)</i>	<i>(110 V)</i>
	10 μ F 450 VL	16 μ F 250 VL
13	ELECTRIC MOTOR	
	<ul style="list-style-type: none"> - Single-phase 230 V - 50 Hz with thermal overload protector built-in to the winding - Insulation: F class - Protection: IP 68 	
14	HANDLE ASSEMBLY (resin sealed)	
	Complete with: <ul style="list-style-type: none"> - 5 metre long "H07 RN-F" power cable with Schuko plug - Float switch. 	
15	HOSE CONNECTOR WITH UNION	
	Hose connection $\varnothing 35$ mm	

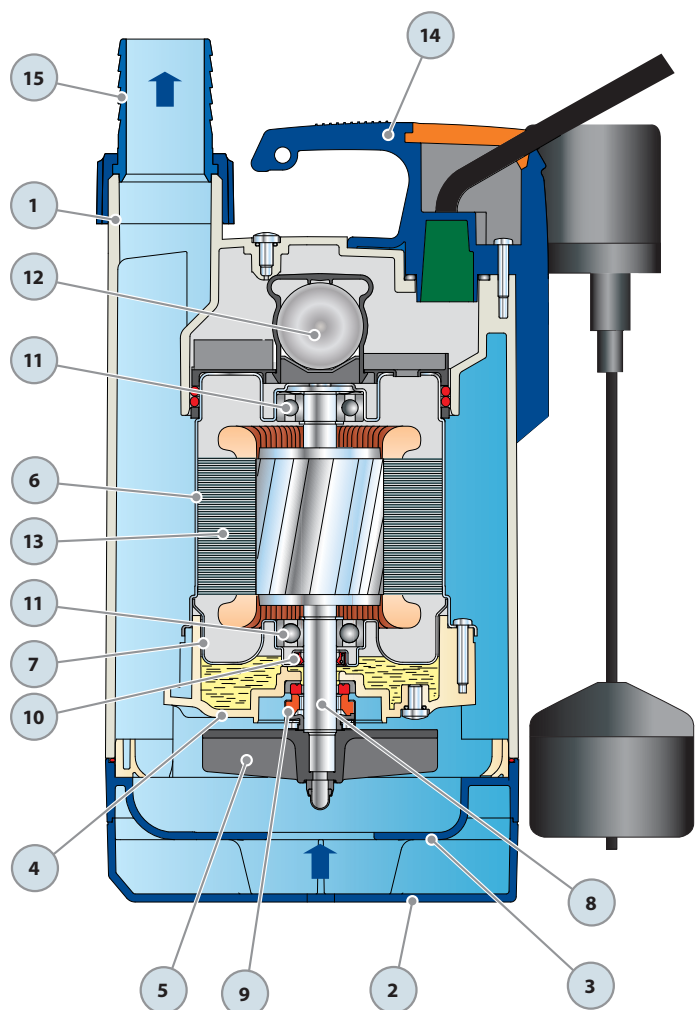

DIMENSIONS AND WEIGHT

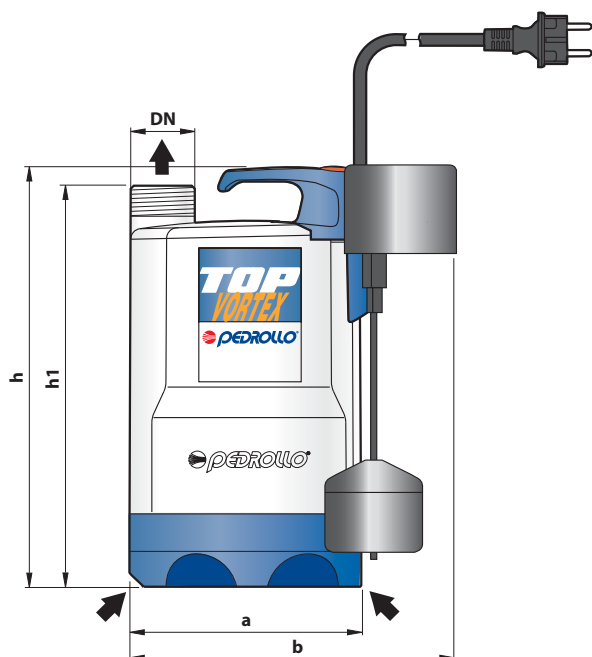

Typical installation

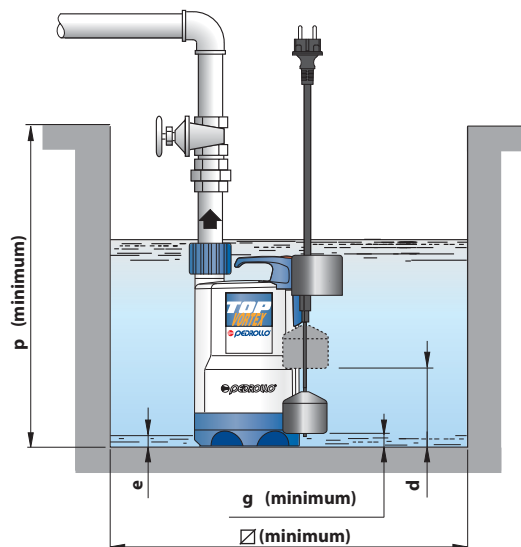

MODEL	PORT	DIMENSIONS mm									kg	
		a	b	h	h1	d	e	g	p	Ø		
Single-phase	DN											
TOP-VORTEX/GM	1 1/4"	152	200	288	268	25	135	25	350	220	5.2	

ABSORPTION

MODEL	VOLTAGE (single-phase)		
	Single-phase	230 V	240 V
TOP-VORTEX/GM	2.0 A	2.0 A	5.3 A

PALLETIZATION

MODEL	GROUPAGE			CONTAINER		
	n° pumps	H (mm)	kg	n° pumps	H (mm)	kg
Single-phase						
TOP-VORTEX/GM	96	1360	520	144	1970	771

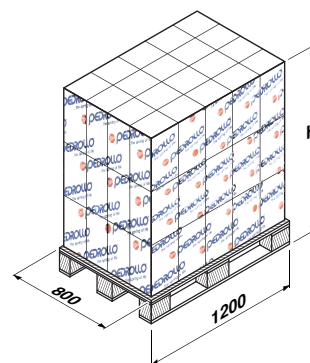

Submersible DRAINAGE pump

for clear water



PERFORMANCE RANGE

- Flow rate up to **300 l/min** (18 m³/h)
- Head up to **20 m**

APPLICATION LIMITS

- **10 m** maximum immersion depth
- Maximum liquid temperature **+50 °C**
(Maximum liquid temperature +90 °C for a maximum of 3 minutes intermittent service)
- Passage of suspended solids up to **Ø 10 mm**
- Suction level:
 - **14 mm** above ground level for RX 1-2-3
 - **25 mm** above ground level for RX 4-5
- Continuous service **S1**

CONSTRUCTION AND SAFETY STANDARDS

Complete with:

- **5 m** long power cable for RX1-2-3
- **10 m** long power cable for RX 4-5
- float switch for single-phase versions

EN 60335-1
IEC 60335-1
CEI 61-150

EN 60034-1
IEC 60034-1
CEI 2-3



CERTIFICATIONS



INSTALLATION AND USE

The **RX** series pumps are suitable for use with **clear water** that does not contain abrasive particles.

As a result of the design solutions that have been adopted, such as the complete cooling of the motor and the shaft with double seal, these pumps are easy to use and reliable.

They are suitable for use in fixed installations and applications such as draining small flooded areas (rooms, cellars, garages) in the event of an emergency, for the disposal of waste water in the home (from dishwashers, washing machines) and for emptying drainage traps.

PATENTS - TRADE MARKS - MODELS

- Registered Community Design n° 342159-0013 (RX 1-2-3)

OPTIONALS AVAILABLE ON REQUEST

- Special mechanical seal
- RX 1-2-3 pumps with a **10 m** long power cable.
 - ➔ N.B. Standard EN 60335-2-41 states that the power cable must be 10 m long for outdoor applications
- Single-phase pumps without float switch
- Other voltages or 60 Hz frequency

GUARANTEE

1 year subject to terms and conditions

CHARACTERISTIC CURVES AND PERFORMANCE DATA

50 Hz n= 2900 1/min

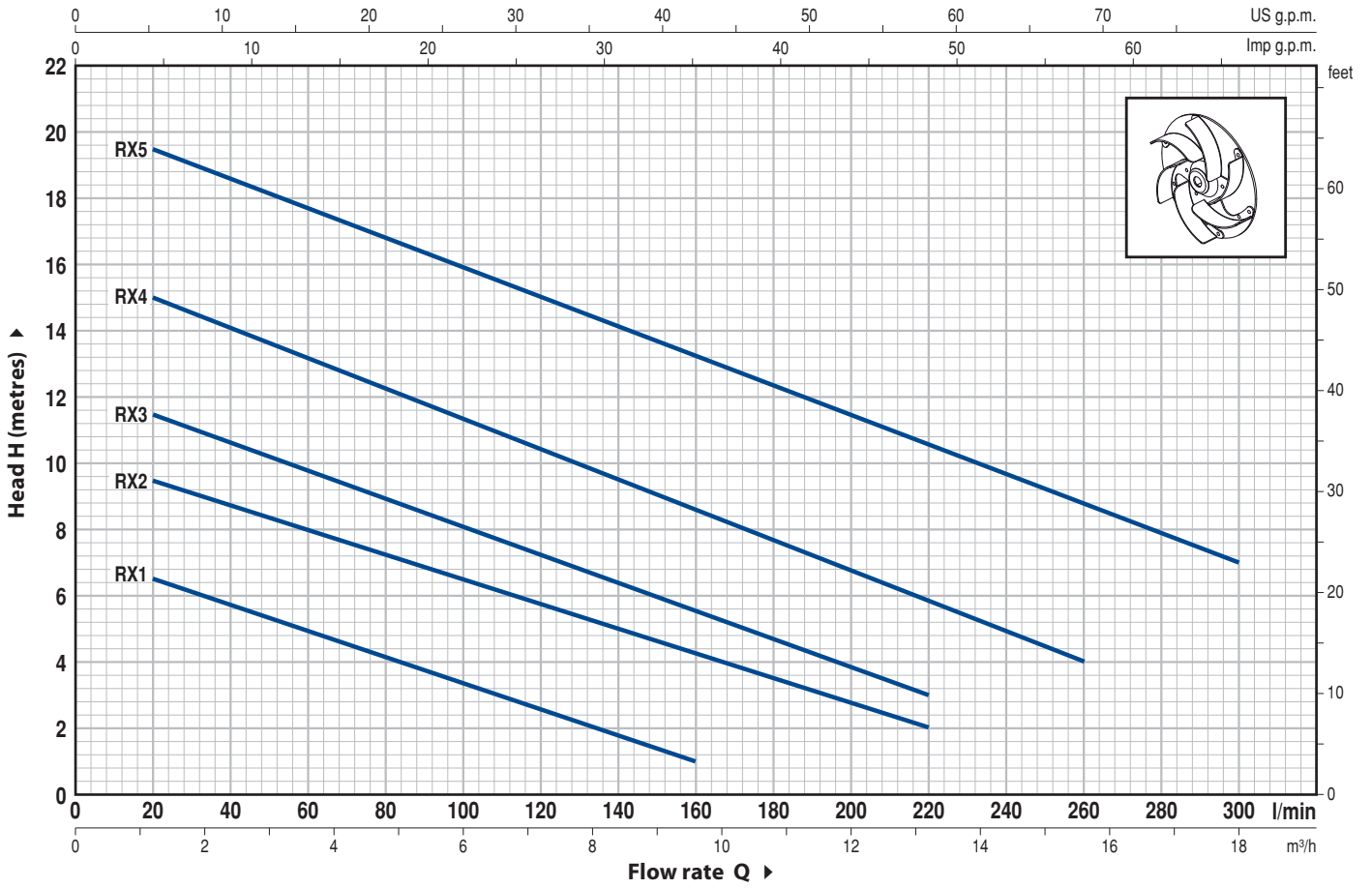

MODEL		POWER		Q	Flow rate													
Single-phase	Three-phase	kW	HP		m ³ /h	0	1.2	3.6	6.0	8.4	9.6	12.0	13.2	15.6	18.0			
				l/min	0	20	60	100	140	160	200	220	260	300				
RXm 1	-	0.25	0.33	H metres	7.5	6.5	5	3.5	2	1								
RXm 2	-	0.37	0.50		10	9.5	8	6.5	5	4.5	2.5	2						
RXm 3	-	0.55	0.75		12	11.5	9.5	8	6.5	5.5	3.5	3						
RXm 4	RX 4	0.75	1		16	15	13	11	9.5	8.5	6.5	5.5	4					
RXm 5	RX 5	1.1	1.5		20	19.5	17.5	16	14	13	11	10.5	8.5	7				

Q = Flow rate H = Total manometric head

Tolerance of characteristic curves in compliance with EN ISO 9906 App. A.

RX 1-2-3

POS.	COMPONENT	CONSTRUCTION CHARACTERISTICS	
1	PUMP BODY	Stainless steel AISI 304, with threaded port in compliance with ISO 228/1	
2	SUCTION FILTER	Stainless steel AISI 304	
3	SUCTION PLATE	Stainless steel AISI 304	
4	IMPELLER	Stainless steel AISI 304	
5	MOTOR CASING	Stainless steel AISI 304	
6	MOTOR CASING PLATE	Stainless steel AISI 304	
7	MOTOR SHAFT	Stainless steel EN 10088-3 - 1.4104	
8	SHAFT WITH DOUBLE SEAL AND OIL CHAMBER		
	<i>Seal</i>	<i>Shaft</i>	<i>Materials</i>
	<i>Model</i>	<i>Diameter</i>	<i>Stationary ring</i> <i>Rotational ring</i> <i>Elastomer</i>
	AR-12R	Ø 12 mm	Ceramic Graphite NBR
9	LIP SEAL	Ø 12 x Ø 19 x H 5 mm	

10	BEARINGS	
	6201 ZZ / 6201 ZZ	
11	CAPACITOR	
	<i>Pump</i>	<i>Capacitance</i>
	<i>Single-phase</i>	(230 V or 240 V) (110 V)
	RXm 1	6.3 µF 450 VL 16 µF 250 VL
	RXm 2	10 µF 450 VL 16 µF 250 VL
	RXm 3	14 µF 450 VL 16 µF 250 VL

12 ELECTRIC MOTOR

- Single-phase 230 V - 50 Hz with thermal overload protector built-in to the winding
- Insulation: F class
- Protection: IP 68

13 HANDLE ASSEMBLY (resin sealed)

Complete with:

- 5 metre long "H07 RN-F" power cable with Schuko plug
- Float switch.

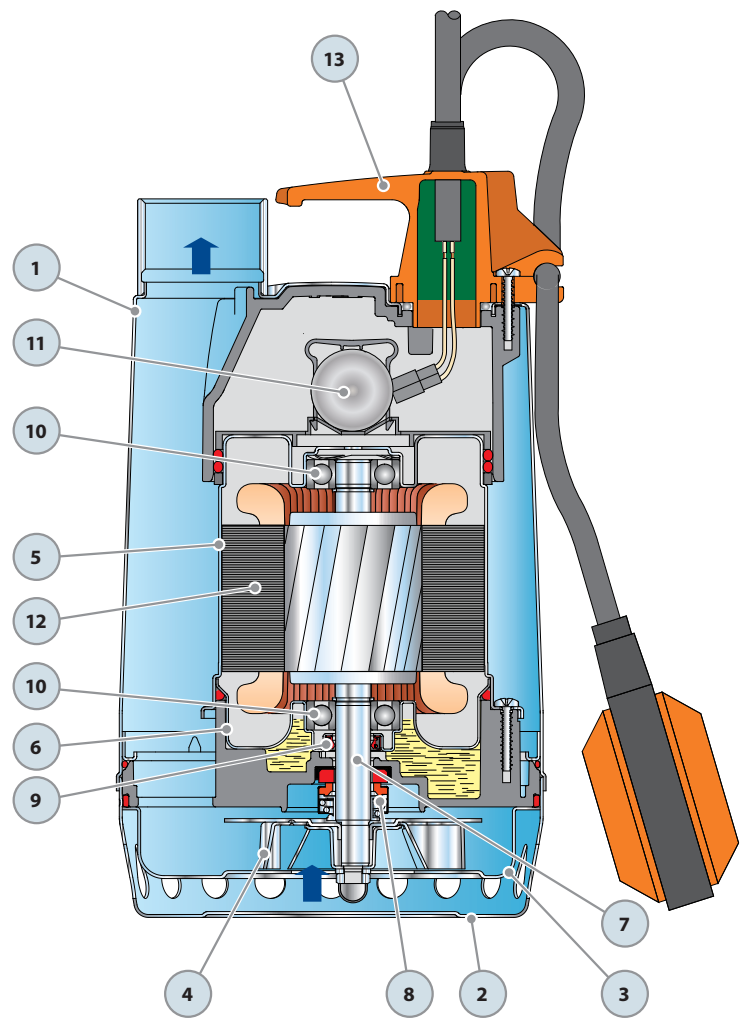

DIMENSIONS AND WEIGHT

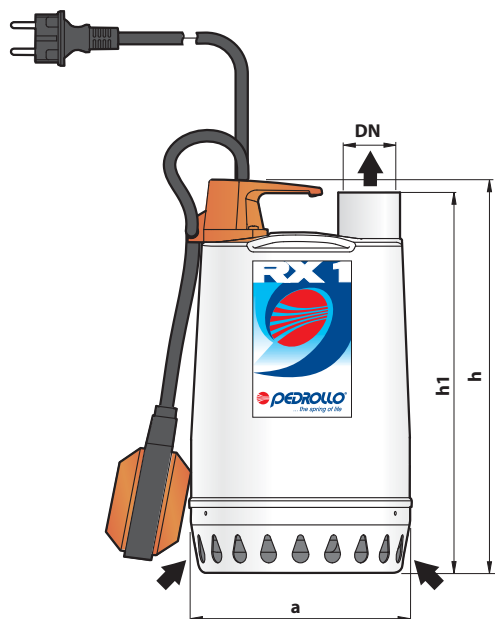

Typical installation

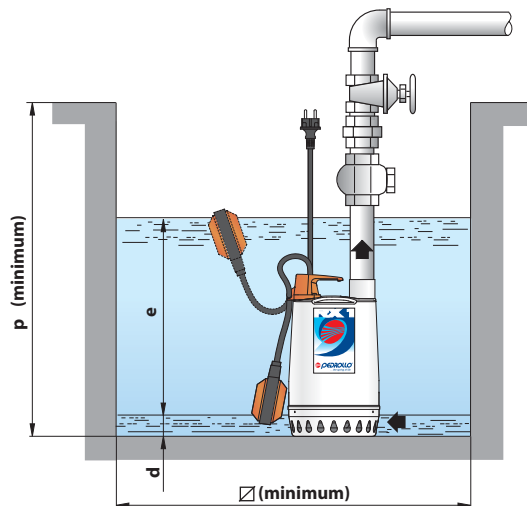

MODEL	PORT DN	DIMENSIONS mm							kg
		a	h	h1	d	e	p	∅	
Single-phase									
RXm 1	1 1/4"	147	255	247	14	variable	350	350	4.7
RXm 2				5.8					
RXm 3			285	277					7.4

ABSORPTION

MODEL	VOLTAGE (single-phase)		
	230 V	240 V	110 V
Single-phase			
RXm 1	1.3 A	1.3 A	3.0 A
RXm 2	2.0 A	2.0 A	5.3 A
RXm 3	3.6 A	3.6 A	7.5 A

PALLETIZATION

MODEL	GROUPAGE			CONTAINER		
	n° pumps	H (mm)	kg	n° pumps	H (mm)	kg
Single-phase						
RXm 1	96	1320	467	162	2131	776
RXm 2	96	1320	573	162	2131	955
RXm 3	96	1360	727	144	1970	1083

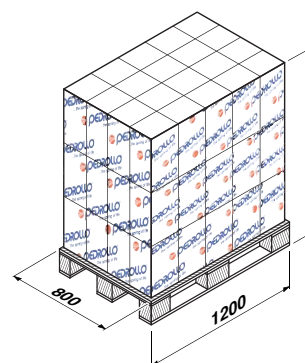

RX 4-5

POS.	COMPONENT	CONSTRUCTION CHARACTERISTICS			
1	PUMP BODY	Stainless steel AISI 304, with threaded port in compliance with ISO 228/1			
2	SUCTION FILTER	Stainless steel AISI 304			
3	SUCTION PLATE	Stainless steel AISI 304			
4	IMPELLER	Stainless steel AISI 304			
5	MOTOR CASING	Stainless steel AISI 304			
6	MOTOR CASING PLATE	Stainless steel AISI 304			
7	MOTOR SHAFT	Stainless steel EN 10088-3 - 1.4104			
8	SHAFT WITH DOUBLE MECHANICAL SEAL SEPARATED BY AN OIL CHAMBER				
	Seal	Shaft	Materials		
	<i>Model</i>	<i>Diameter</i>	<i>Stationary ring</i>	<i>Rotational ring</i>	<i>Elastomer</i>
	MG1-14D SIC	Ø 14 mm	Silicon carbide	Silicon carbide	NBR

9	BEARINGS	6203 ZZ / 6203 ZZ	
10	CAPACITOR		
	Pump	Capacitance	
	<i>Single-phase</i>	<i>(230 V or 240 V)</i>	<i>(110 V)</i>
	RXm 4	20 µF 450 VL	30 µF 250 VL
	RXm 5	25 µF 450 VL	-

11	ELECTRIC MOTOR
	- Single-phase 230 V - 50 Hz with thermal overload protector built-in to the winding
	- Three-phase 400 V - 50 Hz
	- Insulation: F class
	- Protection: IP 68

12	POWER CABLE
	10 metre long "H07 RN-F" cable (with Schuko plug on single-phase versions only)

13	FLOAT SWITCH
	(only for single-phase versions)

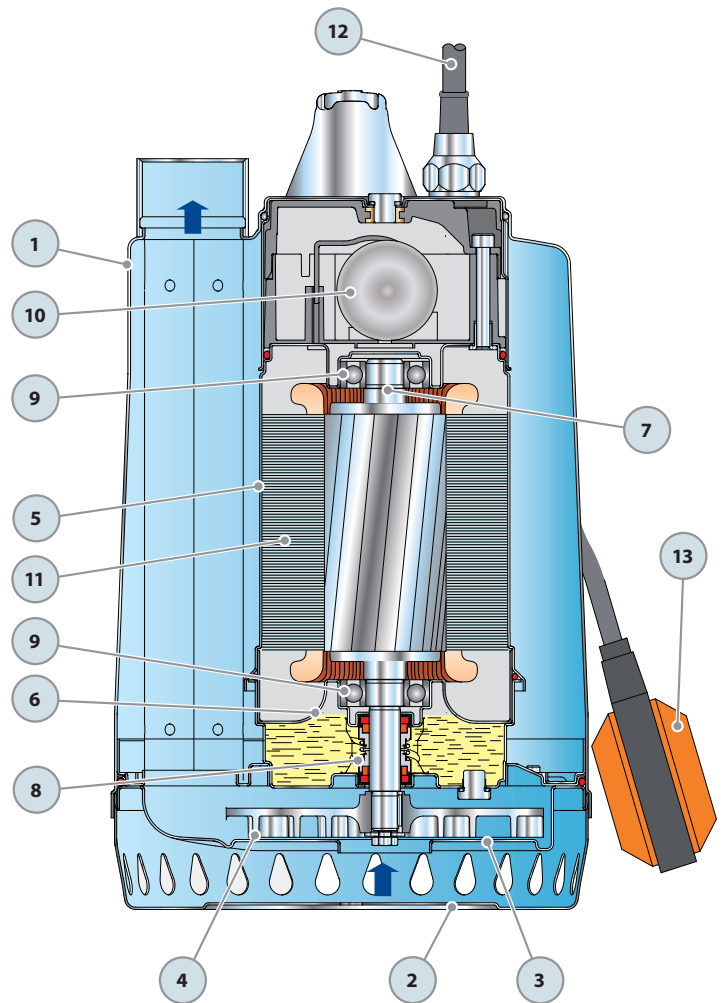

DIMENSIONS AND WEIGHT

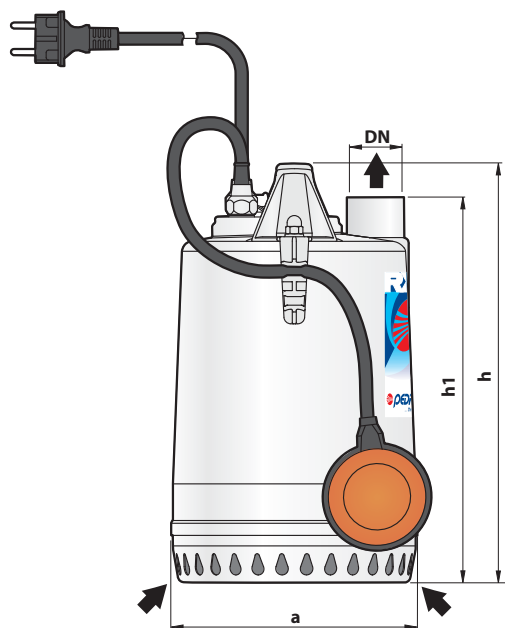

Typical installation

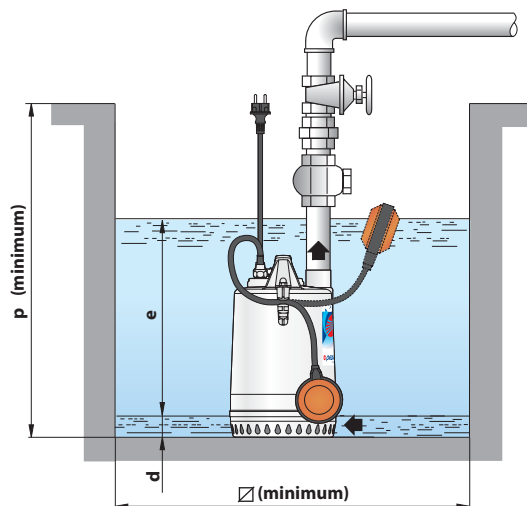

MODEL		PORT DN	DIMENSIONS mm							kg	
Single-phase	Three-phase		a	h	h1	d	e	p	Ø	1~	3~
RXm 4	RX 4	1½"	220	367	336	25	variable	500	500	12.7	11.9
RXm 5	RX 5									13.7	12.7

ABSORPTION

MODEL	VOLTAGE (single-phase)		
	230 V	240 V	110 V
Single-phase	230 V	240 V	110 V
RXm 4	5.4 A	5.4 A	11.0 A
RXm 5	7.5 A	7.5 A	-

MODEL	VOLTAGE (three-phase)			
	230 V	400 V	240 V	415 V
Three-phase	230 V	400 V	240 V	415 V
RX 4	3.6 A	2.1 A	3.6 A	2.1 A
RX 5	6.0 A	3.5 A	6.0 A	3.5 A

PALLETIZATION

MODEL		GROUPAGE			CONTAINER				
Single-phase	Three-phase	n° pumps	H (mm)	kg		n° pumps	H (mm)	kg	
				1~	3~			1~	3~
RXm 4	RX 4	45	1388	589	553	60	1804	779	731
RXm 5	RX 5	45	1388	634	589	60	1804	839	779

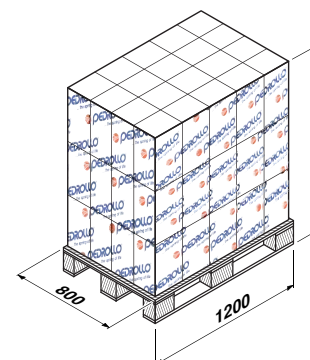

RX 2-3-4-5 "VORTEX"

Submersible pumps

for dirty water



PERFORMANCE RANGE

- Flow rate up to **380 l/min** (22.8 m³/h)
- Head up to **13 m**

APPLICATION LIMITS

- **10 m** maximum immersion depth
- Maximum liquid temperature **+50 °C**
(Maximum liquid temperature +90 °C for a maximum of 3 minutes intermittent service)
- Solids passage:
 - up to **Ø 20 mm** for RX 2/20, RX 3/20
 - up to **Ø 40 mm** for RX 4/40, RX 5/40
- Suction level:
 - **25 mm** above ground level for RX 2/20, RX 3/20
 - **50 mm** above ground level for RX 4/40, RX 5/40
- Continuous service **S1**

CONSTRUCTION AND SAFETY STANDARDS

Complete with:

- **5 m** long power cable for RX 2/20, RX 3/20
- **10 m** long power cable for RX 4/40, RX 5/40
- float switch for single-phase versions

EN 60335-1
IEC 60335-1
CEI 61-150

EN 60034-1
IEC 60034-1
CEI 2-3



CERTIFICATIONS



INSTALLATION AND USE

The **RX-VORTEX** series pumps are suitable for use with **dirty water**. The design solutions that have been adopted, such as the complete cooling of the motor, guarantee the reliability of the pump. They are suitable for use in domestic applications such as for discharging dirty water containing suspended solids.

PATENTS - TRADE MARKS - MODELS

- Registered Community Design n° 342159-0013

OPTIONALS AVAILABLE ON REQUEST

- Special mechanical seal
- Pumps with a **10 m** long power cable
 - ➔ N.B. Standard EN 60335-2-41 states that the power cable must be 10 m long for outdoor applications
- Single-phase pumps without float switch
- Other voltages or 60 Hz frequency

GUARANTEE

1 year subject to terms and conditions

CHARACTERISTIC CURVES AND PERFORMANCE DATA

50 Hz n= 2900 1/min

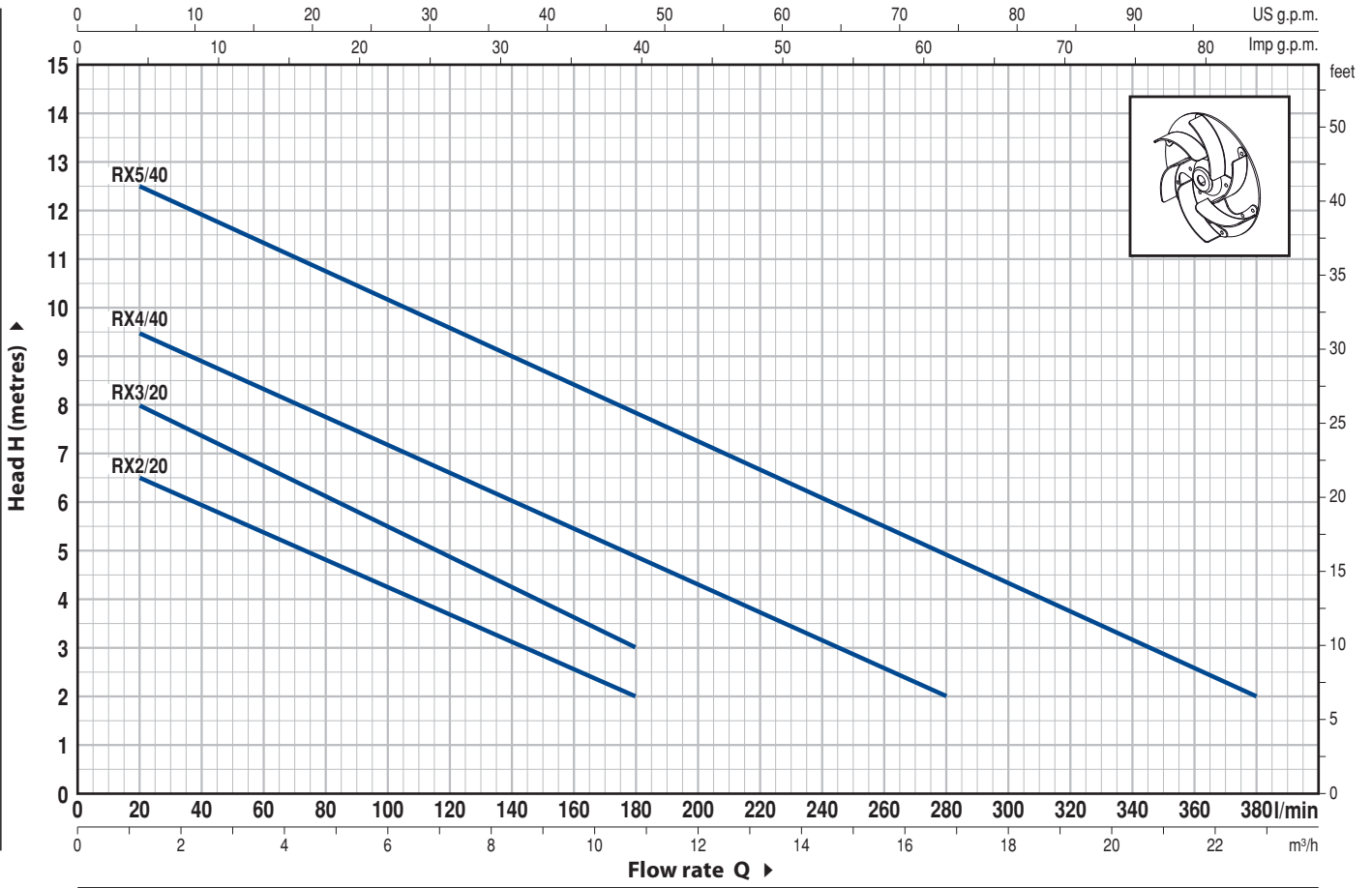

MODEL		POWER		Q	Flow rate (m³/h)																	
Single-phase	Three-phase	kW	HP		0	1.2	2.4	3.6	4.8	6	7.2	8.4	9.6	10.8	13.2	16.8	20.4	22.8				
RXm 2/20	-	0.37	0.50	H metres	0	20	40	60	80	100	120	140	160	180	220	280	340	380				
RXm 3/20	-	0.55	0.75		7	6.5	6	5.4	4.8	4.3	3.7	3.1	2.5	2								
RXm 4/40	RX 4/40	0.75	1		9	8	7.5	6.5	6	5.5	4.7	4.2	3	3								
RXm 5/40	RX 5/40	1.1	1.5		10	9.5	8.7	8.5	7.7	7	6.5	6	5.5	4.7	3.7	2						
					13	12.5	12	11.5	10.7	10	9.5	9	8.3	7.7	6.5	5	3	2				

Q = Flow rate H = Total manometric head

Tolerance of characteristic curves in compliance with EN ISO 9906 App. A.

RX 2-3 "VORTEX"

POS.	COMPONENT	CONSTRUCTION CHARACTERISTICS			
1	PUMP BODY	Stainless steel AISI 304, with threaded port in compliance with ISO 228/1			
2	SUCTION FILTER	Stainless steel AISI 304			
3	SUCTION PLATE	Stainless steel AISI 304			
4	DIFFUSER	Technopolymer			
5	IMPELLER	Stainless steel AISI 304 VORTEX type			
6	MOTOR CASING	Stainless steel AISI 304			
7	MOTOR CASING PLATE	Stainless steel AISI 304			
8	MOTOR SHAFT	Stainless steel EN 10088-3 - 1.4104			
9	SHAFT WITH DOUBLE SEAL AND OIL CHAMBER				
	<i>Seal</i>	<i>Shaft</i>	<i>Materials</i>		
	<i>Model</i>	<i>Diameter</i>	<i>Stationary ring</i>	<i>Rotational ring</i>	<i>Elastomer</i>
	AR-12R SIC	Ø 12 mm	Ceramic	Silicon carbide	NBR
10	LIP SEAL	Ø 12 x Ø 19 x H 5 mm			
11	BEARINGS	6201 ZZ / 6201 ZZ			
12	CAPACITOR				
	<i>Pump</i>	<i>Capacitance</i>			
	<i>Single-phase</i>	<i>(230 V or 240 V)</i>	<i>(110 V)</i>		
	RXm 2/20	10 µF 450 VL	16 µF 250 VL		
	RXm 3/20	14 µF 450 VL	16 µF 250 VL		

13	ELECTRIC MOTOR
	– Single-phase 230 V - 50 Hz with thermal overload protector built-in to the winding
	– Insulation: F class.
	– Protection: IP 68.

14	HANDLE ASSEMBLY (resin sealed)
	Complete with:
	– 5 metre long "H07 RN-F" power cable with Schuko plug
	– Float switch.

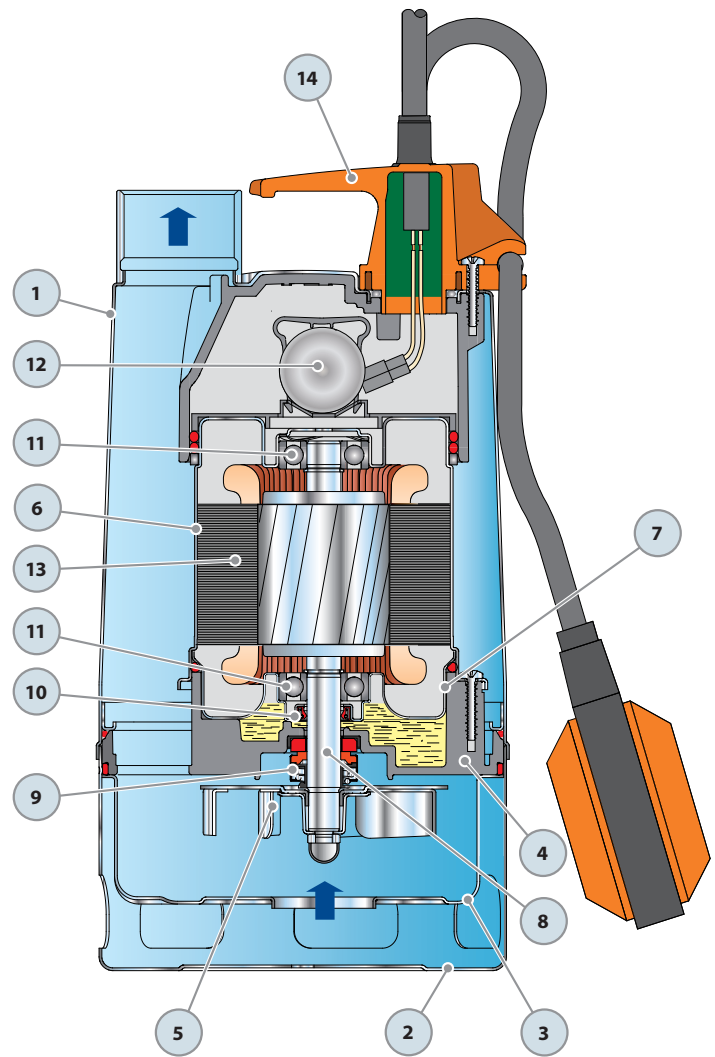

DIMENSIONS AND WEIGHT

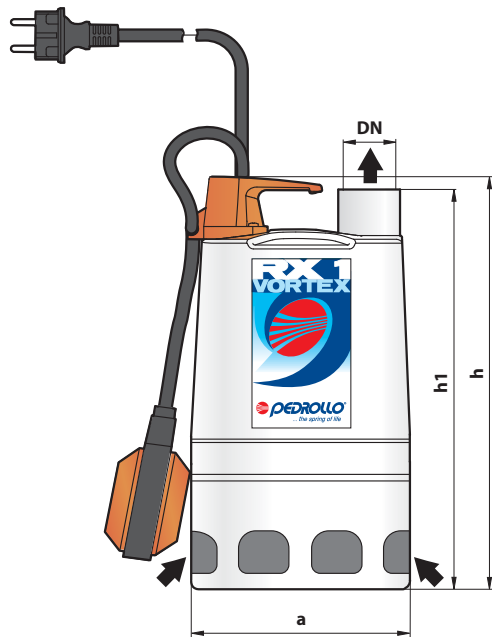

Typical installation

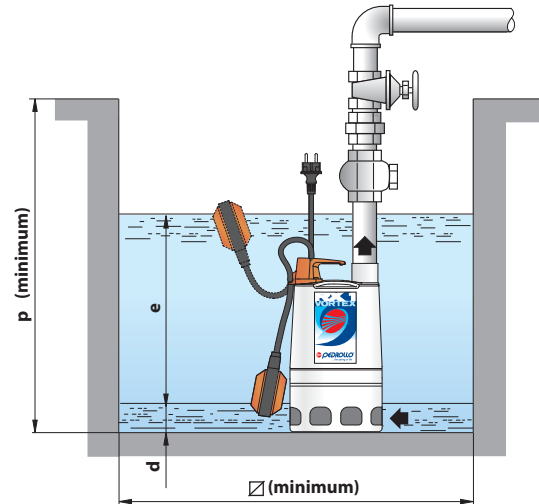

MODEL	PORT	DIMENSIONS mm							kg
		a	h	h1	d	e	p	∅	
Single-phase	DN								
RXm 2/20	1 1/4"	147	290	278	25	variable	350	350	6.1
RXm 3/20			320	308					7.85

ABSORPTION

MODEL	VOLTAGE (single-phase)		
	230 V	240 V	110 V
Single-phase			
RXm 2/20	2.6 A	2.6 A	6.5 A
RXm 3/20	3.2 A	3.2 A	7.5 A

PALLETIZATION

MODEL	GROUPAGE			CONTAINER		
	n° pumps	H (mm)	kg	n° pumps	H (mm)	kg
Single-phase						
RXm 2/20	96	1500	607	144	2180	902
RXm 3/20	60	1310	488	100	2090	802

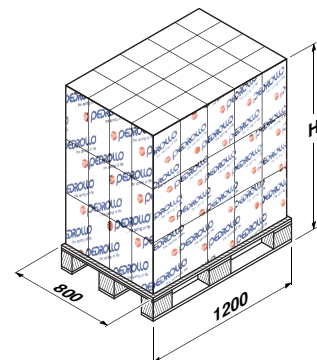

RX 4-5 "VORTEX"

POS.	COMPONENT	CONSTRUCTION CHARACTERISTICS			
1	PUMP BODY	Stainless steel AISI 304, with threaded port in compliance with ISO 228/1			
2	SUCTION FILTER	Stainless steel AISI 304			
3	SUCTION PLATE	Stainless steel AISI 304			
4	IMPELLER	Stainless steel AISI 304 VORTEX type			
5	MOTOR CASING	Stainless steel AISI 304			
6	MOTOR CASING PLATE	Stainless steel AISI 304			
7	MOTOR SHAFT	Stainless steel EN 10088-3 - 1.4104			
8	SHAFT WITH DOUBLE MECHANICAL SEAL SEPARATED BY AN OIL CHAMBER				
	<i>Seal</i>	<i>Shaft</i>	<i>Materials</i>		
	<i>Model</i>	<i>Diameter</i>	<i>Stationary ring</i>	<i>Rotational ring</i>	<i>Elastomer</i>
	MG1-14D SIC	Ø 14 mm	Silicon carbide	Silicon carbide	NBR
9	BEARINGS	6203 ZZ / 6203 ZZ			
10	CAPACITOR				
	<i>Pump</i>	<i>Capacitance</i>			
	<i>Single-phase</i>	(230 V or 240 V)	(110 V)		
	RXm 4/40	20 µF 450 VL	30 µF	250 VL	
	RXm 5/40	25 µF 450 VL	-		
11	ELECTRIC MOTOR				
	<ul style="list-style-type: none"> - Single-phase 230 V - 50 Hz with thermal overload protector built-in to the winding - Three-phase 400 V - 50 Hz - Insulation: F class - Protection: IP 68 				
12	POWER CABLE				
	10 metre long "H07 RN-F" cable (with Schuko plug on single-phase versions only)				
13	FLOAT SWITCH (only for single-phase versions)				

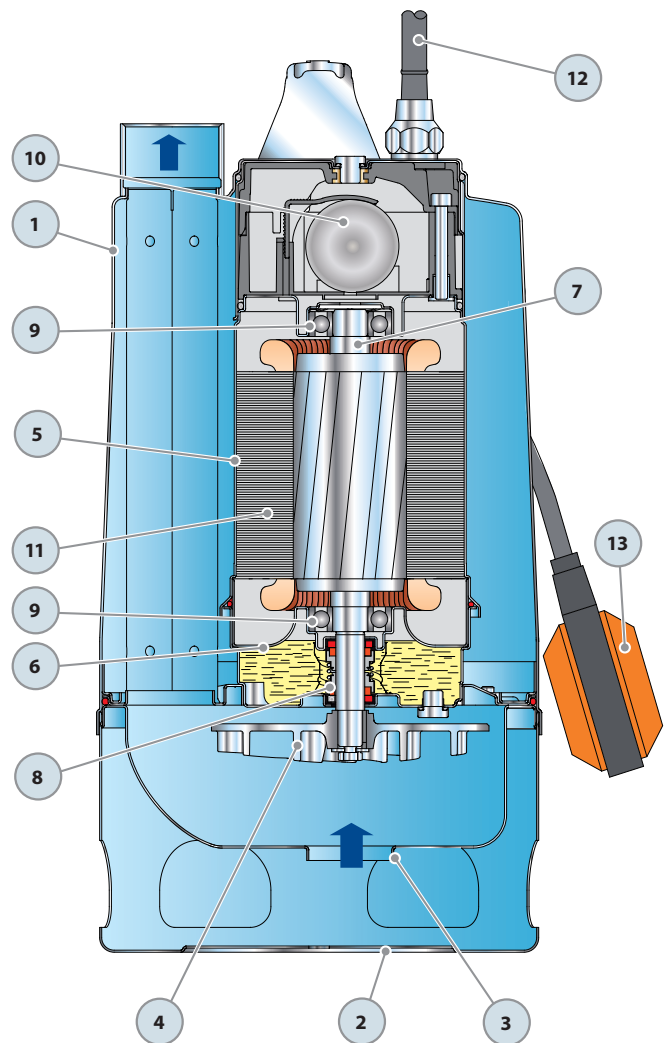

DIMENSIONS AND WEIGHT

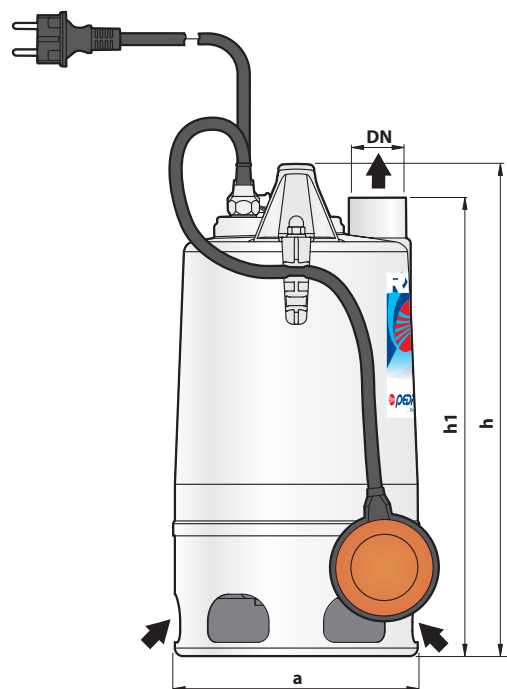

Typical installation

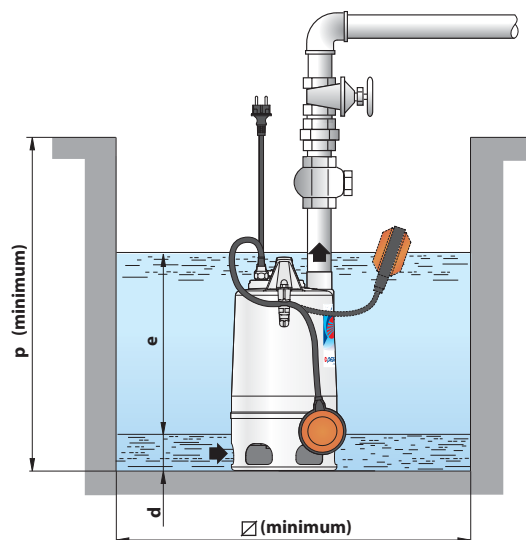

MODEL		PORT	DIMENSIONS mm							kg	
Single-phase	Three-phase	DN	a	h	h1	d	e	p	Ø	1~	3~
RXm 4/40	RX 4/40	1½"	220	430	400	50	variable	500	500	13.0	12.2
RXm 5/40	RX 5/40									14.0	13.0

ABSORPTION

MODEL	VOLTAGE (single-phase)		
	230 V	240 V	110 V
Single-phase	230 V	240 V	110 V
RXm 4/40	5.2 A	5.2 A	10.5 A
RXm 5/40	6.5 A	6.5 A	-

MODEL	VOLTAGE (three-phase)			
	230 V	400 V	240 V	415 V
Three-phase	230 V	400 V	240 V	415 V
RX 4/40	3.6 A	2.1 A	3.6 A	2.1A
RX 5/40	5.4 A	3.1 A	5.4 A	3.1 A

PALLETIZATION

MODEL		GROUPAGE				CONTAINER			
Single-phase	Three-phase	n° pumps	H (mm)	kg		n° pumps	H (mm)	kg	
				1~	3~			1~	3~
RXm 4/40	RX 4/40	45	1574	602	566	60	2052	797	749
RXm 5/40	RX 5/40	45	1574	647	602	60	2052	857	797

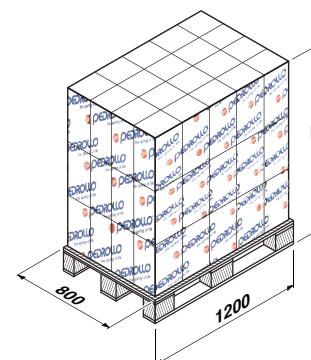

VX-I "VORTEX"

Submersible pumps

for sewage water



PERFORMANCE RANGE

- Flow rate up to **400 l/min** (24 m³/h)
- Head up to **10 m**

APPLICATION LIMITS

- **5 m** maximum immersion depth
- Maximum liquid temperature **+40 °C**
- Solids passage:
 - up to **Ø 40 mm** for VX8/35I - VX10/35I
 - up to **Ø 50 mm** for VX8/50I - VX10/50I
- Minimum immersion depth for continuous service:
 - **270 mm** for VX8/35I - VX10/35I
 - **300 mm** for VX8/50I - VX10/50I

CONSTRUCTION AND SAFETY STANDARDS

- Complete with **5 m** long power cable
- Float switch for single-phase versions

EN 60335-1
IEC 60335-1
CEI 61-150

EN 60034-1
IEC 60034-1
CEI 2-3



CERTIFICATIONS



INSTALLATION AND USE

Suitable for use with **sewage water** in domestic, civil and industrial applications or in any other situation, such as with water mixed with mud, with groundwater and with surface water, where the water contains suspended solids. They are suitable for use in applications such as for draining flooded areas such as cellars, underground car parks, car washes, for emptying cesspools and for sewage disposal. These pumps distinguish themselves for their reliability, which can be best appreciated under automatic operating conditions in fixed installations.

PATENTS - TRADE MARKS - MODELS

- Patent pending n° BO2008A000494, BO2008A000496

OPTIONALS AVAILABLE ON REQUEST

- Pumps with a **10 m** long power cable
 - ➔ N.B. Standard EN 60335-2-41 states that the power cable must be 10 m long for outdoor applications
- Single-phase pumps without float switch
- Other voltages or 60 Hz frequency

GUARANTEE

1 year subject to terms and conditions

CHARACTERISTIC CURVES AND PERFORMANCE DATA

50 Hz n= 2900 1/min

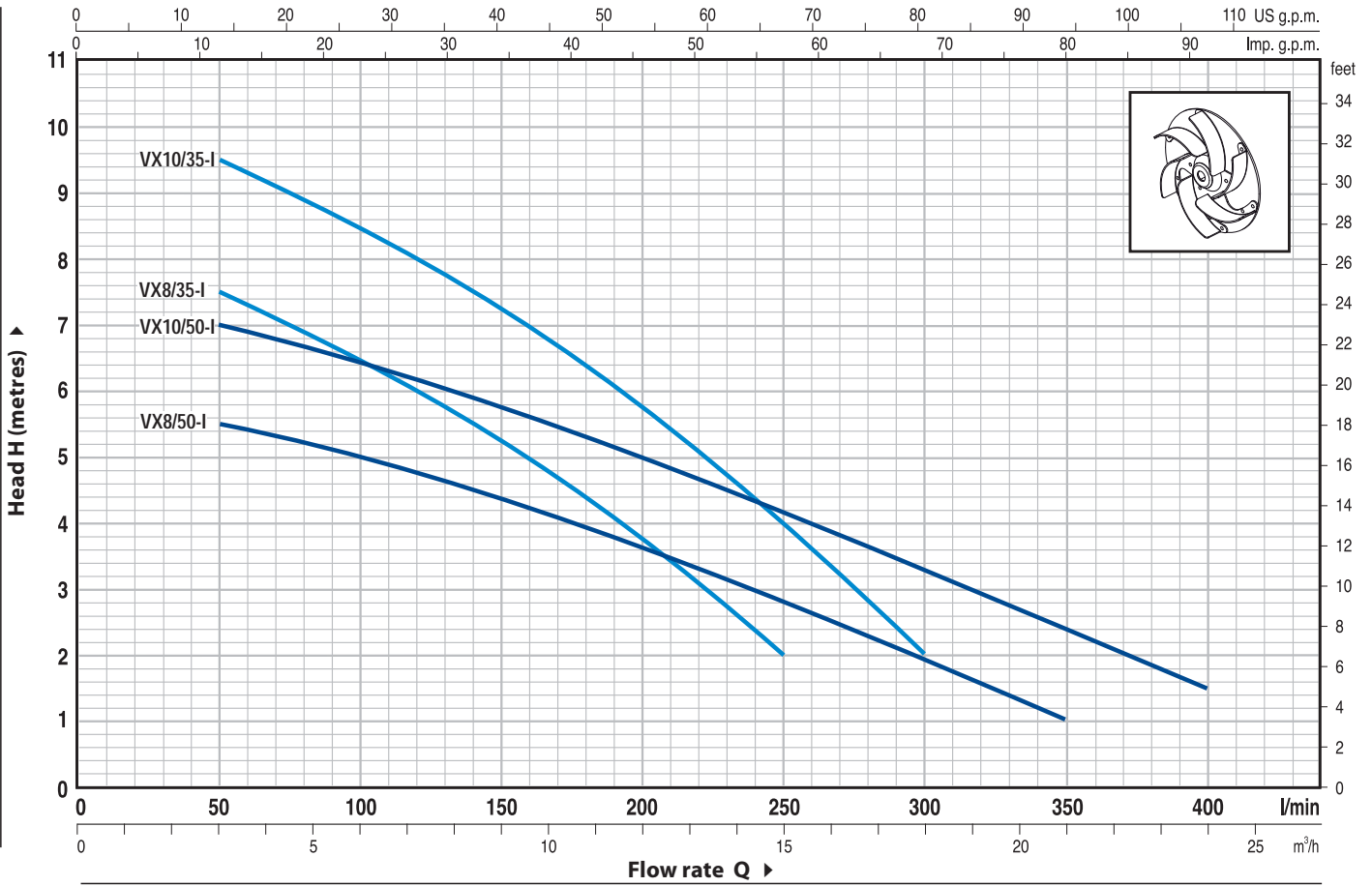

MODEL		POWER		Q	H metres											
Single-phase	Three-phase	kW	HP		0	3	6	9	12	15	18	21	24			
VXm 8/35-I	-	0.55	0.75	0	8.4	7.5	6.5	5.2	3.7	2						
VXm 10/35-I	VX 10/35-I	0.75	1	3	10	9.5	8.5	7.2	5.8	4	2					
VXm 8/50-I	-	0.55	0.75	6	6	5.5	5	4.4	3.6	2.8	2	1				
VXm 10/50-I	VX 10/50-I	0.75	1	9	7.5	7	6.5	5.8	5	4	3.2	2.4	1.5			

Q = Flow rate H = Total manometric head

Tolerance of characteristic curves in compliance with EN ISO 9906 App. A.

VX-I "VORTEX"

POS.	COMPONENT	CONSTRUCTION CHARACTERISTICS			
1	PUMP BODY	Stainless steel AISI 304, with threaded port in compliance with ISO 228/1			
2	BASE	Stainless steel AISI 304			
3	IMPELLER	Stainless steel AISI 304 VORTEX type			
4	MOTOR CASING	Stainless steel AISI 304			
5	MOTOR CASING PLATE	Stainless steel AISI 304			
6	MOTOR SHAFT	Stainless steel AISI 431			
7	SHAFT WITH DOUBLE SEAL AND OIL CHAMBER				
	<i>Seal</i>	<i>Shaft</i>	<i>Materials</i>		
	<i>Model</i>	<i>Diameter</i>	<i>Stationary ring</i>	<i>Rotational ring</i>	<i>Elastomer</i>
	MG1-14 SIC	Ø 14 mm	Ceramic	Silicon carbide	NBR
8	LIP SEAL	Ø 15 x Ø 24 x H 5 mm			
9	BEARINGS	6203 ZZ / 6203 ZZ			
10	CAPACITOR				
	<i>Pump</i>	<i>Capacitance</i>			
	<i>Single-phase</i>	<i>(230 V or 240 V)</i>	<i>(110 V)</i>		
	VXm 8/35-I				
	VXm 8/50-I	20 µF 450 VL	30 µF 250 VL		
	VXm 10/35-I				
	VXm 10/50-I				
11	ELECTRIC MOTOR				
	<ul style="list-style-type: none"> - Single-phase 230 V - 50 Hz with thermal overload protector built-in to the winding - Three-phase 400 V - 50 Hz - Insulation: F class - Protection: IP 68 				
12	POWER CABLE				
	5 metre long "H07 RN-F" cable (with Schuko plug on single-phase versions only)				
13	FLOAT SWITCH				
	(only for single-phase versions)				

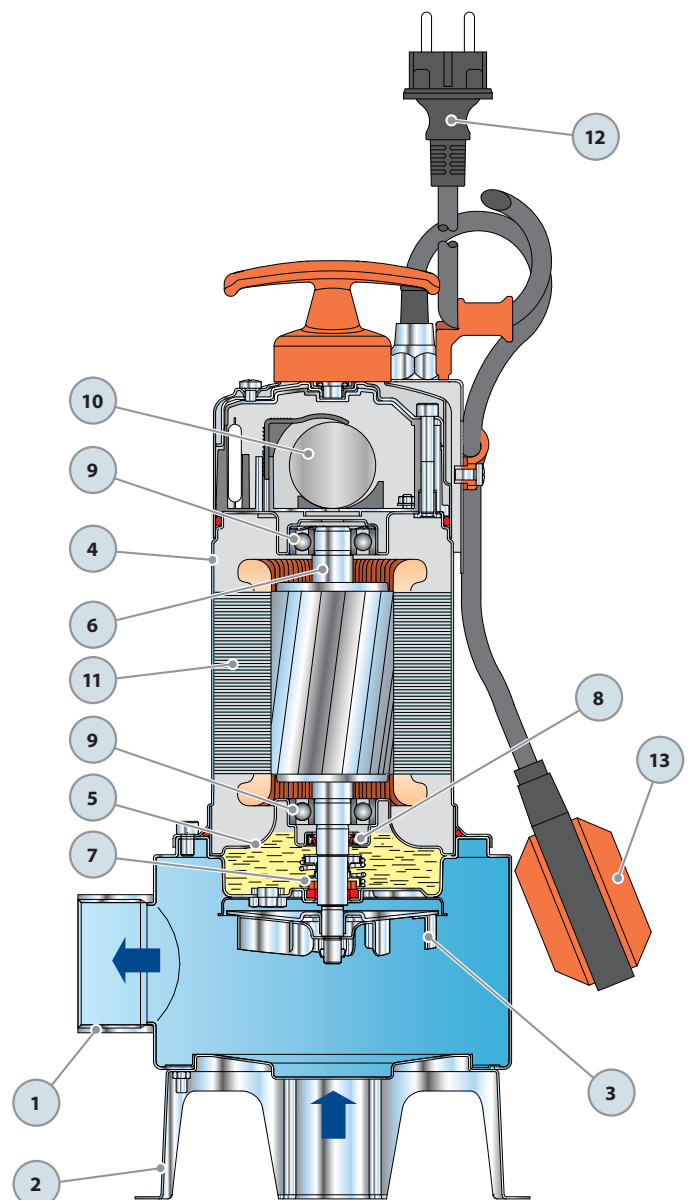

DIMENSIONS AND WEIGHT

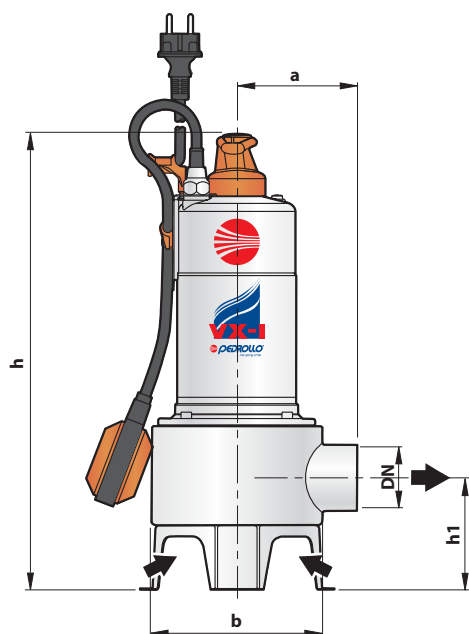

Typical installation

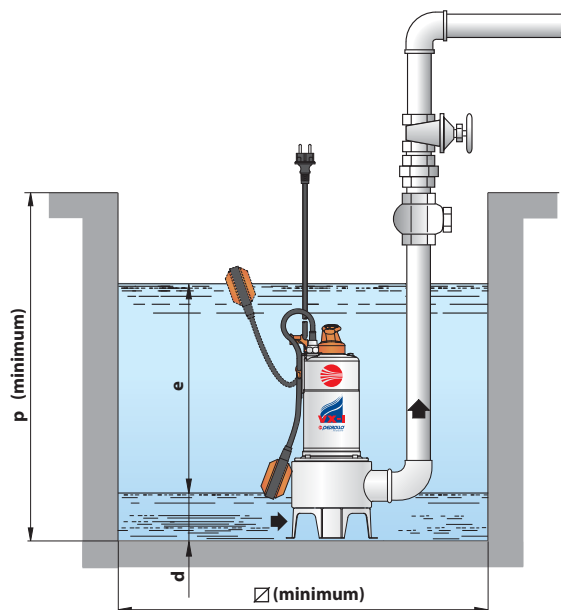

MODEL		PORT DN	solids passage	DIMENSIONS mm								kg	
Single-phase	Three-phase			a	b	h	h1	d	e	p	Ø	1~	3~
VXm 8/35-I	-	1½"	Ø 40 mm	108	166	404	87	50	variable	500	500	9.5	-
VXm 10/35-I	VX 10/35-I											10.8	9.3
VXm 8/50-I	-	2"	Ø 50 mm	118	-	434	108	60	-	-	-	9.4	-
VXm 10/50-I	VX 10/50-I											10.6	9.2

ABSORPTION

MODEL	VOLTAGE (single-phase)		
	230 V	240 V	110 V
Single-phase	230 V	240 V	110 V
VXm 8/35-I	3.3 A	3.3 A	7.6 A
VXm 10/35-I	5.0 A	5.0 A	11.5 A
VXm 8/50-I	3.5 A	3.5 A	8.0 A
VXm 10/50-I	5.0 A	5.0 A	11.5 A

MODEL	VOLTAGE (three-phase)			
	230 V	400 V	240 V	415 V
Three-phase	230 V	400 V	240 V	415 V
VX 10/35-I	3.6 A	2.1 A	3.6 A	2.1 A
VX 10/50-I	3.6 A	2.1 A	3.6 A	2.1 A

PALLETIZATION

MODEL		GROUPAGE			CONTAINER				
Single-phase	Three-phase	n° pumps	H (mm)	kg		n° pumps	H (mm)	kg	
				1~	3~			1~	3~
VXm 8/35-I	-	60	1520	588	-	80	1980	778	-
VXm 10/35-I	VX 10/35-I	60	1520	662	576	80	1980	877	762
VXm 8/50-I	-	60	1520	579	-	80	1980	766	-
VXm 10/50-I	VX 10/50-I	60	1520	652	569	80	1980	864	753

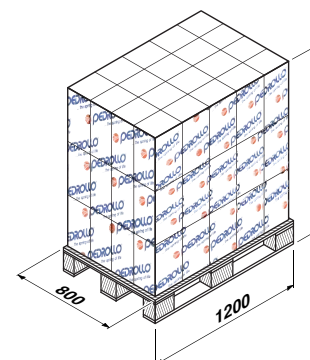

MC-I "DOUBLE-CHANNEL"

Submersible pumps

for sewage water



PERFORMANCE RANGE

- Flow rate up to **800 l/min** (48 m³/h)
- Head up to **15 m**

APPLICATION LIMITS

- **5 m** maximum immersion depth
- Maximum liquid temperature **+40 °C**
- Passage of suspended solids up to **Ø 50 mm**
- **300 mm** minimum immersion depth for continuous service

CONSTRUCTION AND SAFETY STANDARDS

- Complete with **5 m** long power cable
- Float switch for single-phase versions

EN 60335-1
IEC 60335-1
CEI 61-150

EN 60034-1
IEC 60034-1
CEI 2-3



CERTIFICATIONS



AN30



YxpTECT-003

INSTALLATION AND USE

MC-I submersible pumps are suitable for draining **dirty water and sewage** in domestic and civil applications. They come equipped with a **DOUBLE-CHANNEL** impeller and are capable of pumping liquids containing short fibred suspended solids up to Ø 50 mm. They are ideal for pumping sewage water, waste water, surface water and water mixed with mud in locations such as holiday homes and detached homes.

These pumps distinguish themselves for their reliability, which can be best appreciated under automatic operating conditions in fixed installations.

PATENTS - TRADE MARKS - MODELS

- Patent pending n° BO2008A000494, BO2008A000496

OPTIONALS AVAILABLE ON REQUEST

- Pumps with a **10 m** long power cable
 - ➔ N.B. Standard EN 60335-2-41 states that the power cable must be 10 m long for outdoor applications
- Single-phase pumps without float switch
- Other voltages or 60 Hz frequency

GUARANTEE

1 year subject to terms and conditions

CHARACTERISTIC CURVES AND PERFORMANCE DATA

50 Hz n= 2900 1/min

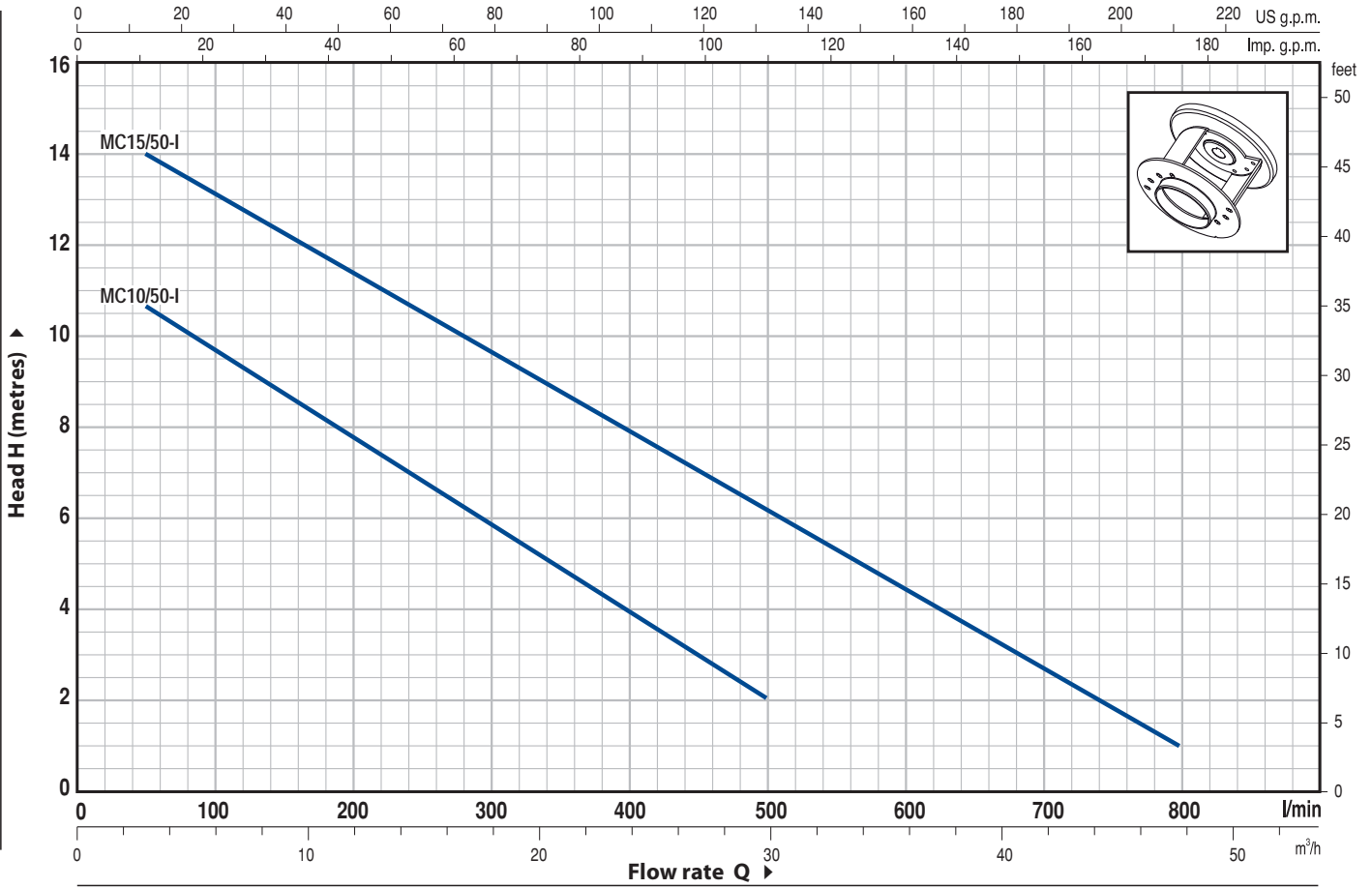

MODEL		POWER		Q	Flow rate															
Single-phase	Three-phase	kW	HP		m³/h	0	3	6	9	12	15	18	21	24	27	30	36	42	48	
MCm 10/50-I	MC 10/50-I	0.75	1	l/min	0	50	100	150	200	250	300	350	400	450	500	600	700	800		
-	MC 15/50-I	1.1	1.5	H metres	12	10.7	9.7	8.7	7.8	6.8	5.9	5	4	3	2					
					15	14	13	12.3	11.5	10.5	9.7	8.8	8	7	6.2	4.5	2.7	1		

Q = Flow rate H = Total manometric head

Tolerance of characteristic curves in compliance with EN ISO 9906 App. A.

MC-I "DOUBLE-CHANNEL"

POS.	COMPONENT	CONSTRUCTION CHARACTERISTICS			
1	PUMP BODY	Stainless steel AISI 304, with threaded port in compliance with ISO 228/1			
2	BASE	Stainless steel AISI 304			
3	IMPELLER	Stainless steel AISI 304 DOUBLE-CHANNEL type			
4	MOTOR CASING	Stainless steel AISI 304			
5	MOTOR CASING PLATE	Stainless steel AISI 304			
6	MOTOR SHAFT	Stainless steel AISI 431			
7	SHAFT WITH DOUBLE SEAL AND OIL CHAMBER				
	<i>Seal</i>	<i>Shaft</i>	<i>Materials</i>		
	<i>Model</i>	<i>Diameter</i>	<i>Stationary ring</i>	<i>Rotational ring</i>	<i>Elastomer</i>
	MG1-14 SIC	Ø 14 mm	Ceramic	Silicon carbide	NBR
8	LIP SEAL	Ø 15 x Ø 24 x H 5 mm			
9	BEARINGS	6203 ZZ / 6203 ZZ			
10	CAPACITOR				
	<i>Capacitance</i>				
	<i>(230 V or 240 V)</i>	<i>(110 V)</i>			
	20 µF 450 VL	30 µF 250 VL			
11	ELECTRIC MOTOR				
	<ul style="list-style-type: none"> - Single-phase 230 V - 50 Hz with thermal overload protector built-in to the winding - Three-phase 400 V - 50 Hz - Insulation: F class - Protection: IP 68 				
12	POWER CABLE				
	5 metre long "H07 RN-F" cable (with Schuko plug on single-phase versions only)				
13	FLOAT SWITCH	(only for single-phase versions)			

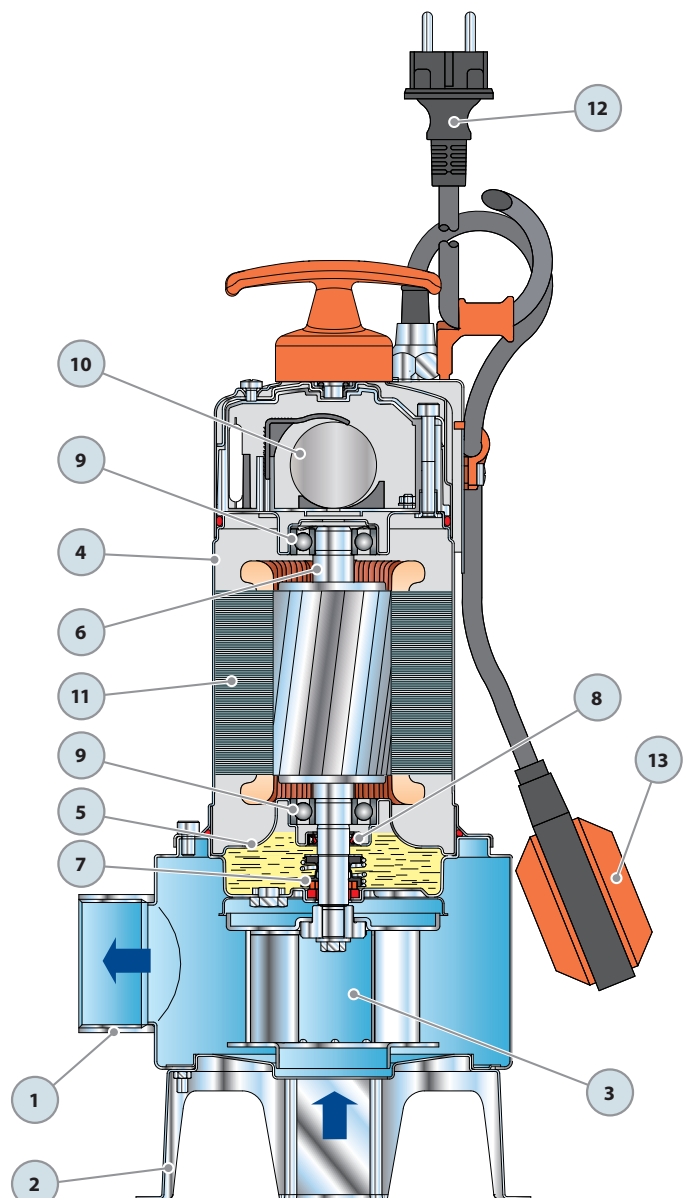

DIMENSIONS AND WEIGHT

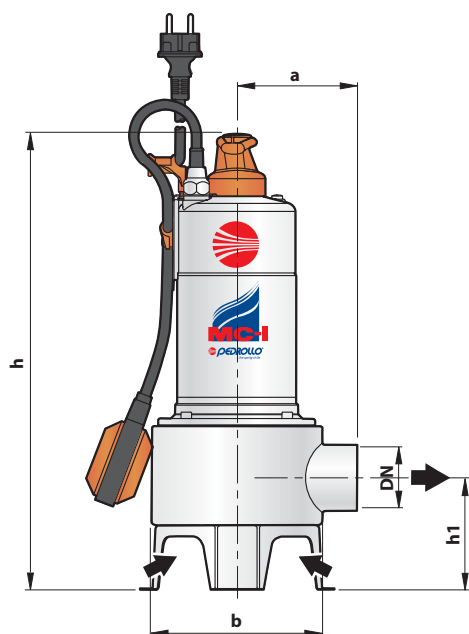

Typical installation

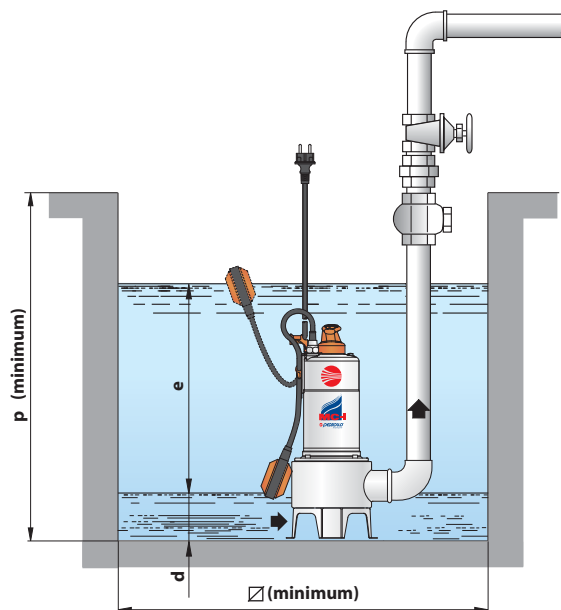

MODEL		PORT DN	solids passage	DIMENSIONS mm								kg	
Single-phase	Three-phase			a	b	h	h1	d	e	p	□	1~	3~
MCm 10/50-I	MC 10/50-I	2"	Ø 50 mm	118	166	434	108	60	variable	500	500	10.9	9.5
-	MC 15/50-I											-	10.5

ABSORPTION

MODEL	VOLTAGE (single-phase)		
	230 V	240 V	110 V
MCm 10/50-I	5.0 A	5.0 A	11.5 A

MODEL	VOLTAGE (three-phase)			
	230 V	400 V	240 V	415 V
MC 10/50-I	3.6 A	2.1 A	3.6 A	2.1 A
MC 15/50-I	6.1 A	3.5 A	6.1 A	3.5 A

PALLETIZATION

MODEL		GROUPAGE				CONTAINER			
Single-phase	Three-phase	n° pumps	H (mm)	kg		n° pumps	H (mm)	kg	
				1~	3~			1~	3~
MCm 10/50-I	MC 10/50-I	60	1520	671	588	80	1980	889	778
-	MC 15/50-I	60	1520	-	645	80	1980	-	854

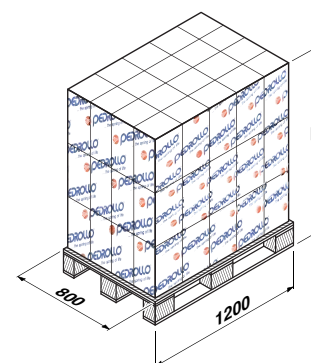

Submersible drainage pumps

for clear water



PERFORMANCE RANGE

- Flow rate up to **300 l/min** (18 m³/h)
- Head up to **14 m**

APPLICATION LIMITS

- **5 m** maximum immersion depth
- Maximum liquid temperature **+40 °C**
- Passage of suspended solids up to **Ø 10 mm**
- Suction down to **21 mm** above ground level
- **180 mm** minimum immersion depth for continuous service

CONSTRUCTION AND SAFETY STANDARDS

- Complete with **5 m** long power cable

EN 60335-1
IEC 60335-1
CEI 61-150

EN 60034-1
IEC 60034-1
CEI 2-3



CERTIFICATIONS



INSTALLATION AND USE

Designed to pump **clear or slightly dirty water**, these pumps are suitable for use in domestic applications and in particular for draining flooded areas such as cellars or for emptying tanks and reservoirs; they distinguish themselves for the ease with which they are installed and their reliability under automatic operating conditions in fixed installations.

OPTIONALS AVAILABLE ON REQUEST

- Special mechanical seal.
- Pumps with a **10 m** long power cable
 - ➔ N.B. Standard EN 60335-2-41 states that the power cable must be 10 m long for outdoor applications
- Single-phase pumps without float switch
- Other voltages or 60 Hz frequency

GUARANTEE

1 year subject to terms and conditions

CHARACTERISTIC CURVES AND PERFORMANCE DATA

50 Hz n= 2900 1/min

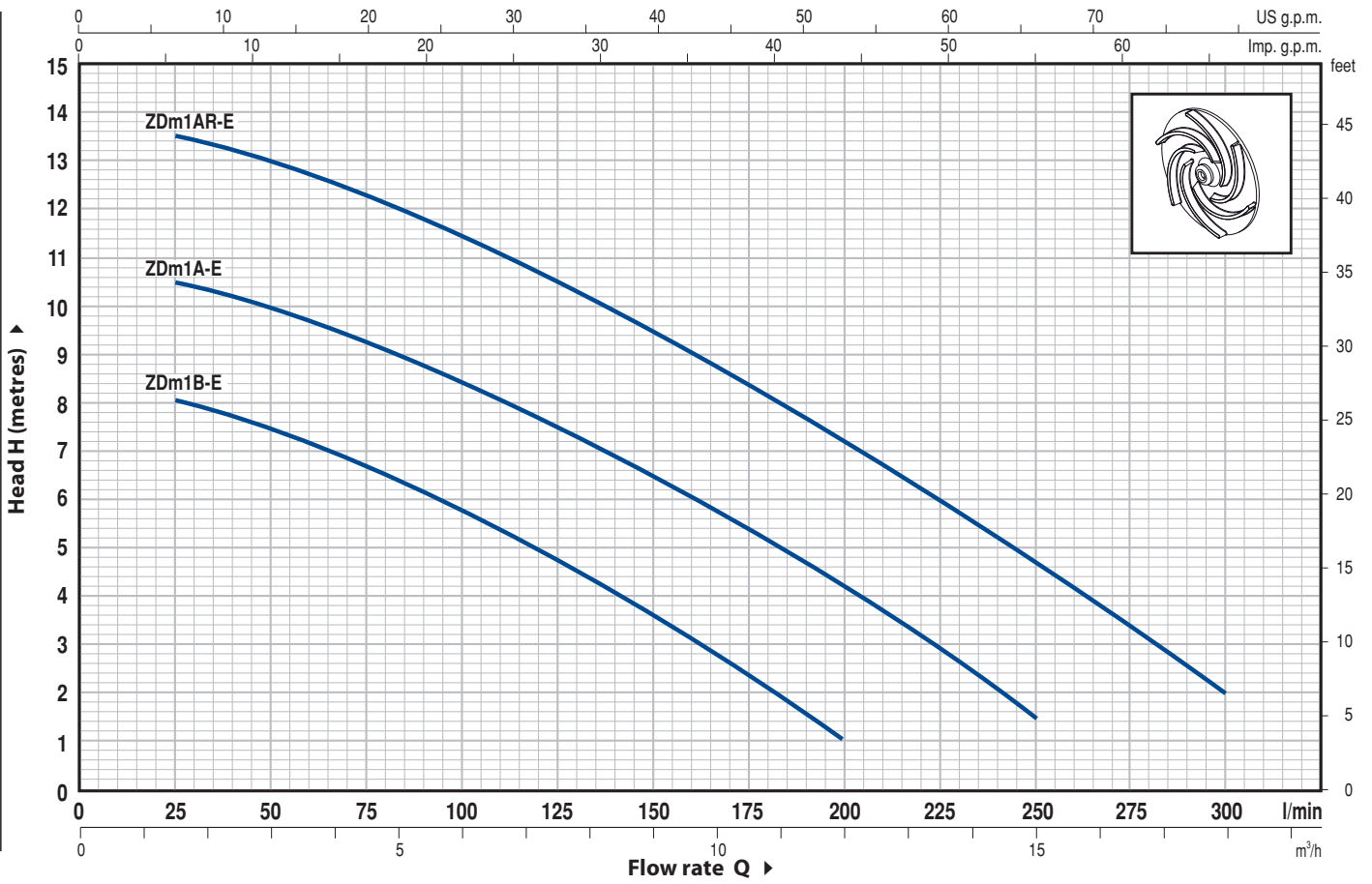

MODEL	POWER		Q	0	1.5	3.0	4.5	6.0	7.5	9.0	10.5	12.0	13.5	15.0	16.5	18.0
	kW	HP		0	25	50	75	100	125	150	175	200	225	250	275	300
Single-phase																
ZDm 1B-E	0.37	0.50	H metres	8.5	8	7.5	6.5	5.5	4.8	3.5	2.5	1				
ZDm 1A-E	0.50	0.70		11	10.5	10	9	8.5	7.5	6.5	5.5	4	2.5	1.5		
ZDm 1AR-E	0.60	0.85		14	13.5	13	12.2	11.5	10.5	9.5	8.3	7	5.7	4.5	3.2	2

Q = Flow rate H = Total manometric head

Tolerance of characteristic curves in compliance with EN ISO 9906 App. A.

POS.	COMPONENT	CONSTRUCTION CHARACTERISTICS			
1	PUMP BODY	Cast iron, with threaded port in compliance with ISO 228/1			
2	SUCTION FILTER	Stainless steel AISI 304			
3	SUCTION PLATE	Stainless steel AISI 304			
4	IMPELLER	Noryl GFN2V open type			
5	MOTOR SLEEVE	Stainless steel AISI 304			
6	MOTOR CASING	Steel			
7	MOTOR SHAFT	Stainless steel EN 10088-3 - 1.4104			
8	SHAFT WITH DOUBLE SEAL				
	Seal	Shaft			
	<i>Model</i>	<i>Diameter</i>	<i>Stationary ring</i>	<i>Rotational ring</i>	<i>Elastomer</i>
	AR-12R	Ø 12 mm	Ceramic	Graphite	NBR
9	LIP SEAL	Ø 12 x Ø 22 x H 6 mm			

10	BEARINGS	6201 ZZ / 6201 ZZ	
11	CAPACITOR		
	Pump	Capacitance	
	<i>Single-phase</i>	<i>(230 V or 240 V)</i>	<i>(110 V)</i>
	ZDm 1B-E	10 µF 450 VL	16 µF 250 VL
	ZDm 1A-E	12.5 µF 450 VL	30 µF 250 VL
	ZDm 1AR-E	16 µF 450 VL	30 µF 250 VL

12	ELECTRIC MOTOR
	– Single-phase 230 V - 50 Hz with thermal overload protector built-in to the winding.
	– Insulation: F class.
	– Protection: IP 68.

13	POWER CABLE
	5 metre long "H07 RN-F" cable with Schuko plug

14	FLOAT SWITCH
	(only for single-phase versions)

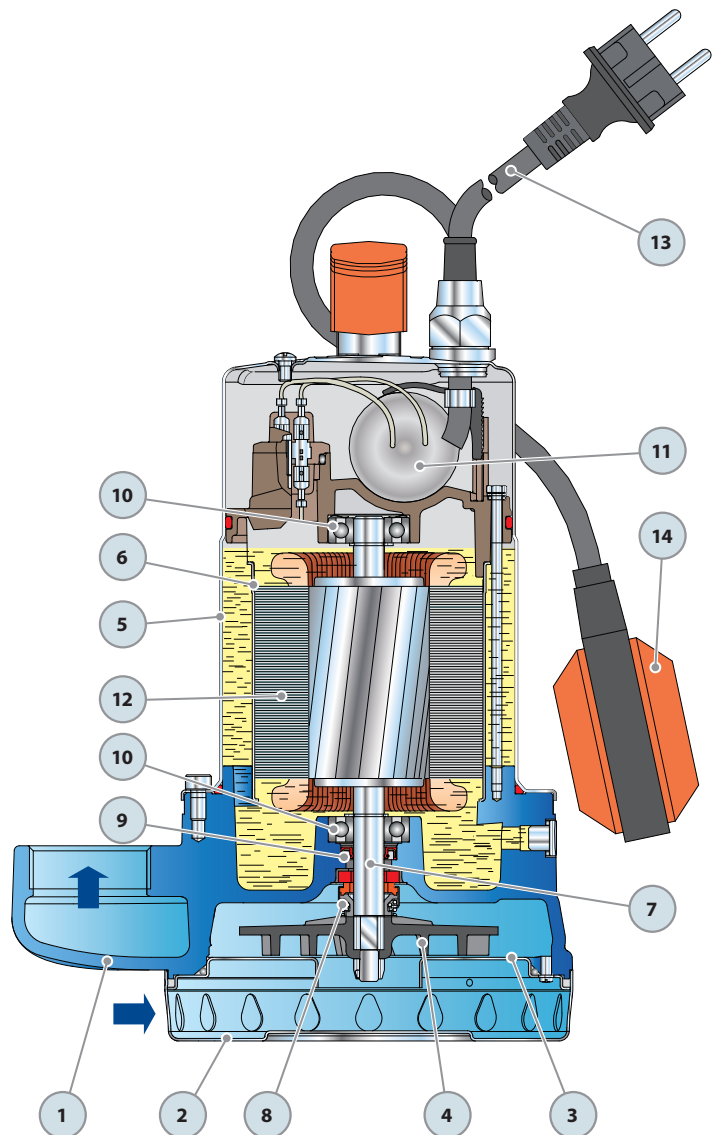

DIMENSIONS AND WEIGHT

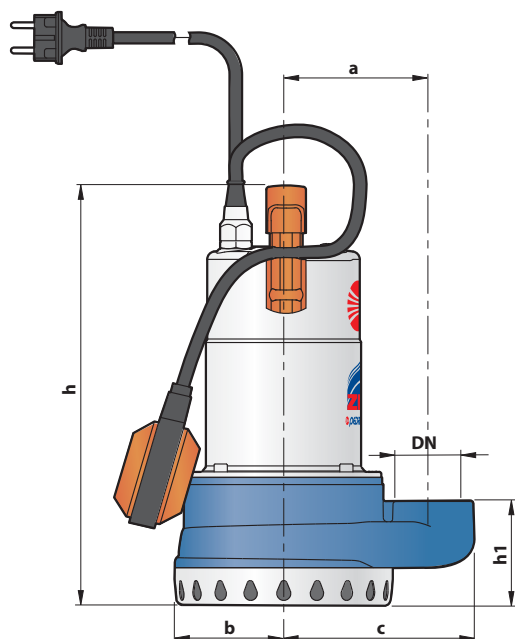

Typical installation

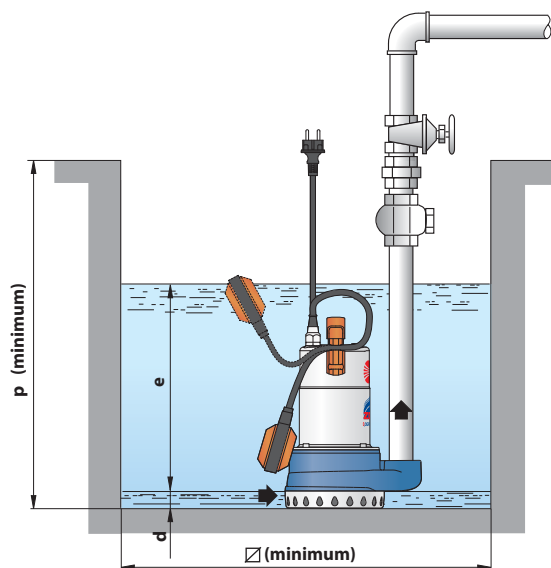

MODEL	PORT	DIMENSIONS mm									kg	
		a	b	c	h	h1	d	e	p	∅		
Single-phase	DN											
ZDm 1B-E	1½"	110	81	142	316	77	21	variable	450	450		
ZDm 1A-E											10.9	
ZDm 1AR-E											11.5	
												11.8

ABSORPTION

MODEL	VOLTAGE (single-phase)		
	230 V	240 V	110 V
Single-phase			
ZDm 1B-E	2.5 A	2.5 A	5.2 A
ZDm 1A-E	3.3 A	3.3 A	7.0 A
ZDm 1AR-E	4.4 A	4.4 A	9.0 A

PALLETIZATION

MODEL	GROUPAGE			CONTAINER		
	n° pumps	H (mm)	kg	n° pumps	H (mm)	kg
Single-phase						
ZDm 1B-E	60	1250	670	100	1990	1106
ZDm 1A-E	60	1250	709	100	1990	1170
ZDm 1AR-E	60	1250	726	100	1990	1199

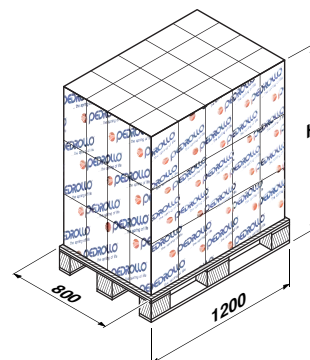

ZX "VORTEX"

Submersible pumps

▬▬▬ for very dirty water



PERFORMANCE RANGE

- Flow rate up to **400 l/min** (24 m³/h)
- Head up to **11 m**

APPLICATION LIMITS

- **5 m** maximum immersion depth
- Maximum liquid temperature **+40 °C**
- Passage of suspended solids up to **Ø 40 mm**
- Suction down to **50 mm** above ground level
- **240 mm** minimum immersion depth for continuous service

CONSTRUCTION AND SAFETY STANDARDS

- Complete with **5 m** long power cable

EN 60335-1
IEC 60335-1
CEI 61-150

EN 60034-1
IEC 60034-1
CEI 2-3



CERTIFICATIONS



INSTALLATION AND USE

ZX series pumps are suitable for draining **waste water** in domestic applications and for pumping dirty water containing suspended solids up to Ø 40 mm. They distinguish themselves for the ease with which they are installed and their reliability under automatic operating conditions in fixed installations.

PATENTS - TRADE MARKS - MODELS

- Registered Community Design n° 342159-0015

OPTIONALS AVAILABLE ON REQUEST

- Special mechanical seal.
- Pumps with a **10 m** long power cable
 - ▬▬ N.B. Standard EN 60335-2-41 states that the power cable must be 10 m long for outdoor applications
- Single-phase pumps without float switch
- Other voltages or 60 Hz frequency

GUARANTEE

1 year subject to terms and conditions

CHARACTERISTIC CURVES AND PERFORMANCE DATA

50 Hz n= 2900 1/min

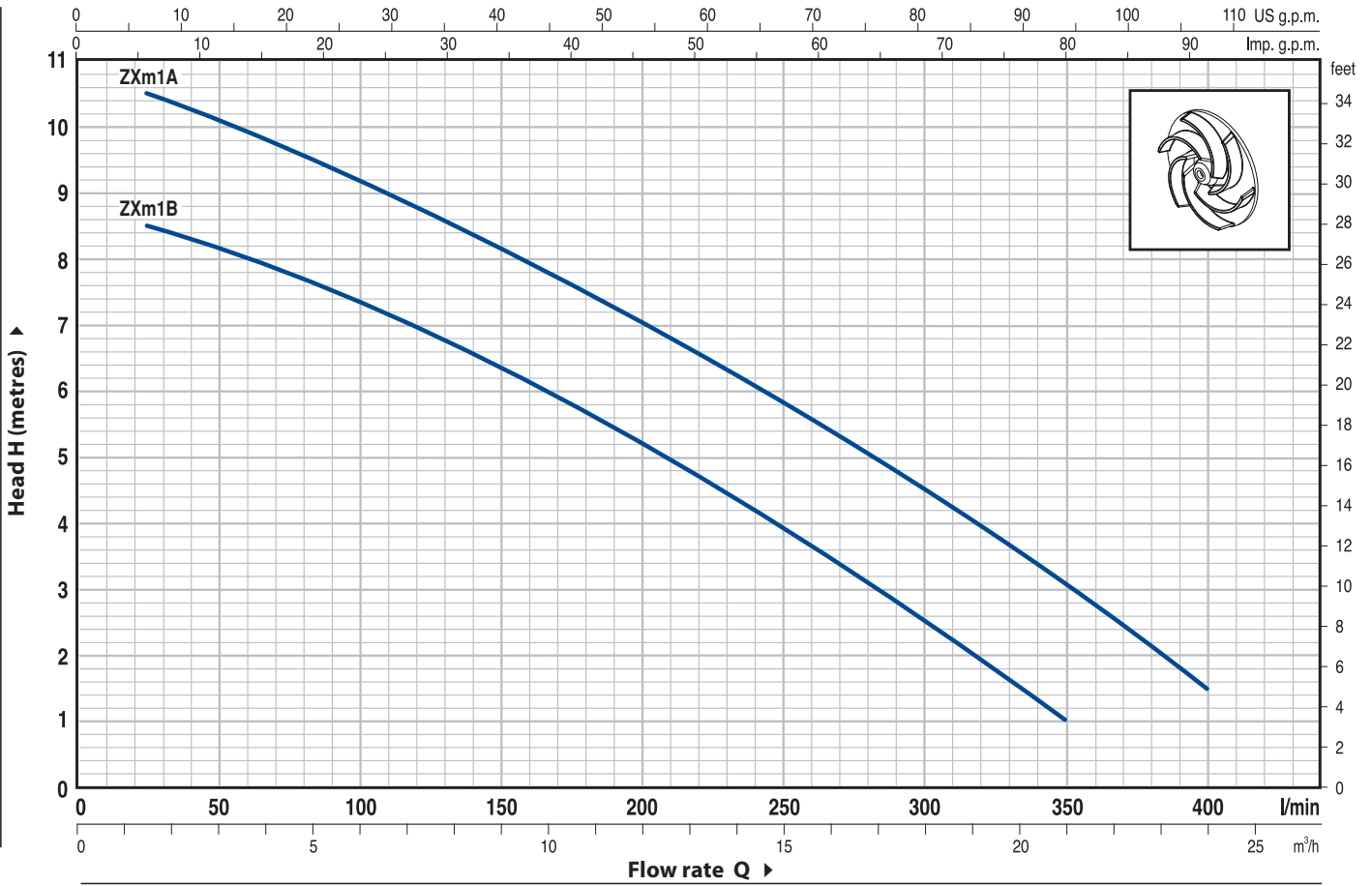

MODEL	POWER		Q	Flow rate													
	kW	HP		m³/h	0	1.5	3.0	4.5	6.0	9.0	12.0	15.0	18.0	21.0	24.0		
Single-phase			l/min	0	25	50	75	100	150	200	250	300	350	400			
ZXm 1B/40	0.50	0.70	H metres	9	8.5	8.3	8	7.5	6.5	5.2	4	2.5	1				
ZXm 1A/40	0.60	0.85		11	10.5	10	9.5	9.2	8.2	7	5.7	4.3	2.8	1.5			

Q = Flow rate H = Total manometric head

Tolerance of characteristic curves in compliance with EN ISO 9906 App. A.

POS.	COMPONENT	CONSTRUCTION CHARACTERISTICS			
1	PUMP BODY	Cast iron, with threaded port in compliance with ISO 228/1			
2	BASE	Stainless steel AISI 304			
3	IMPELLER	Technopolymer VORTEX type			
4	MOTOR SLEEVE	Stainless steel AISI 304			
5	MOTOR CASING	Steel			
6	MOTOR SHAFT	Stainless steel EN 10088-3 - 1.4104			
7	SHAFT WITH DOUBLE SEAL				
	<i>Seal</i>	<i>Shaft</i>			
	<i>Model</i>	<i>Diameter</i>	<i>Stationary ring</i>	<i>Rotational ring</i>	<i>Elastomer</i>
	AR-12R	Ø 12 mm	Ceramic	Graphite	NBR
8	LIP SEAL	Ø 12 x Ø 22 x H 6 mm			
9	BEARINGS	6201 ZZ / 6201 ZZ			
10	CAPACITOR				
	<i>Pump</i>	<i>Capacitance</i>			
	<i>Single-phase</i>	<i>(230 V or 240 V)</i>	<i>(110 V)</i>		
	ZXm 1B/40	12.5 µF 450 VL	30 µF 250 VL		
	ZXm 1A/40	16 µF 450 VL	30 µF 250 VL		
11	ELECTRIC MOTOR				
		– Single-phase 230 V - 50 Hz with thermal overload protector built-in to the winding.			
		– Insulation: F class.			
		– Protection: IP 68.			
12	POWER CABLE				
		5 metre long "H07 RN-F" cable with Schuko plug			
13	FLOAT SWITCH	(only for single-phase versions)			
14	HOSE CONNECTION				
		Ø 50 mm			

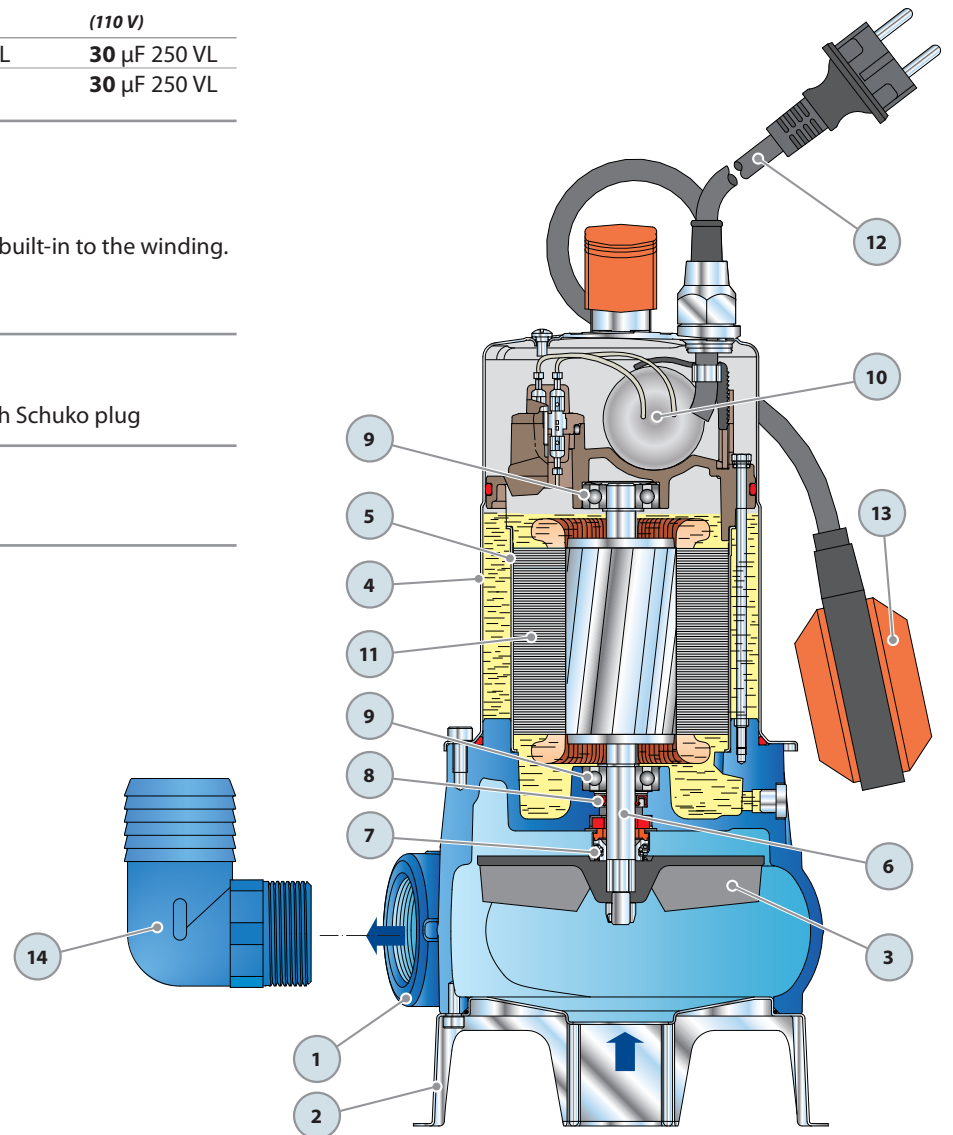

DIMENSIONS AND WEIGHT

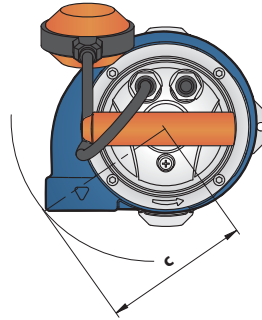
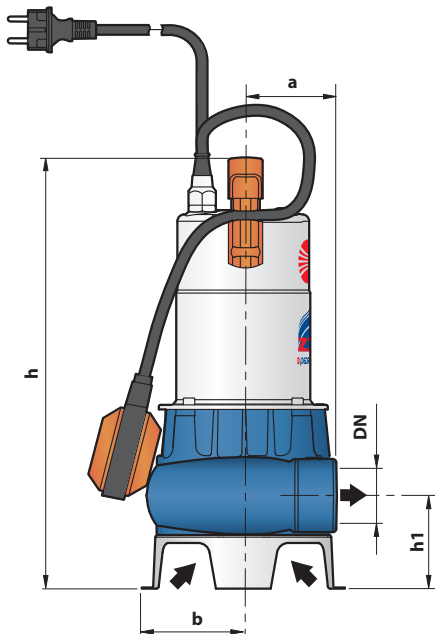

Typical installation

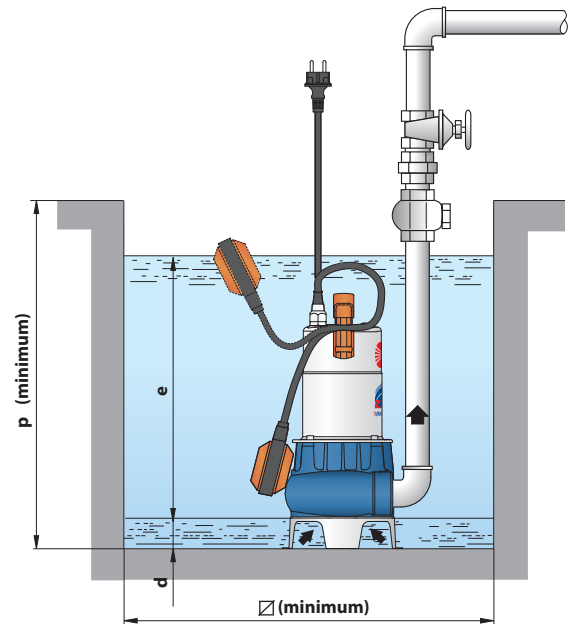

MODEL	PORT DN	solids passage	DIMENSIONS mm									kg	
			a	b	c	h	h1	d	e	p	∅		
Single-phase	1½"	Ø 40 mm	75	87	130	378	82	50	variable	450	450	1~	
ZXm 1B/40													11.5
ZXm 1A/40													

ABSORPTION

MODEL	VOLTAGE (single-phase)		
	230 V	240 V	110 V
Single-phase			
ZXm 1B/40	3.3 A	3.3 A	7.0 A
ZXm 1A/40	4.5 A	4.5 A	9.0 A

PALLETIZATION

MODEL	GROUPAGE			CONTAINER		
	n° pumps	H (mm)	kg	n° pumps	H (mm)	kg
Single-phase						
ZXm 1B/40	60	1460	709	80	1900	940
ZXm 1A/40	60	1460	721	80	1900	956

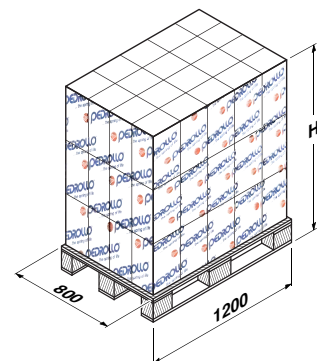

Submersible drainage pumps

for clear water



PERFORMANCE RANGE

- Flow rate up to **400 l/min** (24 m³/h)
- Head up to **27 m**

APPLICATION LIMITS

- **5 m** maximum immersion depth
- Maximum liquid temperature **+40 °C**
- Solids passage:
 - up to **Ø 10 mm** for D6-D8-D10-D15
 - up to **Ø 6 mm** for D18-D20
 - up to **Ø 3 mm** for D30
- Suction level:
 - **23 mm** above ground level for D6-D8-D10-D18-D20
 - **15 mm** above ground level for D15-D30
- **220 mm** minimum immersion depth for continuous service

CONSTRUCTION AND SAFETY STANDARDS

- Complete with **5 m** long power cable
- Float switch for single-phase versions

EN 60335-1
IEC 60335-1
CEI 61-150

EN 60034-1
IEC 60034-1
CEI 2-3



CERTIFICATIONS



INSTALLATION AND USE

Designed to pump **clear or slightly dirty water**, these pumps are suitable for use in domestic, civil and professional applications and in particular for draining flooded areas such as cellars and garages, for draining swimming pools and reservoirs and for the disposal of non-sewage waste water.

These pumps distinguish themselves for their reliability, which can be best appreciated under automatic operating conditions in fixed installations.

PATENTS - TRADE MARKS - MODELS

- Patent pending n° BO2008A000494, BO2008A000496

OPTIONALS AVAILABLE ON REQUEST

- Pumps with a **10 m** long power cable
 - ⇒ N.B. Standard EN 60335-2-41 states that the power cable must be 10 m long for outdoor applications
- Single-phase pumps without float switch
- Other voltages or 60 Hz frequency

GUARANTEE

1 year subject to terms and conditions

CHARACTERISTIC CURVES AND PERFORMANCE DATA

50 Hz n= 2900 1/min

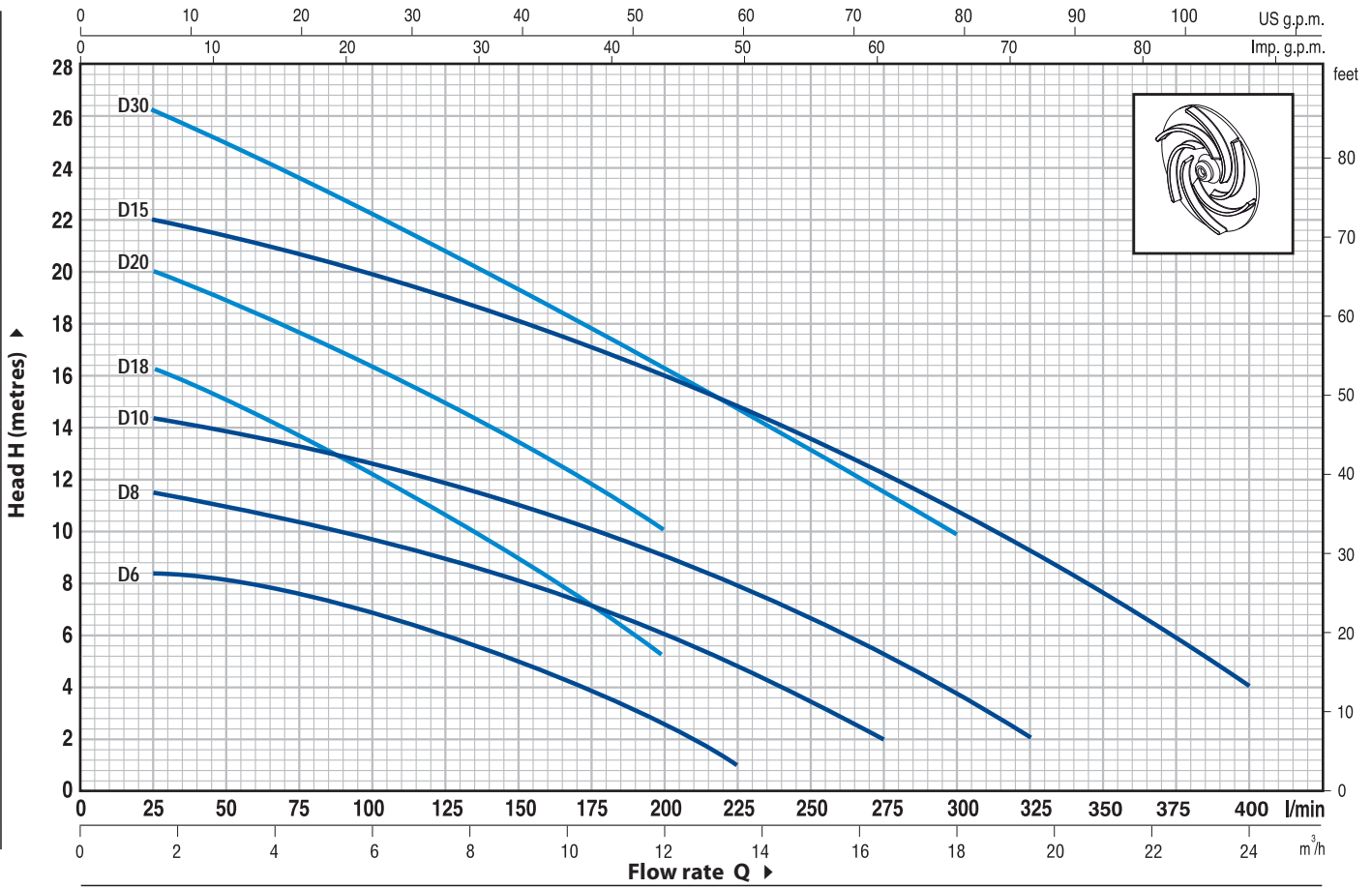

MODEL		POWER		Q	m³/h																		
Single-phase	Three-phase	kW	HP		0	1.5	3.0	4.5	6.0	7.5	9.0	10.5	12.0	13.5	15.0	16.5	18.0	19.5	21.0	24.0			
				l/min	0	25	50	75	100	125	150	175	200	225	250	275	300	325	350	400			
Dm 6	-	0.45	0.60	H metres	9	8.5	8	7.5	6.8	6	5.2	4	2.6	1									
Dm 8	-	0.55	0.75		12	11.5	11	10.5	9.8	9	8.2	7.2	6	4.8	3.5	2							
Dm 10	D 10	0.75	1		15	14.5	14	13.2	12.5	11.8	11	10	9	8	6.8	5.4	3.5	2					
Dm 15	D 15	1.1	1.5		23	22	21.5	20.5	20	19	18	17	16	15	13.5	12	11	9	7.5	4			
Dm 18	-	0.55	0.75		17	16.5	15	13.5	12	10.7	9	7.7	5										
Dm 20	D 20	0.75	1		21	20	19	17.5	16	15	13.5	12	10										
Dm 30	D 30	1.1	1.5		27	26	25	23.5	22	21	19.5	18	16	14.5	13	11.5	10						

Q = Flow rate H = Total manometric head

Tolerance of characteristic curves in compliance with EN ISO 9906 App. A.

POS.	COMPONENT	CONSTRUCTION CHARACTERISTICS			
1	PUMP BODY	Cast iron, with threaded port in compliance with ISO 228/1			
2	SUCTION FILTER	Stainless steel AISI 304 (with mesh filter for D30)			
3	SUCTION PLATE	Stainless steel AISI 304			
4	IMPELLER	Technopolymer open type (closed for D30)			
5	MOTOR CASING	Stainless steel AISI 304			
6	MOTOR CASING PLATE	Stainless steel AISI 304			
7	MOTOR SHAFT	Stainless steel EN 10088-3 - 1.4104			
8	SHAFT WITH DOUBLE SEAL AND OIL CHAMBER				
	Seal	Shaft			
	<i>Model</i>	<i>Diameter</i>	<i>Stationary ring</i>	<i>Rotational ring</i>	<i>Elastomer</i>
	MG1-14 SIC	Ø 14 mm	Ceramic	Silicon carbide	NBR
9	LIP SEAL	Ø 15 x Ø 24 x H 5 mm (Ø 16 x Ø 24 x H 5 mm for D15, D30)			
10	BEARINGS	6203 ZZ / 6203 ZZ			
11	CAPACITOR				
	Pump	Capacitance			
	<i>Single-phase</i>	<i>(230 V or 240 V)</i>	<i>(110 V)</i>		
	Dm6				
	Dm8				
	Dm10	20 µF 450 VL	30 µF 250 VL		
	Dm18				
	Dm20				
	Dm15	25 µF 450 VL	-		
	Dm30				
12	ELECTRIC MOTOR				
	<ul style="list-style-type: none"> - Single-phase 230 V - 50 Hz with thermal overload protector built-in to the winding - Three-phase 400 V - 50 Hz - Insulation: F class - Protection: IP 68 				
13	POWER CABLE				
	5 metre long "H07 RN-F" cable (with Schuko plug on single-phase versions only)				
14	FLOAT SWITCH				
	(only for single-phase versions)				

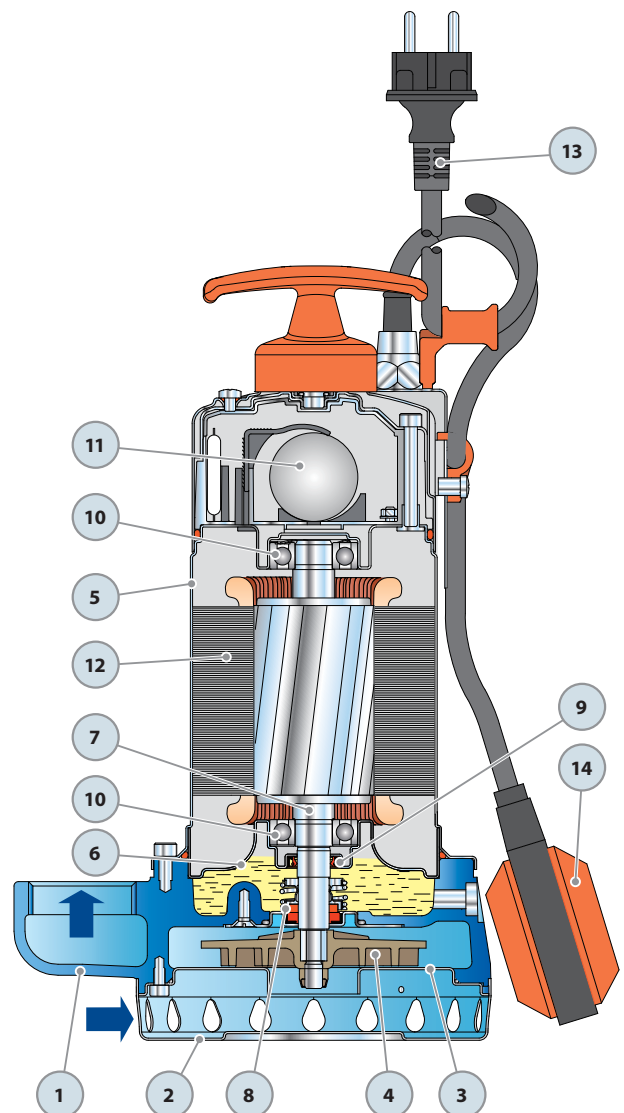

DIMENSIONS AND WEIGHT

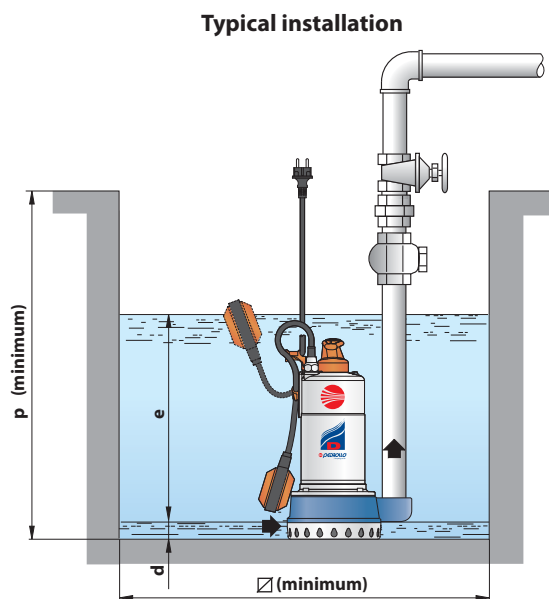
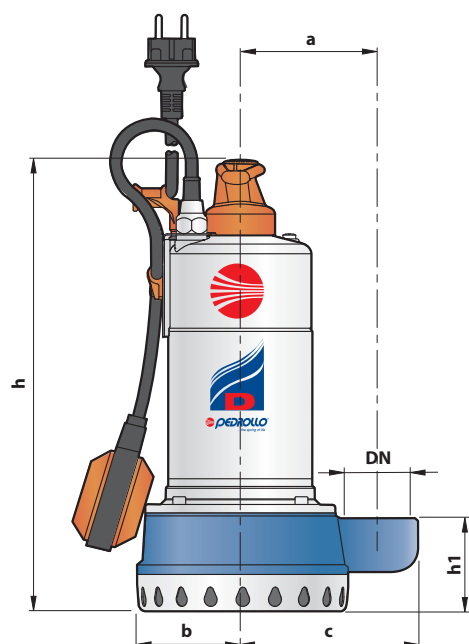

MODEL		PORT DN	DIMENSIONS mm									kg	
Single-phase	Three-phase		a	b	c	h	h1	d	e	p	Ø	1~	3~
Dm 6	-	1½"	105	81	136	352	72	23	variable	500	500	11.7	-
Dm 8	-											11.7	-
Dm 10	D 10											12.7	11.6
Dm 15	D 15		14.7	13.7									
Dm 18	-		11.8	-									
Dm 20	D 20		13.0	11.7									
Dm 30	D 30	110	90	140	371	85	15	15.0	14.0				

ABSORPTION

MODEL	VOLTAGE (single-phase)		
	230 V	240 V	110 V
Single-phase			
Dm 6	2.4 A	2.4 A	5.2 A
Dm 8	3.4 A	3.4 A	6.9 A
Dm 10	5.2 A	5.2 A	10.5 A
Dm 15	7.9 A	7.9 A	-
Dm 18	3.8 A	3.8 A	7.2 A
Dm 20	5.4 A	5.4 A	11.0 A
Dm 30	7.2 A	7.2 A	-

MODEL	VOLTAGE (three-phase)			
	230 V	400 V	240 V	415 V
Three-phase				
D 10	3.6 A	2.1 A	3.6 A	2.1 A
D 15	6.0 A	3.5 A	6.0 A	3.5 A
D 20	3.6 A	2.1 A	3.6 A	2.1 A
D 30	6.0 A	3.5 A	6.0 A	3.5 A

PALLETIZATION

MODEL		GROUPAGE			CONTAINER				
Single-phase	Three-phase	n° pumps	H (mm)	kg		n° pumps	H (mm)	kg	
				1~	3~			1~	3~
Dm 6	-	60	1310	721	-	100	2090	1190	-
Dm 8	-	60	1310	720	-	100	2090	1190	-
Dm 10	D 10	60	1310	780	711	100	2090	1288	1174
Dm 15	D 15	45	1388	678	632	60	1804	898	837
Dm 18	-	60	1310	725	-	100	2090	1197	-
Dm 20	D 20	60	1310	797	720	100	2090	1317	1188
Dm 30	D 30	45	1388	690	647	60	1804	914	857

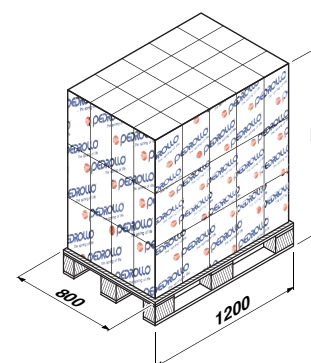

Submersible drainage pumps

for clear water



PERFORMANCE RANGE

- Flow rate up to **400 l/min** (24 m³/h)
- Head up to **27 m**

APPLICATION LIMITS

- **10 m** maximum immersion depth
- Maximum liquid temperature **+40 °C**
- Solids passage:
 - up to **Ø 10 mm** for DC8-DC10-DC15
 - up to **Ø 6 mm** for DC20
 - up to **Ø 3 mm** for DC30
- Suction level:
 - **23 mm** above ground level for DC8-DC10-DC20
 - **15 mm** above ground level for DC15-DC30
- **220 mm** minimum immersion depth for continuous service

CONSTRUCTION AND SAFETY STANDARDS

- Complete with **10 m** long power cable
- Float switch for single-phase versions

EN 60034-1
IEC 60034-1
CEI 2-3



CERTIFICATIONS



INSTALLATION AND USE

DC submersible pumps, made from heavy gauge cast iron offering exceptional sturdiness, abrasion resistance and durability, are suitable for draining **clear or slightly dirty water**. They distinguish themselves for their sturdiness and reliability under automatic operating conditions in fixed installations.

PATENTS - TRADE MARKS - MODELS

- Registered Community Design n° 342159-0016

OPTIONALS AVAILABLE ON REQUEST

- Single-phase pumps without float switch
- Other voltages or 60 Hz frequency

GUARANTEE

1 year subject to terms and conditions

CHARACTERISTIC CURVES AND PERFORMANCE DATA

50 Hz n= 2900 1/min

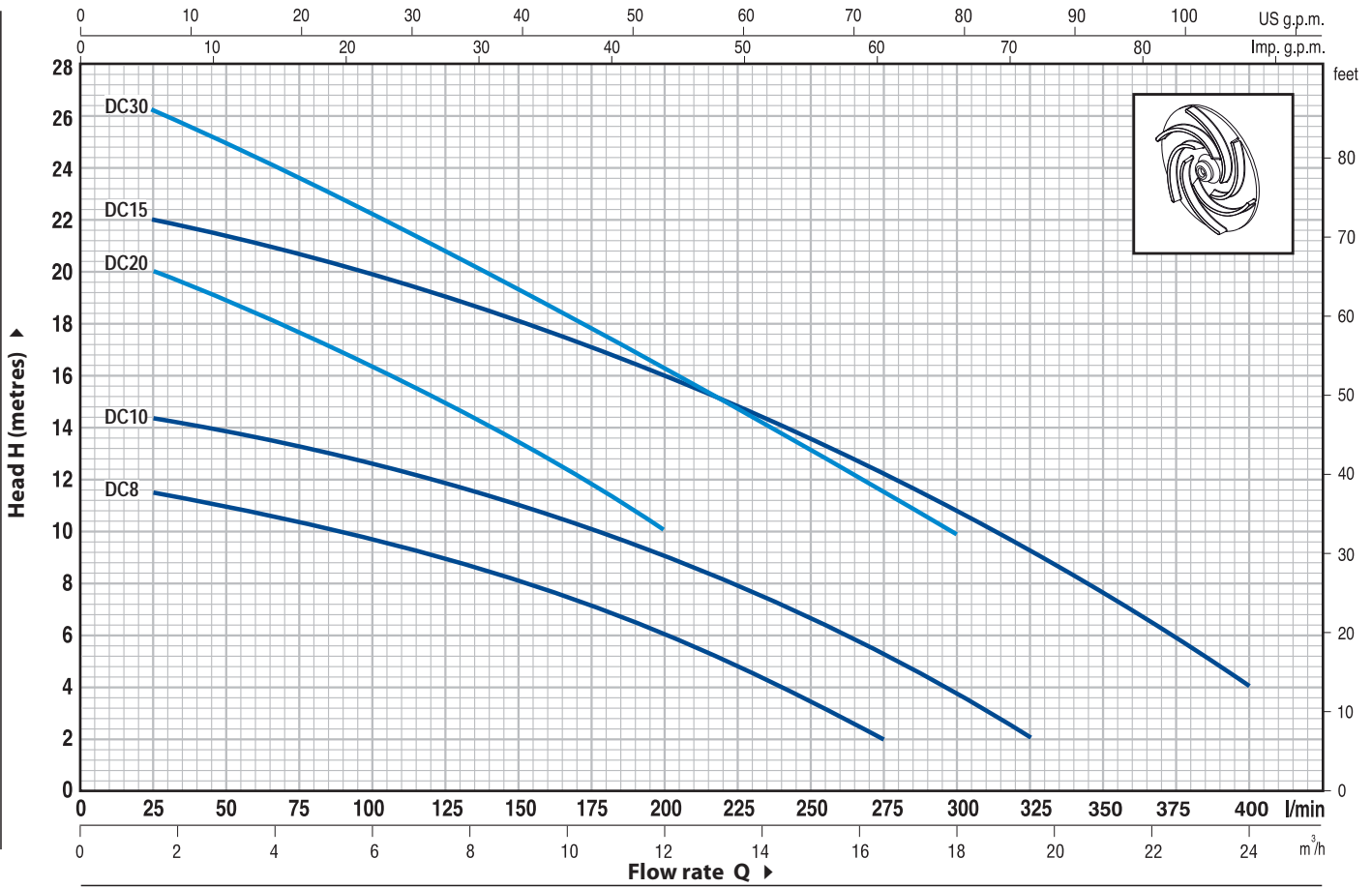

MODEL		POWER		Q	Flow rate																		
Single-phase	Three-phase	kW	HP		m³/h	0	1.5	3.0	4.5	6.0	7.5	9.0	10.5	12.0	13.5	15.0	16.5	18.0	19.5	21.0	24.0		
				l/min	0	25	50	75	100	125	150	175	200	225	250	275	300	325	350	400			
DCm 8	-	0.55	0.75	H metres	12	11.5	11	10.5	9.8	9	8.2	7.2	6	4.8	3.5	2							
DCm 10	DC 10	0.75	1		15	14.5	14	13.2	12.5	11.8	11	10	9	8	6.8	5.4	3.5	2					
DCm 15	DC 15	1.1	1.5		19.5	19	18.5	18	17.5	16.5	16	15	14	13	11.8	10.5	9.2	8	7	4			
DCm 20	DC 20	0.75	1		21	20	19	17.5	16	15	13.5	12	10										
DCm 30	DC 30	1.1	1.5		27	26	25	23.5	22	21	19.5	18	16	14.5	13	11.5	10						

Q = Flow rate H = Total manometric head

Tolerance of characteristic curves in compliance with EN ISO 9906 App. A.

POS.	COMPONENT	CONSTRUCTION CHARACTERISTICS
------	-----------	------------------------------

1	PUMP BODY	Cast iron, with threaded port in compliance with ISO 228/1
2	SUCTION FILTER	Stainless steel AISI 304 (with mesh filter for DC30)
3	SUCTION PLATE	Stainless steel AISI 304
4	IMPELLER	Technopolymer open type (closed for D30)
5	MOTOR CASING	Cast iron
6	MOTOR CASING PLATE	Stainless steel AISI 304
7	MOTOR SHAFT	Stainless steel EN 10088-3 - 1.4104

8 SHAFT WITH DOUBLE SEAL AND OIL CHAMBER

Seal Model	Shaft Diameter	Materials		
		Stationary ring	Rotational ring	Elastomer
MG1-14 SIC	Ø 14 mm	Ceramic	Silicon carbide	NBR

9	LIP SEAL	Ø 15 x Ø 24 x H 5 mm for DC8, DC10, DC 20
		Ø 16 x Ø 24 x H 5 mm for DC15, DC30

10	BEARINGS	6203 ZZ / 6203 ZZ
----	-----------------	-------------------

11 CAPACITOR

Pump	Capacitance	
Single-phase	(230 V or 240 V)	(110 V)
DCm8		
DCm10	20 µF 450 VL	30 µF 250 VL
DCm20		
DCm15	25 µF 450 VL	-
DCm30		

12 ELECTRIC MOTOR

- Single-phase 230 V - 50 Hz
with thermal overload protector built-in to the winding
- Three-phase 400 V - 50 Hz
- Insulation: F class
- Protection: IP 68

13 POWER CABLE

10 metre long "H07 RN-F" cable
(with Schuko plug on single-phase versions only)

14 FLOAT SWITCH

(only for single-phase versions)

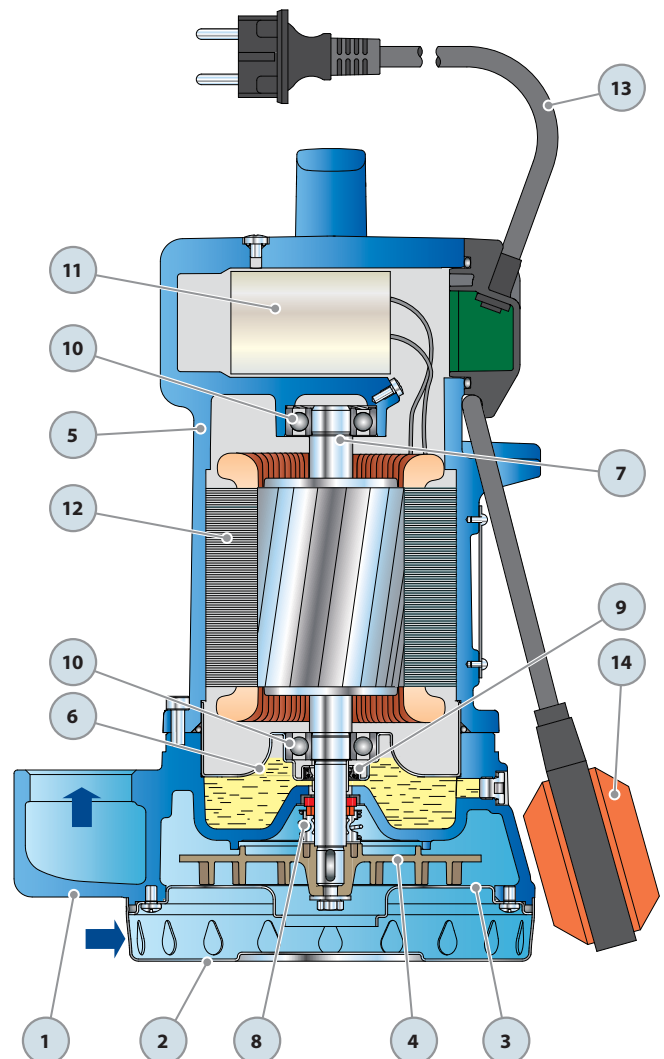

DIMENSIONS AND WEIGHT

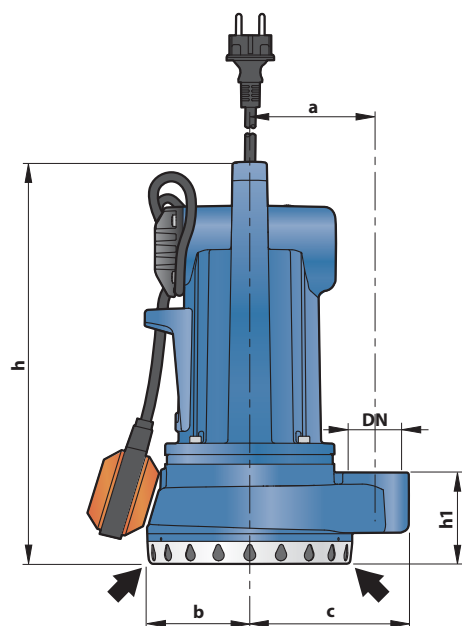

Typical installation

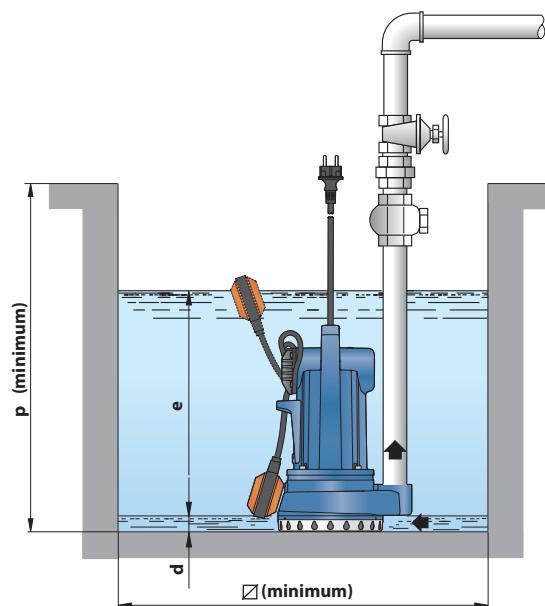

MODEL		PORT	DIMENSIONS mm									kg	
Single-phase	Three-phase	DN	a	b	c	h	h1	d	e	p	Ø	1~	3~
DCm 8	-	1½"	105	92	136	329	72	23	variable	500	500	18.6	-
DCm 10	DC 10				19.5							17.9	
DCm 15	DC 15		110		140	348	85	15				21.6	19.9
DCm 20	DC 20		105		136	329	72	23				19.5	17.9
DCm 30	DC 30		110		140	348	85	15				21.5	19.9

ABSORPTION

MODEL	VOLTAGE (single-phase)		
	230 V	240 V	110 V
Single-phase	230 V	240 V	110 V
DCm 8	3.4 A	3.4 A	6.9 A
DCm 10	5.2 A	5.2 A	10.5 A
DCm 15	7.9 A	7.9 A	-
DCm 20	5.4 A	5.4 A	11.0 A
DCm 30	7.2 A	7.2 A	-

MODEL	VOLTAGE (three-phase)			
	230 V	400 V	240 V	415 V
Three-phase	230 V	400 V	240 V	415 V
DC 10	3.6 A	2.1 A	3.6 A	2.1 A
DC 15	6.1 A	3.5 A	6.1 A	3.5 A
DC 20	3.6 A	2.1 A	3.6 A	2.1 A
DC 30	6.1 A	3.5 A	6.1 A	3.5 A

PALLETIZATION

MODEL		GROUPAGE			CONTAINER				
Single-phase	Three-phase	n° pumps	H (mm)	kg		n° pumps	H (mm)	kg	
				1~	3~			1~	3~
DCm 8	-	45	1388	854	-	60	1804	1133	-
DCm 10	DC 10	45	1388	894	824	60	1804	1187	1093
DCm 15	DC 15	45	1388	987	913	60	1804	1310	1211
DCm 20	DC 20	45	1388	895	824	60	1804	1187	1093
DCm 30	DC 30	45	1388	985	910	60	1804	1308	1208

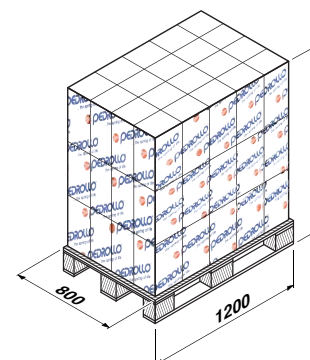

VX "VORTEX"

Submersible pumps

for sewage water



PERFORMANCE RANGE

- Flow rate up to **500 l/min** (30 m³/h)
- Head up to **15 m**

APPLICATION LIMITS

- **5 m** maximum immersion depth
- Maximum liquid temperature **+40 °C**
- Solids passage:
 - up to **Ø 40 mm** for VX8-10-15/35
 - up to **Ø 50 mm** for VX8-10-15/50
- Minimum immersion depth for continuous service:
 - **290 mm** for VX8-10-15/35
 - **320 mm** for VX8-10-15/50

CONSTRUCTION AND SAFETY STANDARDS

- Complete with **5 m** long power cable
- VXm versions complete with float switch

EN 60335-1
IEC 60335-1
CEI 61-150

EN 60034-1
IEC 60034-1
CEI 2-3



CERTIFICATIONS



INSTALLATION AND USE

Suitable for use in domestic, civil and industrial applications where the water, such as **groundwater, surface water and sewage water**, contains suspended solids up to Ø 50 mm.

They are suitable for use in applications such as for draining flooded areas such as cellars, underground car parks, car washes, for emptying cesspools and for sewage disposal.

These pumps distinguish themselves for their reliability, which can be best appreciated under automatic operating conditions in fixed installations.

PATENTS - TRADE MARKS - MODELS

- Patent pending n° BO2008A000494, BO2008A000496

OPTIONALS AVAILABLE ON REQUEST

- Pumps with a **10 m** long power cable
 - ➔ N.B. Standard EN 60335-2-41 states that the power cable must be 10 m long for outdoor applications
- Single-phase pumps without float switch
- Other voltages or 60 Hz frequency

GUARANTEE

1 year subject to terms and conditions

CHARACTERISTIC CURVES AND PERFORMANCE DATA

50 Hz n= 2900 1/min

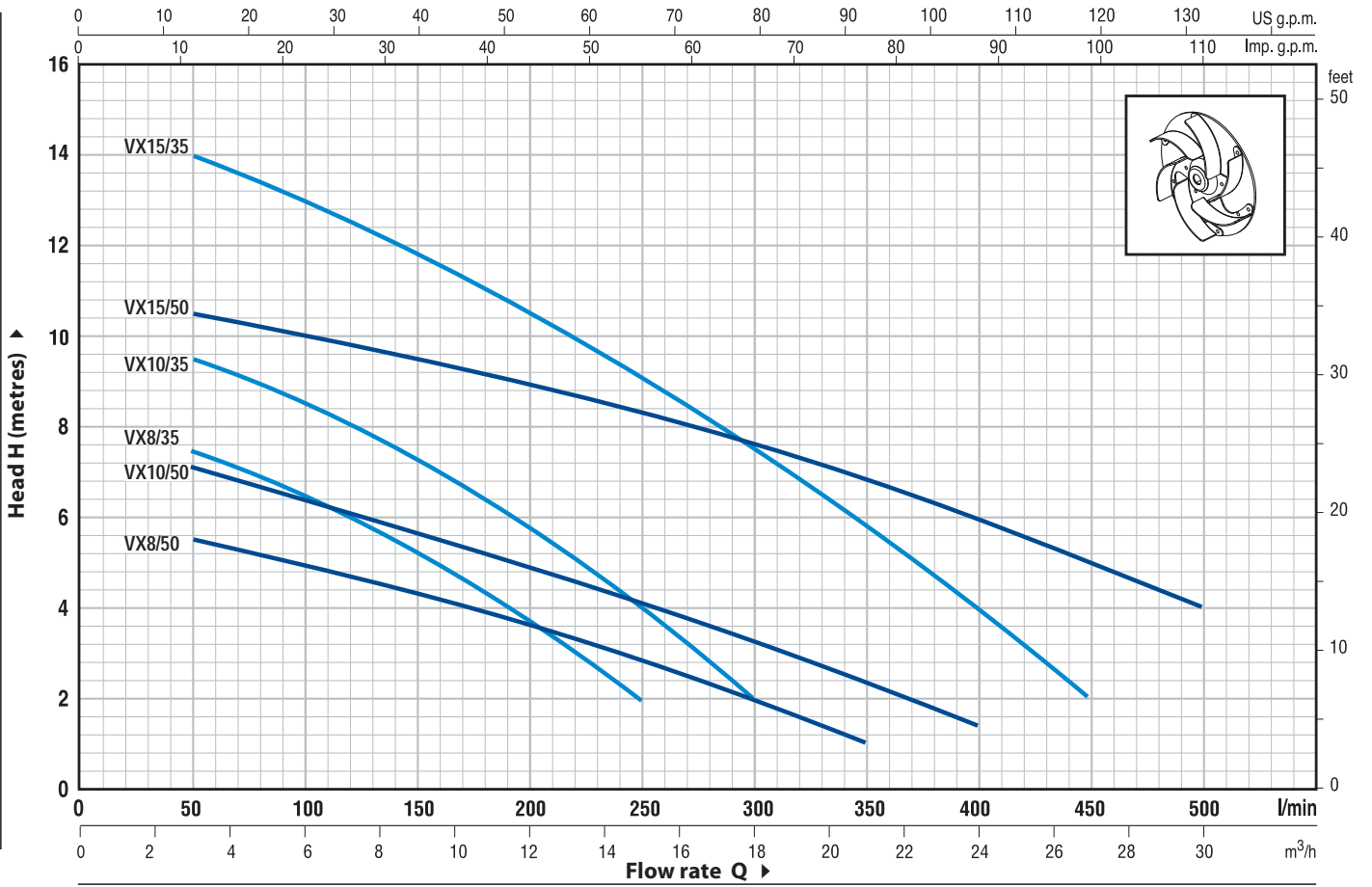

MODEL		POWER		Q	Flow rate														
Single-phase	Three-phase	kW	HP		m ³ /h	0	3	6	9	12	15	18	21	24	27	30			
VXm 8/35	-	0.55	0.75	H metres	0	50	100	150	200	250	300	350	400	450	500				
VXm 10/35	VX 10/35	0.75	1		8.4	7.5	6.5	5.2	3.7	2									
VXm 15/35	VX 15/35	1.1	1.5		10	9.5	8.5	7.2	5.8	4	2								
VXm 8/50	-	0.55	0.75		15	14	13	11.8	10.5	9	7.5	6	4	2					
VXm 10/50	VX 10/50	0.75	1		6	5.5	5	4.4	3.6	2.8	2	1							
VXm 15/50	VX 15/50	1.1	1.5		7.5	7	6.5	5.8	5	4	3.2	2.4	1.5						
					11	10.5	10	9.5	9	8.3	7.5	6.8	6	5	4				

Q = Flow rate H = Total manometric head

Tolerance of characteristic curves in compliance with EN ISO 9906 App. A.

POS.	COMPONENT	CONSTRUCTION CHARACTERISTICS			
1	PUMP BODY	Cast iron, with threaded port in compliance with ISO 228/1			
2	BASE	Stainless steel AISI 304			
3	IMPELLER	Stainless steel AISI 304 VORTEX type			
4	MOTOR CASING	Stainless steel AISI 304			
5	MOTOR CASING PLATE	Stainless steel AISI 304			
6	MOTOR SHAFT	Stainless steel EN 10088-3 - 1.4104			
7	SHAFT WITH DOUBLE SEAL AND OIL CHAMBER				
	<i>Seal</i>	<i>Shaft</i>	<i>Materials</i>		
	<i>Model</i>	<i>Diameter</i>	<i>Stationary ring</i>	<i>Rotational ring</i>	<i>Elastomer</i>
	MG1-14 SIC	Ø 14 mm	Ceramic	Silicon carbide	NBR
8	LIP SEAL	Ø 15 x Ø 24 x H 5 mm for VX 8-10/35-50 Ø 16 x Ø 24 x H 5 mm for VX 15/35-50			

9	BEARINGS	6203 ZZ / 6203 ZZ
---	----------	-------------------

10	CAPACITOR		
	<i>Pump</i>	<i>Capacitance</i>	
	<i>Single-phase</i>	(230 V or 240 V) (110 V)	
	VXm 8/35		
	VXm 8/50	20 µF 450 VL	30 µF 250 VL
	VXm 10/35		
	VXm 10/50		
	VXm 15/35	25 µF 450 VL	-
	VXm 15/50		

11	ELECTRIC MOTOR
	- Single-phase 230 V - 50 Hz with thermal overload protector built-in to the winding
	- Three-phase 400 V - 50 Hz
	- Insulation: F class
	- Protection: IP 68

12	POWER CABLE
	5 metre long "H07 RN-F" cable (with Schuko plug on single-phase versions only)

13	FLOAT SWITCH
	(only for single-phase versions)

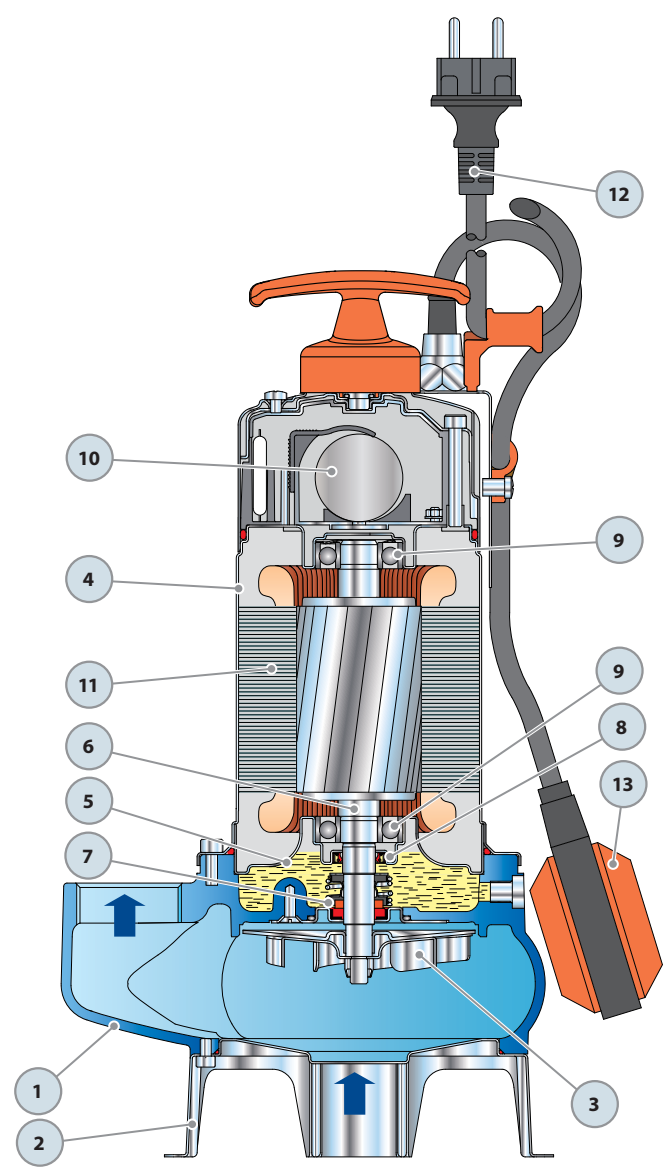

DIMENSIONS AND WEIGHT

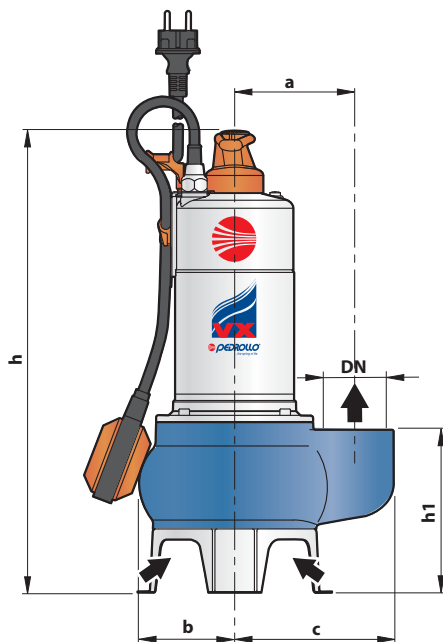

Typical installation

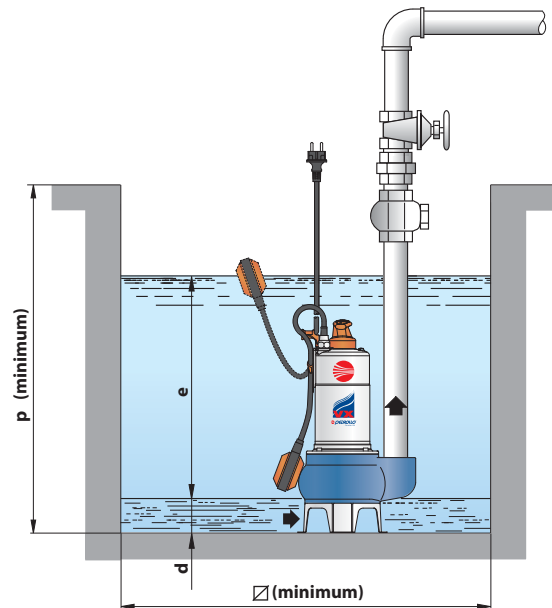

MODEL		PORT DN	solids passage	DIMENSIONS mm									kg	
Single-phase	Three-phase			a	b	c	h	h1	d	e	p	Ø	1~	3~
VXm 8/35	-	1½"	Ø 40 mm	105	92	136	408	125	50	variable	500	500	12.4	-
VXm 10/35	VX 10/35					143	429	130					13.3	12.1
VXm 15/35	VX 15/35			150		437	153	16.3	15.0					
VXm 8/50	-	2"	Ø 50 mm	110	97	150	437	153	60	variable	500	500	12.9	-
VXm 10/50	VX 10/50					157	458	159					13.9	12.1
VXm 15/50	VX 15/50			17.0		15.6								

ABSORPTION

MODEL	VOLTAGE (single-phase)		
	230 V	240 V	110 V
Single-phase			
VXm 8/35	3.3 A	3.3 A	7.6 A
VXm 10/35	5.0 A	5.0 A	11.5 A
VXm 15/35	6.7 A	6.7 A	-
VXm 8/50	3.5 A	3.5 A	8.0 A
VXm 10/50	5.0 A	5.0 A	11.5 A
VXm 15/50	7.1 A	7.1 A	-

MODEL	VOLTAGE (three-phase)			
	230 V	400 V	240 V	415 V
Three-phase				
VX 10/35	3.6 A	2.1 A	3.6 A	2.1 A
VX 15/35	5.4 A	3.1 A	5.4 A	3.1 A
VX 10/50	3.6 A	2.1 A	3.6 A	2.1 A
VX 15/50	5.4 A	3.1 A	5.4 A	3.1 A

PALLETIZATION

MODEL		GROUPAGE			CONTAINER				
Single-phase	Three-phase	n° pumps	H (mm)	kg		n° pumps	H (mm)	kg	
				1~	3~			1~	3~
VXm 8/35	-	60	1520	761	-	80	1980	1009	-
VXm 10/35	VX 10/35	60	1520	815	744	80	1980	1081	987
VXm 15/35	VX 15/35	45	1574	748	692	60	2052	992	917
VXm 8/50	-	60	1520	791	-	80	1980	1049	-
VXm 10/50	VX 10/50	60	1520	851	744	80	1980	1129	986
VXm 15/50	VX 15/50	45	1574	780	718	60	2052	1034	952

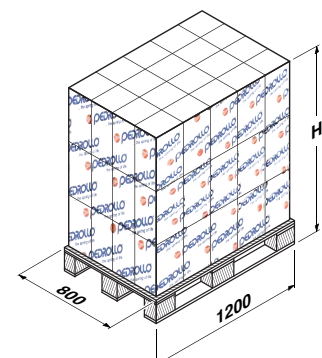

MC "DOUBLE-CHANNEL"

Submersible pumps

for sewage water



PERFORMANCE RANGE

- Flow rate up to **800 l/min** (48 m³/h)
- Head up to **15 m**

APPLICATION LIMITS

- **5 m** maximum immersion depth
- Maximum liquid temperature **+40 °C**
- Passage of suspended solids up to **Ø 50 mm**
- **320 mm** minimum immersion depth for continuous service

CONSTRUCTION AND SAFETY STANDARDS

- Complete with **5 m** long power cable
- Float switch for single-phase versions

EN 60335-1
IEC 60335-1
CEI 61-150

EN 60034-1
IEC 60034-1
CEI 2-3



CERTIFICATIONS



INSTALLATION AND USE

MC submersible pumps are suitable for draining **dirty water and sewage** in domestic and civil applications. They come equipped with a DOUBLE-CHANNEL stainless steel impeller and are capable of pumping liquids containing short fibred suspended solids up to Ø 50 mm.

They are ideal for pumping sewage water, waste water, surface water and water mixed with mud in locations such as holiday homes and detached homes.

These pumps distinguish themselves for their reliability, which can be best appreciated under automatic operating conditions in fixed installations.

PATENTS - TRADE MARKS - MODELS

- Patent pending n° BO2008A000494, BO2008A000496

OPTIONALS AVAILABLE ON REQUEST

- Pumps with a **10 m** long power cable
 - ➔ N.B. Standard EN 60335-2-41 states that the power cable must be 10 m long for outdoor applications
- Single-phase pumps without float switch
- Other voltages or 60 Hz frequency

GUARANTEE

1 year subject to terms and conditions

CHARACTERISTIC CURVES AND PERFORMANCE DATA

50 Hz n= 2900 1/min

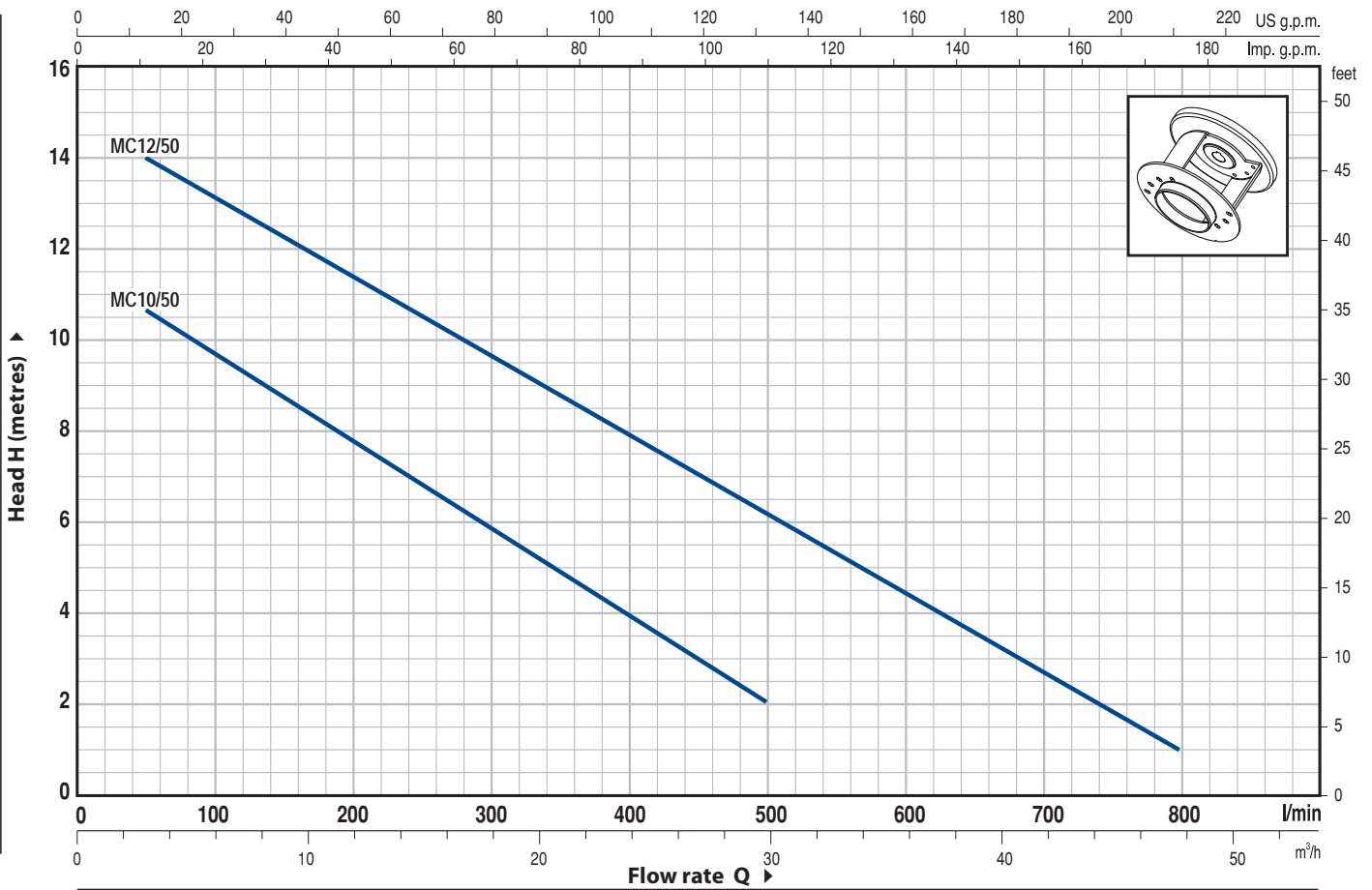

MODEL		POWER		Q	Flow rate															
Single-phase	Three-phase	kW	HP		m³/h	0	3	6	9	12	15	18	21	24	27	30	36	42	48	
MCm 10/50	MC 10/50	0.75	1	l/min	0	50	100	150	200	250	300	350	400	450	500	600	700	800		
MCm 12/50	MC 12/50	1.1	1.5	H metres	12	10.7	9.7	8.7	7.8	6.8	5.9	5	4	3	2					
					15	14	13	12.3	11.5	10.5	9.7	8.8	8	7	6.2	4.5	2.7	1		

Q = Flow rate H = Total manometric head

Tolerance of characteristic curves in compliance with EN ISO 9906 App. A.

MC "DOUBLE-CHANNEL"

POS.	COMPONENT	CONSTRUCTION CHARACTERISTICS			
1	PUMP BODY	Cast iron, with threaded port in compliance with ISO 228/1			
2	BASE	Stainless steel AISI 304			
3	IMPELLER	Stainless steel AISI 304 DOUBLE-CHANNEL type			
4	MOTOR CASING	Stainless steel AISI 304			
5	MOTOR CASING PLATE	Stainless steel AISI 304			
6	MOTOR SHAFT	Stainless steel EN 10088-3 - 1.4104			
7	SHAFT WITH DOUBLE SEAL AND OIL CHAMBER				
	<i>Seal</i>	<i>Shaft</i>	<i>Materials</i>		
	<i>Model</i>	<i>Diameter</i>	<i>Stationary ring</i>	<i>Rotational ring</i>	<i>Elastomer</i>
	MG1-14 SIC	Ø 14 mm	Ceramic	Silicon carbide	NBR
8	LIP SEAL	Ø 15 x Ø 24 x H 5 mm for MC 10/50 Ø 16 x Ø 24 x H 5 mm for MC 12/50			

9	BEARINGS	6203 ZZ / 6203 ZZ
---	----------	-------------------

10	CAPACITOR		
	<i>Pump</i>	<i>Capacitance</i>	
	<i>Single-phase</i>	<i>(230 V or 240 V)</i>	<i>(110 V)</i>
	MCm 10/50	20 µF 450 VL	30 µF 250 VL
	MCm 12/50	25 µF 450 VL	-

11	ELECTRIC MOTOR
	- Single-phase 230 V - 50 Hz with thermal overload protector built-in to the winding
	- Three-phase 400 V - 50 Hz
	- Insulation: F class
	- Protection: IP 68

12	POWER CABLE
	5 metre long "H07 RN-F" cable (with Schuko plug on single-phase versions only)

13	FLOAT SWITCH (only for single-phase versions)
----	---

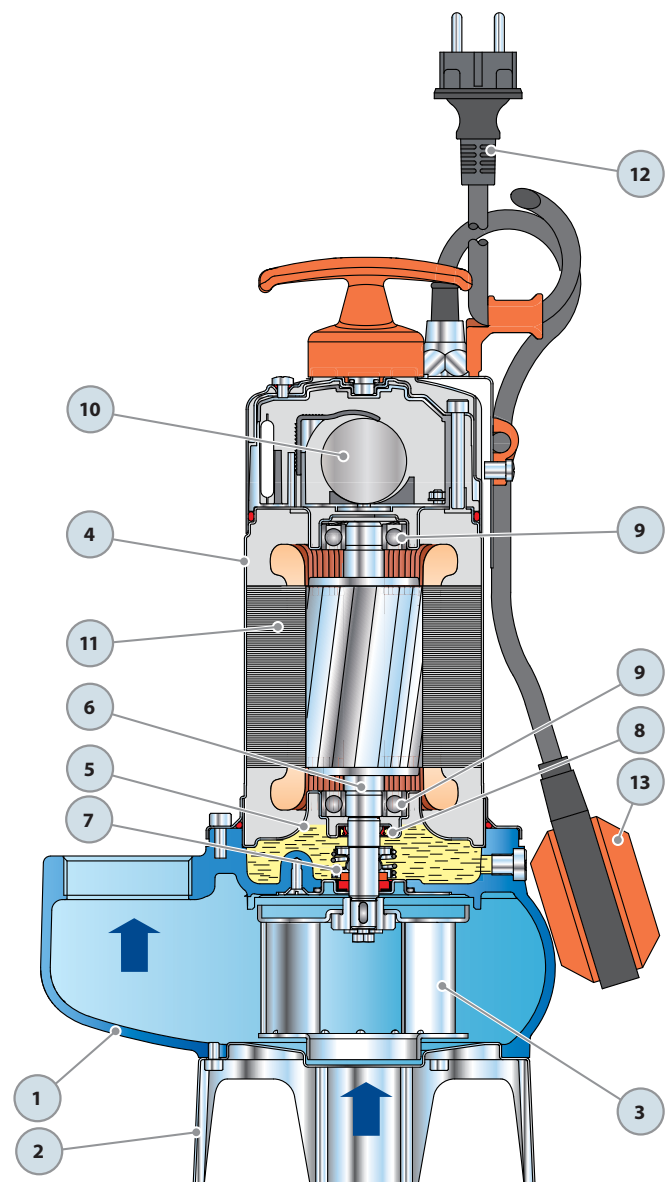

DIMENSIONS AND WEIGHT

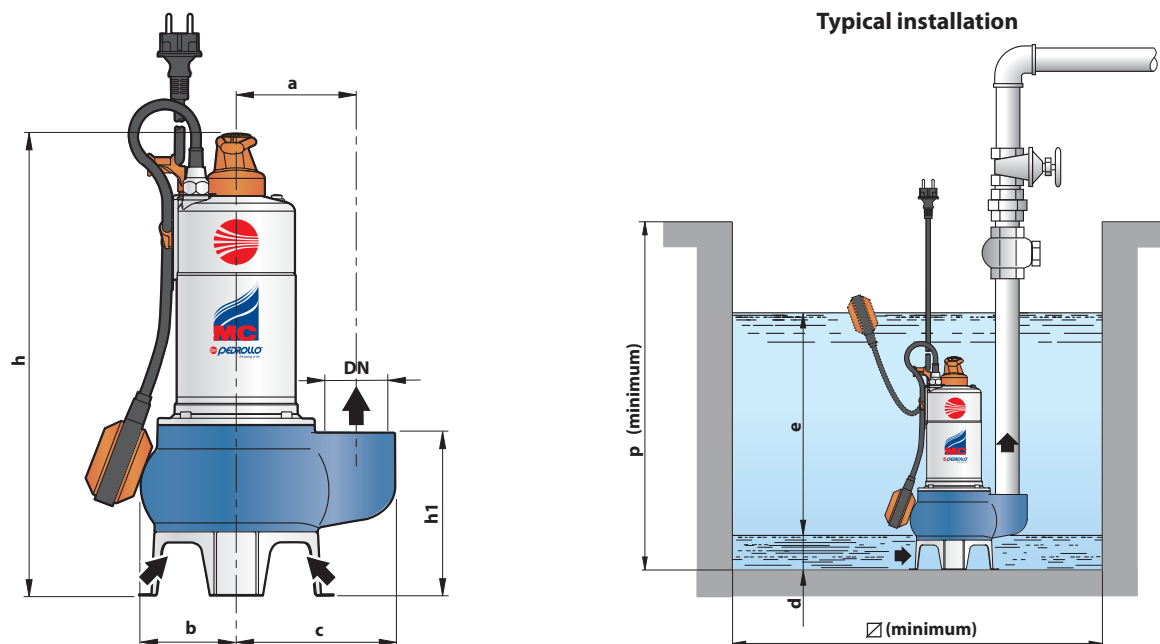

MODEL		PORT DN	solids passage	DIMENSIONS mm									kg	
Single-phase	Three-phase			a	b	c	h	h1	d	e	p	∅	1~	3~
MCm 10/50	MC 10/50	2"	∅ 50 mm	110	92	150	437	153	60	variable	500	500	14.1	12.9
MCm 12/50	MC 12/50			115	97	157	458	159					17.0	15.8

ABSORPTION

MODEL	VOLTAGE (single-phase)		
	230 V	240 V	110 V
MCm 10/50	5.2 A	5.2 A	11.7 A
MCm 12/50	8.5 A	8.5 A	-

MODEL	VOLTAGE (three-phase)			
	230 V	400 V	240 V	415 V
MC 10/50	3.6 A	2.1 A	3.6 A	2.1 A
MC 12/50	6.1 A	3.5 A	6.1 A	3.5 A

PALLETIZATION

MODEL		GROUPAGE			CONTAINER				
Single-phase	Three-phase	n° pumps	H (mm)	kg		n° pumps	H (mm)	kg	
				1~	3~			1~	3~
MCm 10/50	MC 10/50	60	1520	865	791	80	1980	1148	1049
MCm 12/50	MC 12/50	45	1574	784	730	60	2052	1039	968

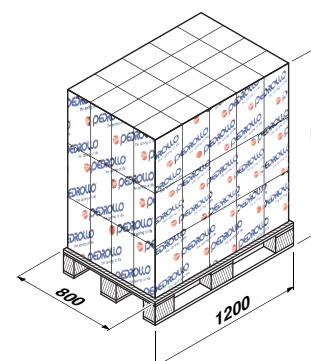

VX-F "VORTEX"

Pump with flanged port

⇒ for sewage water



PERFORMANCE RANGE

- Flow rate up to **400 l/min** (24 m³/h)
- Head up to **7.5 m**

APPLICATION LIMITS

- **5 m** maximum immersion depth
- Maximum liquid temperature **+40 °C**
- Passage of suspended solids up to **Ø 50 mm**
- **300 mm** minimum immersion depth for continuous service

CONSTRUCTION AND SAFETY STANDARDS

- Complete with **5 m** long power cable
 - Float switch for single-phase versions
- ⇒ The "CF" delivery elbow is available separately

EN 60335-1
IEC 60335-1
CEI 61-150

EN 60034-1
IEC 60034-1
CEI 2-3



CERTIFICATIONS



INSTALLATION AND USE

Suitable for use in domestic, civil and industrial applications where the water, such as **groundwater, surface water and sewage water**, contains suspended solids up to Ø 50 mm.

They are suitable for use in applications such as for draining flooded areas such as cellars, underground car parks, car washes, for emptying cesspools and for sewage disposal.

These pumps distinguish themselves for their reliability, which can be best appreciated under automatic operating conditions in fixed installations.

PATENTS - TRADE MARKS - MODELS

- Patent pending n° BO2008A000494, BO2008A000496

OPTIONALS AVAILABLE ON REQUEST

- "CF" Delivery kit - discharge elbow with bolts and seal.
- Pumps with a **10 m** long power cable
 - ⇒ N.B. Standard EN 60335-2-41 states that the power cable must be 10 m long for outdoor applications
- Single-phase pumps without float switch
- Other voltages or 60 Hz frequency

GUARANTEE

1 year subject to terms and conditions

CHARACTERISTIC CURVES AND PERFORMANCE DATA

50 Hz n= 2900 1/min

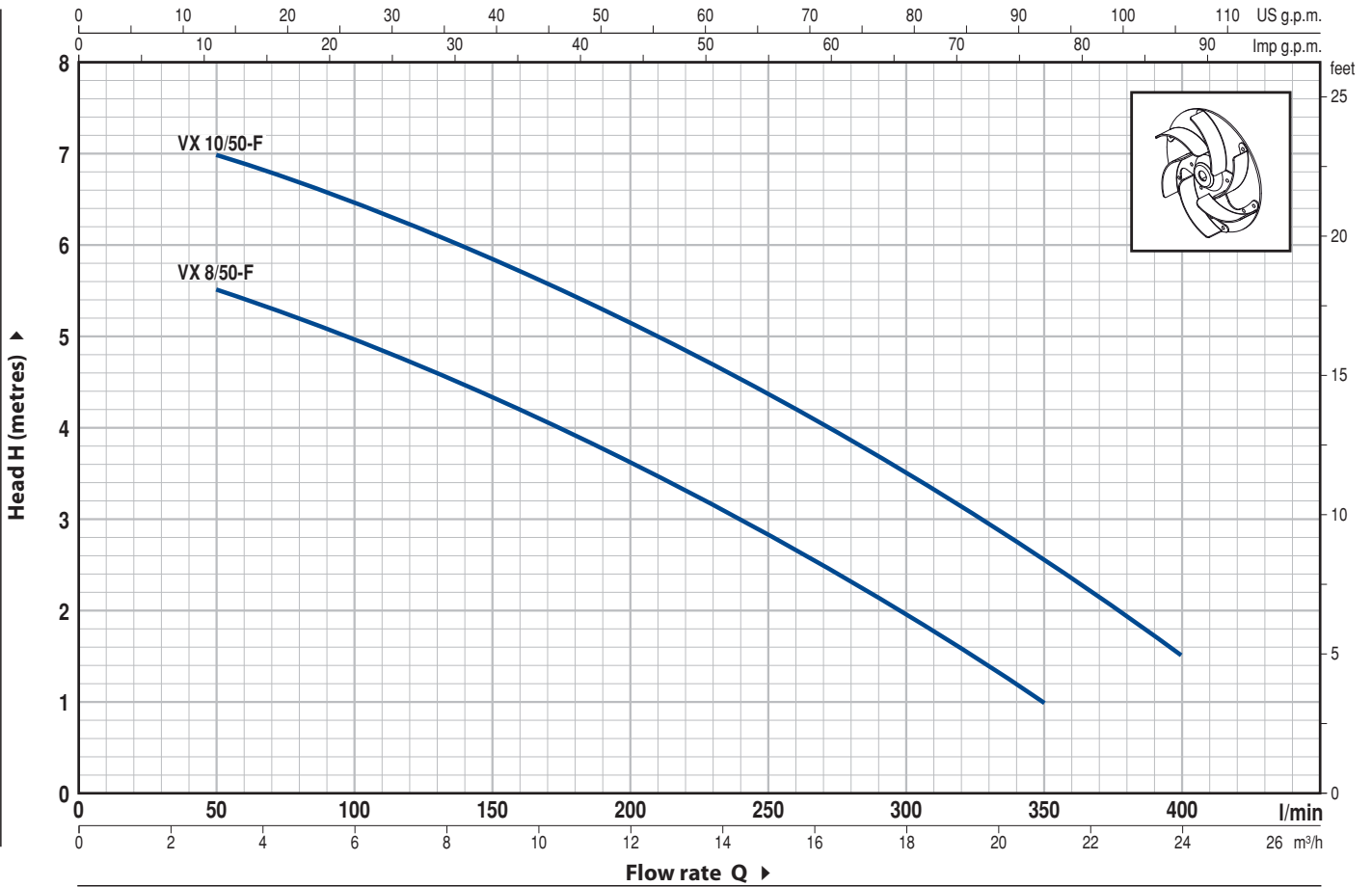

MODEL		POWER		Q	Flow rate									
Single-phase	Three-phase	kW	HP		0	3	6	9	12	15	18	21	24	
VXm 8/50-F	-	0.55	0.75	H metres	6	5.5	5	4.4	3.6	2.8	2	1	400	
VXm 10/50-F	VX 10/50-F	0.75	1		7.5	7	6.5	5.8	5	4	3.2	2.4	1.5	

Q = Flow rate H = Total manometric head

Tolerance of characteristic curves in compliance with EN ISO 9906 App. A.

VX-F "VORTEX"

POS.	COMPONENT	CONSTRUCTION CHARACTERISTICS			
1	PUMP BODY	Cast iron, complete with flanged port			
2	BASE	Stainless steel AISI 304			
3	IMPELLER	Stainless steel AISI 304 VORTEX type			
4	MOTOR CASING	Stainless steel AISI 304			
5	MOTOR CASING PLATE	Stainless steel AISI 304			
6	MOTOR SHAFT	Stainless steel EN 10088-3 - 1.4104			
7	SHAFT WITH DOUBLE SEAL AND OIL CHAMBER				
	<i>Seal</i>	<i>Shaft</i>	<i>Materials</i>		
	<i>Model</i>	<i>Diameter</i>	<i>Stationary ring</i>	<i>Rotational ring</i>	<i>Elastomer</i>
	MG1-14 SIC	Ø 14 mm	Ceramic	Silicon carbide	NBR
8	LIP SEAL	Ø 15 x Ø 24 x H 5 mm			
9	BEARINGS	6203 ZZ / 6203 ZZ			
10	CAPACITOR				
	<i>Pump</i>	<i>Capacitance</i>			
	<i>Single-phase</i>	<i>(230 V or 240 V)</i>	<i>(110 V)</i>		
	VXm 8/50-F	20 µF 450 VL	30 µF 250 VL		
	VXm 10/50-F				
11	ELECTRIC MOTOR				
	<ul style="list-style-type: none"> – Single-phase 230 V - 50 Hz with thermal overload protector built-in to the winding – Three-phase 400 V - 50 Hz – Insulation: F class – Protection: IP 68 				
12	POWER CABLE				
	5 metre long "H07 RN-F" cable (with Schuko plug on single-phase versions only)				
13	FLOAT SWITCH				
	(only for single-phase versions)				
14	"CF" CURVED DELIVERY KIT				
	Complete with: <ul style="list-style-type: none"> – cast iron flanged curved delivery attachment – seal – stainless steel screws 				

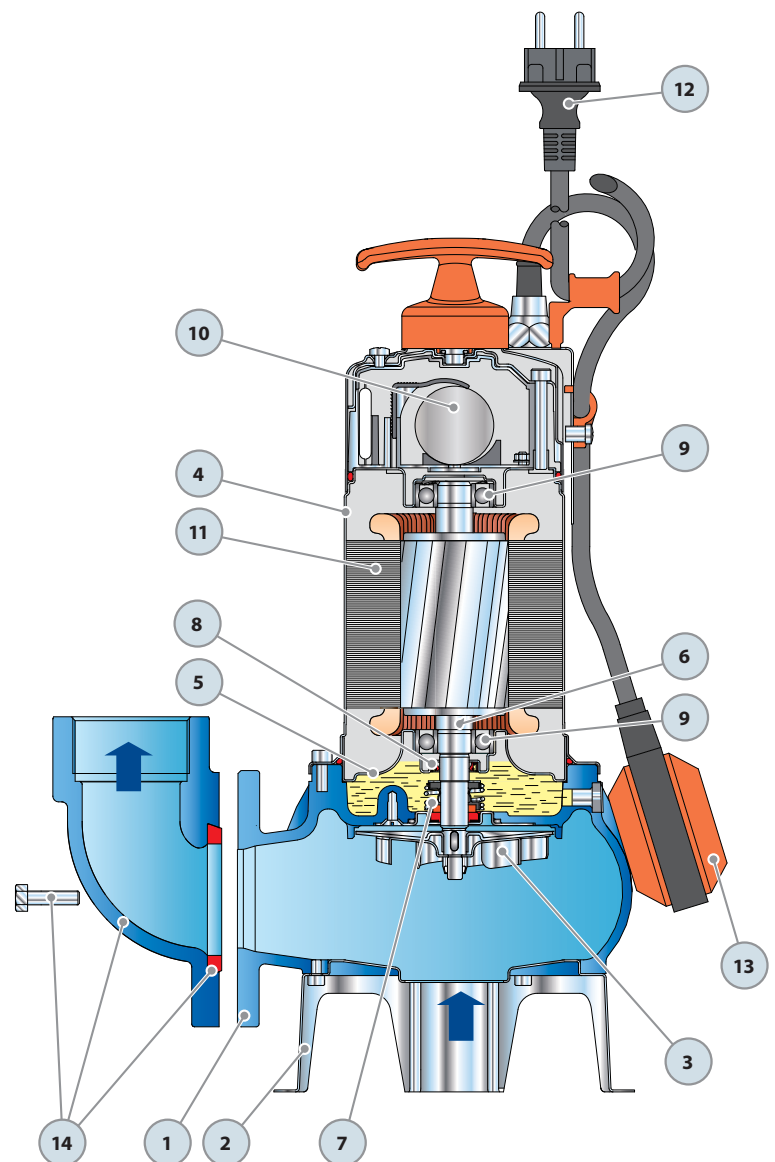

DIMENSIONS AND WEIGHT

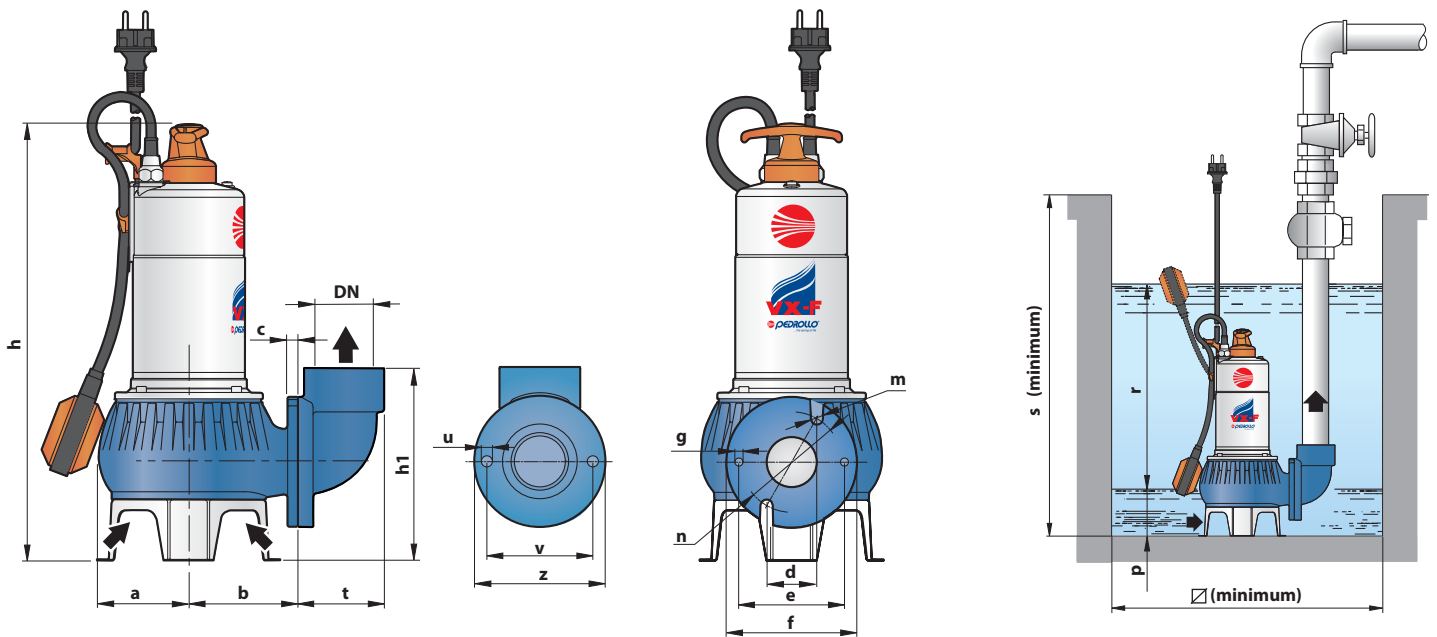

MODEL		solids passage	DIMENSIONS mm														kg	
Single-phase	Three-phase		a	b	c	d	e	f	g	h	m	n	p	r	s	□	1~	3~
VXm 8/50-F	-	Ø 50 mm	90	110	11	50	105	130	M10	437	12	100	60	variable	500	500	13.4	-
VXm 10/50-F	VX 10/50-F		14.6	13.3														

MODEL	PORT	DIMENSIONS mm						kg
Curved delivery	DN	h1	t	u	v	z		
CF	2"	192	85	11	105	130	2.4	

ABSORPTION

MODEL	VOLTAGE (single-phase)		
Single-phase	230 V	240 V	110 V
VXm 8/50-F	3.5 A	3.5 A	8.0 A
VXm 10/50-F	5.0 A	5.0 A	11.5 A

MODEL	VOLTAGE (three-phase)			
Three-phase	230 V	400 V	240 V	415 V
VX 10/50-F	3.6 A	2.1 A	3.6 A	2.1 A

PALLETIZATION

MODEL		GROUPAGE				CONTAINER			
Single-phase	Three-phase	n° pumps	H (mm)	kg		n° pumps	H (mm)	kg	
				1~	3~			1~	3~
VXm 8/50-F	-	60	1520	821	-	80	1980	1089	-
VXm 10/50-F	VX 10/50-F	60	1520	893	815	80	1980	1185	1081

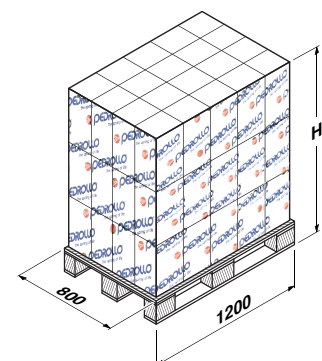

MC-F "DOUBLE-CHANNEL"

Pump with flanged port

⇒ for sewage water



PERFORMANCE RANGE

- Flow rate up to **500 l/min** (30 m³/h)
- Head up to **12 m**

APPLICATION LIMITS

- **5 m** maximum immersion depth
- Maximum liquid temperature **+40 °C**
- Passage of suspended solids up to **Ø 50 mm**
- **300 mm** minimum immersion depth for continuous service

CONSTRUCTION AND SAFETY STANDARDS

- Complete with **5 m** long power cable
 - Float switch for single-phase versions
- ⇒ **The "CF" delivery elbow is available separately**

EN 60335-1
IEC 60335-1
CEI 61-150

EN 60034-1
IEC 60034-1
CEI 2-3



CERTIFICATIONS



INSTALLATION AND USE

MC-F submersible pumps are suitable for draining **dirty water and sewage** in domestic and civil applications. They come equipped with a **DOUBLE-CHANNEL** stainless steel impeller and are capable of pumping liquids containing short fibred suspended solids up to Ø 50 mm.

They are ideal for pumping sewage water, waste water, surface water and water mixed with mud in locations such as holiday homes and detached homes.

These pumps distinguish themselves for their reliability, which can be best appreciated under automatic operating conditions in fixed installations.

PATENTS - TRADE MARKS - MODELS

- Patent pending n° BO2008A000494, BO2008A000496

OPTIONALS AVAILABLE ON REQUEST

- **"CF" Delivery kit - discharge elbow with bolts and seal.**
- Pumps with a **10 m** long power cable
 - ⇒ N.B. Standard EN 60335-2-41 states that the power cable must be 10 m long for outdoor applications
- Single-phase pumps without float switch
- Other voltages or 60 Hz frequency

GUARANTEE

1 year subject to terms and conditions

CHARACTERISTIC CURVES AND PERFORMANCE DATA

50 Hz n= 2900 1/min

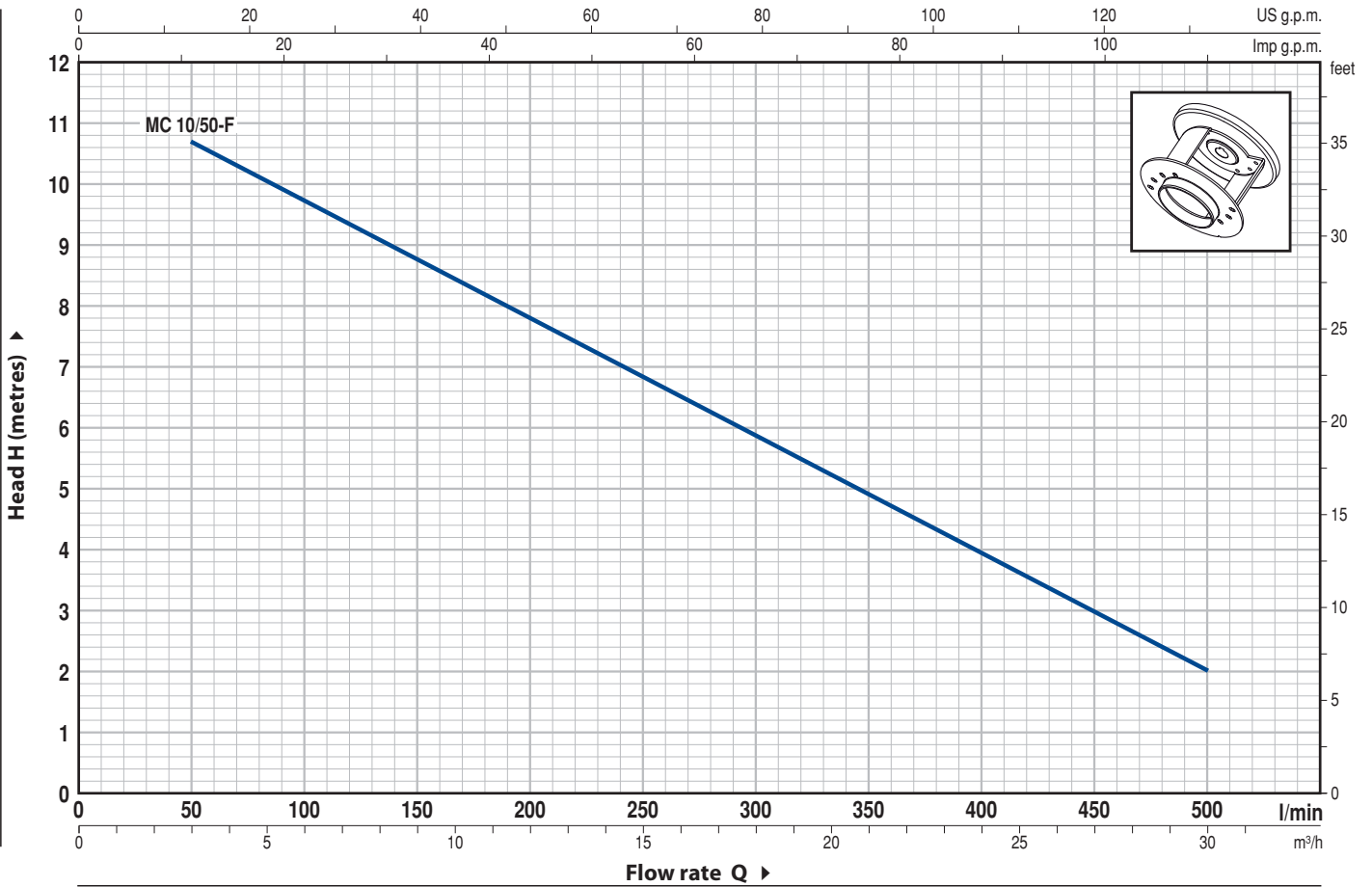

MODEL		POWER		Q	Flow rate												
Single-phase	Three-phase	kW	HP		m ³ /h	0	3	6	9	12	15	18	21	24	27	30	
MCm 10/50-F	MC 10/50-F	0.75	1	H metres	12	10.7	9.7	8.7	7.8	6.8	5.9	5	4	3	2		

Q = Flow rate H = Total manometric head

Tolerance of characteristic curves in compliance with EN ISO 9906 App. A.

MC-F "DOUBLE-CHANNEL"

POS.	COMPONENT	CONSTRUCTION CHARACTERISTICS
1	PUMP BODY	Cast iron, complete with flanged port
2	BASE	Stainless steel aisi 304
3	IMPELLER	Stainless steel AISI 304 DOUBLE-CHANNEL type
4	MOTOR CASING	Stainless steel AISI 304
5	MOTOR CASING PLATE	Stainless steel AISI 304
6	MOTOR SHAFT	Stainless steel EN 10088-3 - 1.4104
7	SHAFT WITH DOUBLE SEAL AND OIL CHAMBER	
	<i>Seal</i>	<i>Shaft</i>
	<i>Model</i>	<i>Diameter</i>
	MG1-14 SIC	Ø 14 mm
		<i>Stationary ring</i>
		Ceramic
		<i>Rotational ring</i>
		Silicon carbide
		<i>Elastomer</i>
		NBR
8	LIP SEAL	Ø 15 x Ø 24 x H 5 mm
9	BEARINGS	6203 ZZ / 6203 ZZ
10	CAPACITOR	
	<i>Capacitance</i>	
	<i>(230 V or 240 V)</i>	<i>(110 V)</i>
	20 µF 450 VL	30 µF 250 VL
11	ELECTRIC MOTOR	
	<ul style="list-style-type: none"> – Single-phase 230 V - 50 Hz with thermal overload protector built-in to the winding – Three-phase 400 V - 50 Hz – Insulation: F class – Protection: IP 68 	
12	POWER CABLE	
	5 metre long "H07 RN-F" cable (with Schuko plug on single-phase versions only)	
13	FLOAT SWITCH	
	(only for single-phase versions)	
14	"CF" CURVED DELIVERY KIT	
	Complete with: <ul style="list-style-type: none"> – cast iron flanged curved delivery attachment – seal – stainless steel screws 	

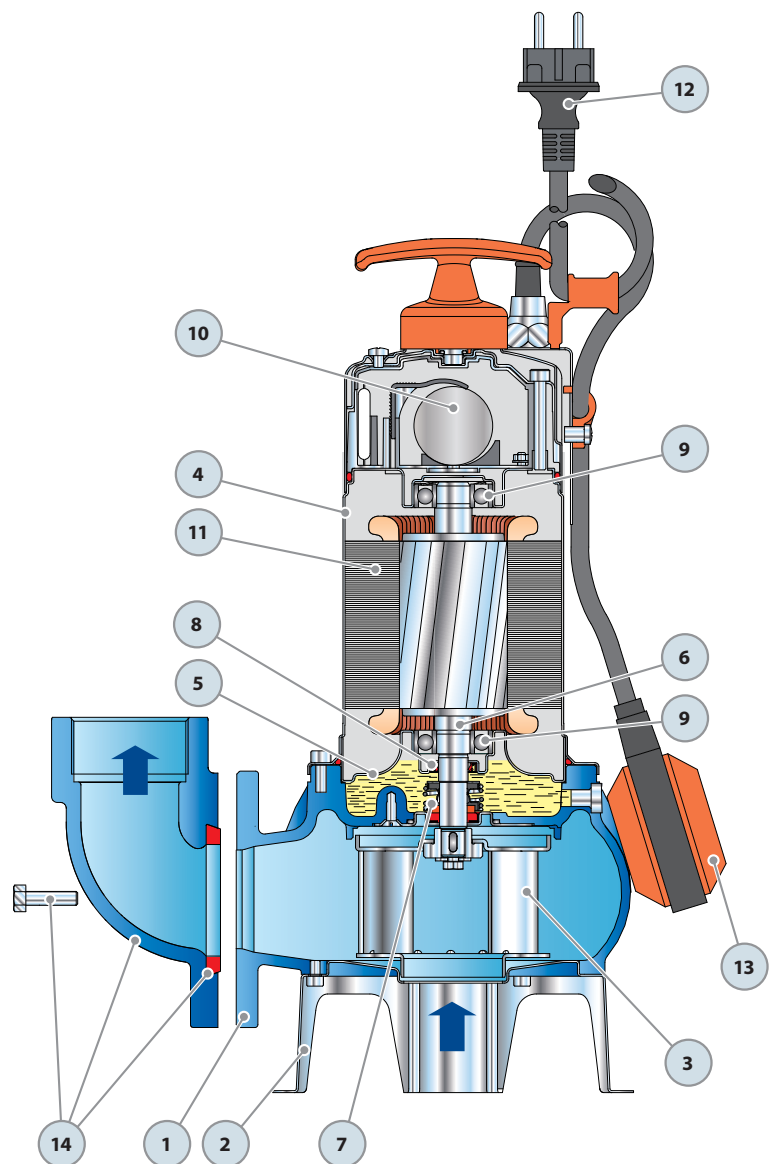

DIMENSIONS AND WEIGHT

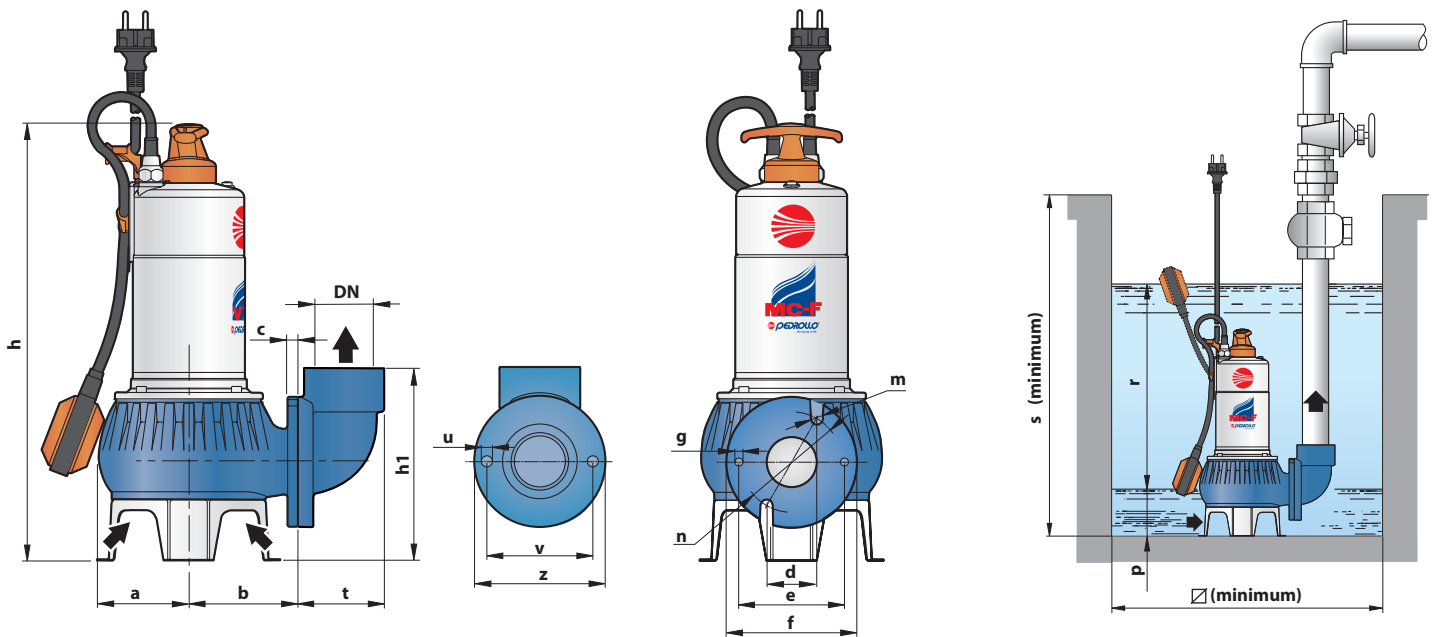

MODEL		solids passage	DIMENSIONS mm														kg	
Single-phase	Three-phase		a	b	c	d	e	f	g	h	m	n	p	r	s	□	1~	3~
MCm 10/50-F	MC 10/50-F	Ø 50 mm	90	110	11	50	105	130	M10	437	12	100	60	variable	500	500	14.5	13.2

MODEL		PORT DN	DIMENSIONS mm					kg
Curved delivery			h1	t	u	v	z	
CF		2"	192	85	11	105	130	2.4

ABSORPTION

MODEL	VOLTAGE (single-phase)		
	Single-phase	230 V	240 V
MCm 10/50-F	5.2 A	5.2 A	11.7 A

MODEL	VOLTAGE (three-phase)			
	Three-phase	230 V	400 V	240 V
MC 10/50-F	3.6 A	2.1 A	3.6 A	2.1 A

PALLETIZATION

MODEL		GROUPAGE				CONTAINER			
Single-phase	Three-phase	n° pumps	H (mm)	kg		n° pumps	H (mm)	kg	
				1~	3~			1~	3~
MCm 10/50-F	MC 10/50-F	60	1520	887	809	80	1980	1177	1073

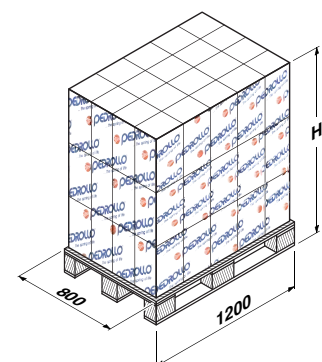

VXC "VORTEX"

Submersible pumps

▣▣▣▣ for sewage water



PERFORMANCE RANGE

- Flow rate up to **500 l/min** (30 m³/h)
- Head up to **15 m**

APPLICATION LIMITS

- **10 m** maximum immersion depth
- Maximum liquid temperature **+40 °C**
- Solids passage:
 - up to **Ø 40 mm** for VXC 8-10-15/35
 - up to **Ø 50 mm** for VXC 8-10-15/45
- Minimum immersion depth for continuous service:
 - **290 mm** for VXC 8-10-15/35
 - **320 mm** for VXC 8-10-15/45

CONSTRUCTION AND SAFETY STANDARDS

- Complete with **10 m** long power cable
- Float switch for single-phase versions

EN 60034-1
IEC 60034-1
CEI 2-3



CERTIFICATIONS



INSTALLATION AND USE

VXC series pumps, made from heavy gauge cast iron offering exceptional sturdiness and abrasion resistance, come equipped with a VORTEX impeller and are therefore suitable for draining **waste water containing suspended solids, sewage and water mixed with mud.**

PATENTS - TRADE MARKS - MODELS

- Registered Community Design n° 342159-0017

OPTIONALS AVAILABLE ON REQUEST

- Single-phase pumps without float switch
- Other voltages or 60 Hz frequency

GUARANTEE

1 year subject to terms and conditions

CHARACTERISTIC CURVES AND PERFORMANCE DATA

50 Hz n= 2900 1/min

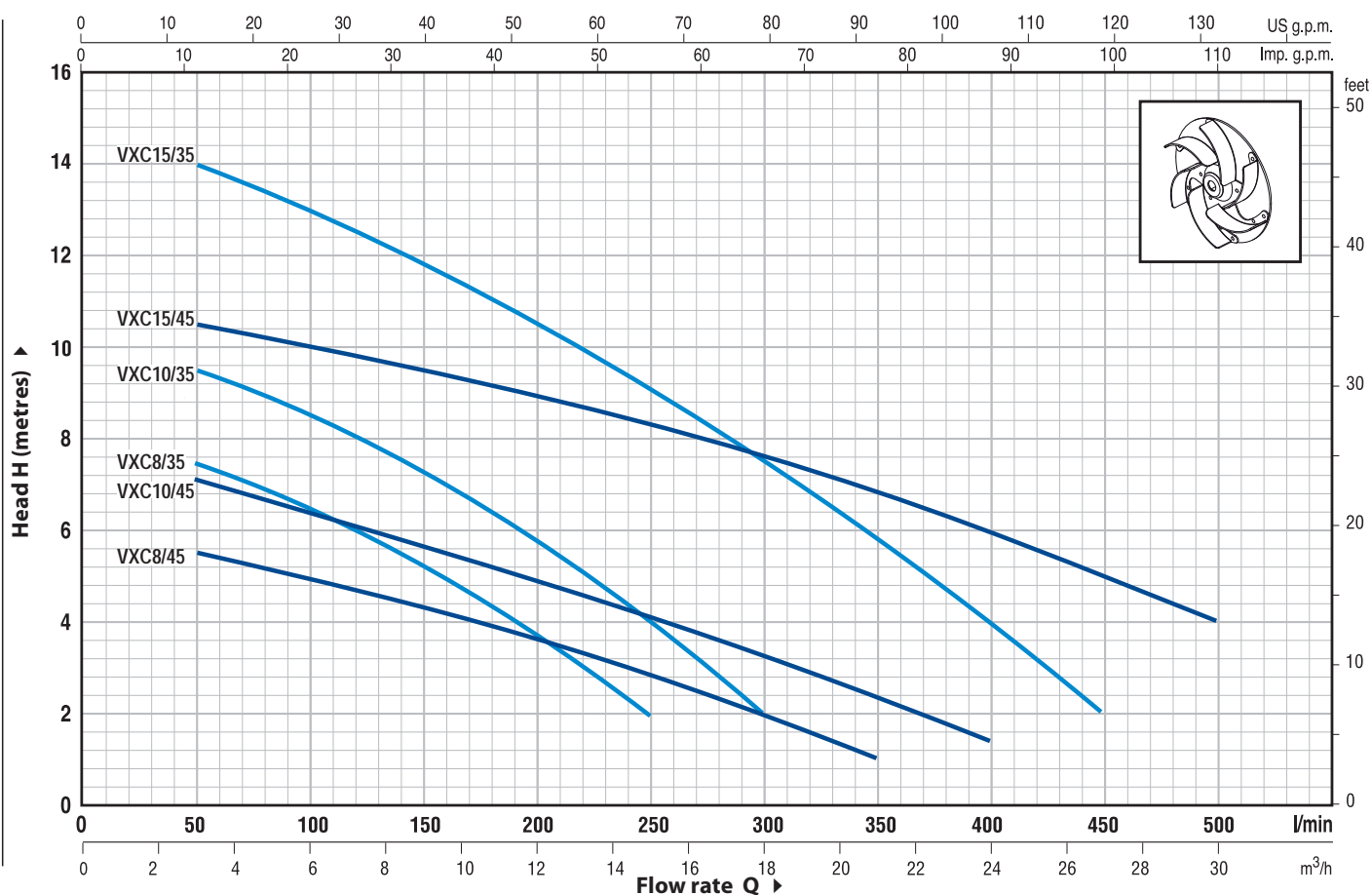

MODEL		POWER		Q	Flow rate														
Single-phase	Three-phase	kW	HP		m³/h	0	3	6	9	12	15	18	21	24	27	30			
				l/min	0	50	100	150	200	250	300	350	400	450	500				
VXCm 8/35	–	0.55	0.75	H metres	8.4	7.5	6.5	5.2	3.7	2									
VXCm 10/35	VXC 10/35	0.75	1		10	9.5	8.5	7.2	5.8	4	2								
VXCm 15/35	VXC 15/35	1.1	1.5		15	14	13	11.8	10.5	9	7.5	6	4	2					
VXCm 8/45	–	0.55	0.75		6	5.5	5	4.4	3.6	2.8	2	1							
VXCm 10/45	VXC 10/45	0.75	1		7.5	7	6.5	5.8	5	4	3.2	2.4	1.5						
VXCm 15/45	VXC 15/45	1.1	1.5		11	10.5	10	9.5	9	8.3	7.5	6.8	6	5	4				

Q = Flow rate H = Total manometric head

Tolerance of characteristic curves in compliance with EN ISO 9906 App. A.

POS.	COMPONENT	CONSTRUCTION CHARACTERISTICS			
1	PUMP BODY	Cast iron, with threaded port in compliance with ISO 228/1			
2	BASE	Stainless steel AISI 304			
3	IMPELLER	Stainless steel AISI 304 VORTEX type			
4	MOTOR CASING	Cast iron			
5	MOTOR CASING PLATE	Stainless steel AISI 304			
6	MOTOR SHAFT	Stainless steel EN 10088-3 - 1.4104			
7	SHAFT WITH DOUBLE SEAL AND OIL CHAMBER				
	<i>Seal</i>	<i>Shaft</i>	<i>Materials</i>		
	<i>Model</i>	<i>Diameter</i>	<i>Stationary ring</i>	<i>Rotational ring</i>	<i>Elastomer</i>
	MG1-14 SIC	Ø 14 mm	Ceramic	Silicon carbide	NBR
8	LIP SEAL	Ø 15 x Ø 24 x H 5 mm for VXC 8-10/35-45 Ø 16 x Ø 24 x H 5 mm for VXC 15/35-45			
9	BEARINGS	6203 ZZ / 6203 ZZ			
10	CAPACITOR				
	<i>Pump</i>	<i>Capacitance</i>			
	<i>Single-phase</i>	<i>(230 V or 240 V)</i>	<i>(110 V)</i>		
	VXCm 8/35	20 µF 450 VL	30 µF 250 VL		
	VXCm 8/45				
	VXCm 10/35				
	VXCm 10/45	25 µF 450 VL	-		
	VXCm 15/35				
	VXCm 15/45				
11	ELECTRIC MOTOR				
	<ul style="list-style-type: none"> - Single-phase 230 V - 50 Hz with thermal overload protector built-in to the winding - Three-phase 400 V - 50 Hz - Insulation: F class - Protection: IP 68 				
12	POWER CABLE				
	10 metre long "H07 RN-F" cable (with Schuko plug on single-phase versions only)				
13	FLOAT SWITCH				
	(only for single-phase versions)				

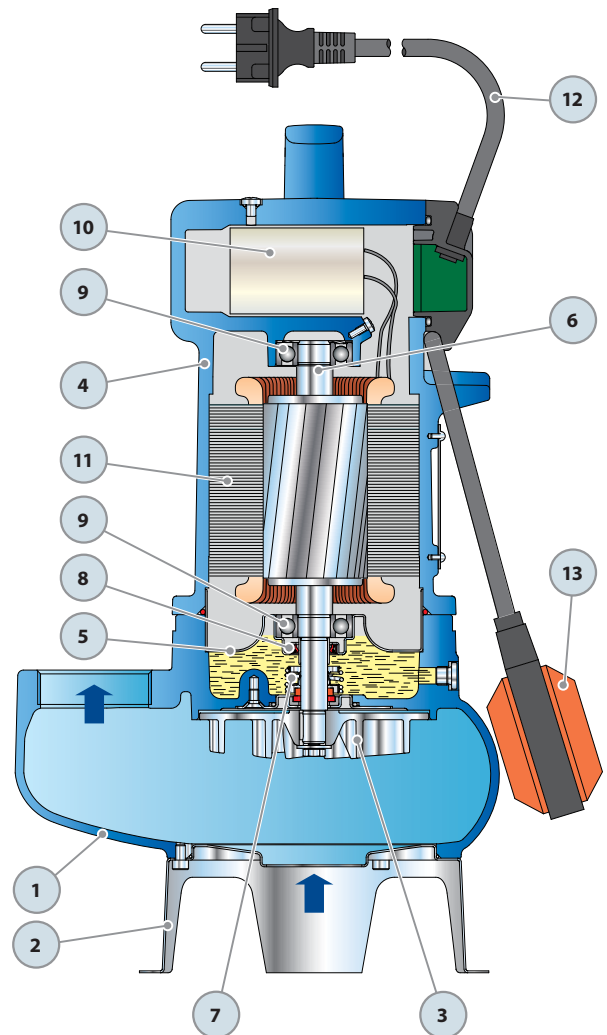

DIMENSIONS AND WEIGHT

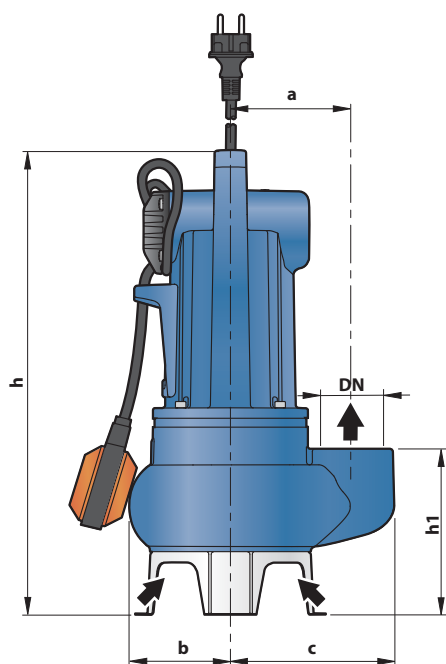

Typical installation

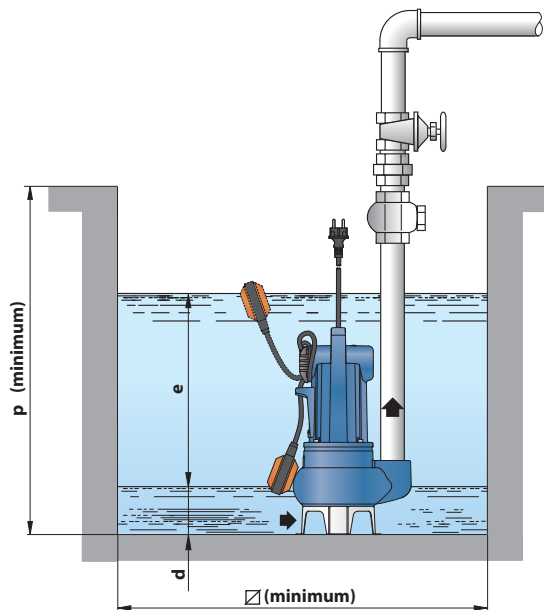

MODEL		PORT DN	solids passage	DIMENSIONS mm									kg	
Single-phase	Three-phase			a	b	c	h	h1	d	e	p	Ø	1~	3~
VXCm 8/35	–	1½"	Ø 40 mm	105	92	136	385	125	50	variable	500	500	19.8	–
VXCm 10/35	VXC 10/35					143	406	130					20.0	18.3
VXCm 15/35	VXC 15/35			150	414	153	60	22.8	24.4					
VXCm 8/45	–	2"	Ø 50 mm	110	97	150	414	153	60	variable	500	500	20.5	–
VXCm 10/45	VXC 10/45					157	435	159					20.5	18.7
VXCm 15/45	VXC 15/45			115	157	435	159	60	23.5				21.1	

ABSORPTION

MODEL	VOLTAGE (single-phase)		
	230 V	240 V	110 V
Single-phase	230 V	240 V	110 V
VXCm 8/35	3.3 A	3.3 A	7.6 A
VXCm 10/35	5.0 A	5 A	11.5 A
VXCm 15/35	6.7 A	6.7 A	–
VXCm 8/45	3.5 A	3.5 A	8.0 A
VXCm 10/45	5.0 A	5.0 A	11.5 A
VXCm 15/45	7.1 A	7.1 A	–

MODEL	VOLTAGE (three-phase)			
	230 V	400 V	240 V	415 V
Three-phase	230 V	400 V	240 V	415 V
VXC 10/35	3.6 A	2.1 A	3.6 A	2.1 A
VXC 15/35	5.4 A	3.1 A	5.4 A	3.1 A
VXC 10/45	6.6 A	2.1 A	6.6 A	2.1 A
VXC 15/45	5.4 A	3.1 A	5.4 A	3.1 A

PALLETIZATION

MODEL		GROUPAGE				CONTAINER			
		n° pumps	H (mm)	kg		n° pumps	H (mm)	kg	
Single-phase	Three-phase			1~	3~			1~	3~
VXCm 8/35	–	45	1400	908	–	60	1820	1205	–
VXCm 10/35	VXC 10/35	45	1400	917	838	60	1820	1217	1112
VXCm 15/35	VXC 15/35	45	1574	1042	935	60	2052	1384	1241
VXCm 8/45	–	45	1400	942	–	60	1820	1250	–
VXCm 10/45	VXC 10/45	45	1400	940	859	60	1820	1247	1140
VXCm 15/45	VXC 15/45	45	1574	1076	967	60	2052	1429	1283

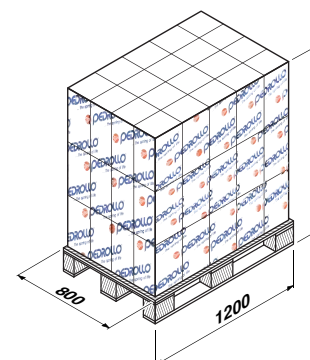

VXC "VORTEX"

Submersible pumps

for sewage water



PERFORMANCE RANGE

- Flow rate up to **1200 l/min** (72 m³/h)
- Head up to **16 m**

APPLICATION LIMITS

- **10 m** maximum immersion depth
- Maximum liquid temperature **+40 °C**
- Solids passage:
 - up to **Ø 50 mm** for VXC 15-20-30/50
 - up to **Ø 70 mm** for VXC 15-20-30/70
- Minimum immersion depth for continuous service:
 - **380 mm** for VXC 15-20-30/50
 - **430 mm** for VXC 15-20-30/70

CONSTRUCTION AND SAFETY STANDARDS

- Complete with **10 m** long power cable
- Float switch for single-phase versions

EN 60034-1
IEC 60034-1
CEI 2-3



CERTIFICATIONS



INSTALLATION AND USE

VXC series pumps, made from heavy gauge cast iron offering exceptional sturdiness, abrasion resistance and durability, come equipped with a VORTEX impeller and are therefore suitable for draining **waste water, sewage, water mixed with mud and sludge**. They are ideal for use in sewage installations, tunnels, excavations, canals and underground car parks, etc.

PATENTS - TRADE MARKS - MODELS

- Registered Community Design n° 342159-0017

OPTIONALS AVAILABLE ON REQUEST

- QES control box for three-phase pumps
- Three-phase dual voltage pumps:
 - 230/400 V or
 - 400/690 V
- Single-phase pumps without float switch
- Other voltages or 60 Hz frequency

GUARANTEE

1 year subject to terms and conditions

For the following versions the built-in thermal overload protector must be connected to the control box in order for the guarantee to be considered valid:

single-phase
– VXCm 30/50 - HP 3
– VXCm 30/70 - HP 3

three-phase
– VXC 15-20-30/50 - HP 1.5-2-3
– VXC 15-20-30/70 - HP 1.5-2-3

CHARACTERISTIC CURVES AND PERFORMANCE DATA

50 Hz n= 2900 1/min

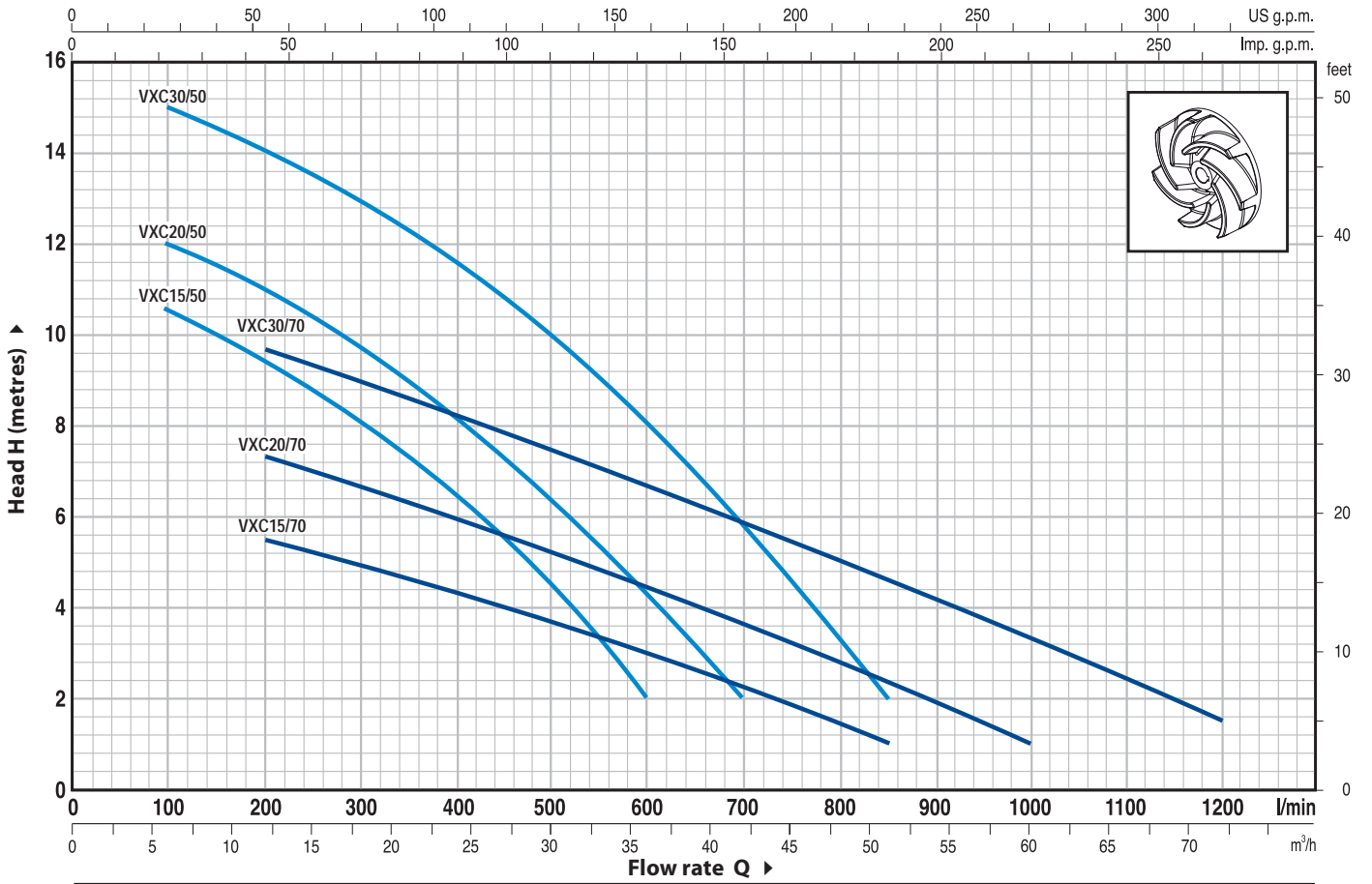

MODEL		POWER		Q	Flow rate																
Single-phase	Three-phase	kW	HP		m³/h	0	6	12	18	21	24	30	36	42	48	51	54	60	66	72	
				l/min	0	100	200	300	350	400	500	600	700	800	850	900	1000	1100	1200		
VXCm 15/50	VXC 15/50	1.1	1.5	H metres	11.5	10.5	9.5	8.2	7.2	6.5	4.5	2									
VXCm 20/50	VXC 20/50	1.5	2		13	12	11	9.5	9	8	6.5	4.5	2								
VXCm 30/50	VXC 30/50	2.2	3		16	15	14	13	12.3	11.5	10	8	5.9	3.3	2						
VXCm 15/70	VXC 15/70	1.1	1.5		6.5	-	5.5	5	4.7	4.4	3.7	3	2.2	1.5	1						
VXCm 20/70	VXC 20/70	1.5	2		8.5	-	7.4	6.7	6.3	6	5.2	4.5	3.6	2.8	2.4	2	1				
VXCm 30/70	VXC 30/70	2.2	3		11	-	9.7	9	8.6	8.2	7.5	6.7	5.8	5	4.6	4.2	3.3	2.5	1.5		

Q = Flow rate H = Total manometric head

Tolerance of characteristic curves in compliance with EN ISO 9906 App. A.

POS.	COMPONENT	CONSTRUCTION CHARACTERISTICS			
1	PUMP BODY	Cast iron, with threaded port in compliance with ISO 228/1			
2	BASE	Stainless steel AISI 304			
3	IMPELLER	Cast iron VORTEX type			
4	MOTOR CASING	Cast iron			
5	MOTOR CASING PLATE	Cast iron			
6	MOTOR SHAFT	Stainless steel AISI 431			
7	SHAFT WITH DOUBLE SEAL AND OIL CHAMBER				
	<i>Seal</i>	<i>Shaft</i>	<i>Materials</i>		
	<i>Model</i>	<i>Diameter</i>	<i>Stationary ring</i>	<i>Rotational ring</i>	<i>Elastomer</i>
	FN-20 DV	Ø 20 mm	Widia	Silicon carbide	NBR
8	LIP SEAL	Ø 20 x Ø 30 x H 7 mm			
9	BEARINGS	6304 ZZ - C3 / 6304 ZZ - C3			
10	CAPACITOR				
	<i>Pump</i>	<i>Capacitance</i>			
	<i>Single-phase</i>	<i>(230 V or 240 V)</i>			
	VXCm 15/50	31.5 µF 450 VL			
	VXCm 15/70	50 µF 450 VL			
	VXCm 20/50	50 µF 450 VL			
	VXCm 20/70	60 µF 450 VL			
	VXCm 30/50	60 µF 450 VL			
	VXCm 30/70	60 µF 450 VL			
11	ELECTRIC MOTOR				
	VXCm 15-20: single-phase 230 V - 50 Hz with thermal overload protector built-in to the winding				
	⇒ VXCm 30: single-phase 230 V - 50 Hz with thermal overload protector built-in to the winding to be connected to the control box.				
	⇒ VXC: three-phase 400 V - 50 Hz. with thermal overload protector built-in to the winding to be connected to the control box.				
	– Insulation: F class.				
	– Protection: IP 68.				
12	POWER CABLE				
	10 metre long "H07 RN-F" cable				
13	CONTROL BOX for VXCm 15-20				
	(only for single-phase versions)				
	Complete with capacitor and manual reset motor protector				
14	CONTROL BOX for VXCm 30				
	(only for single-phase versions)				
	QES 300 MONO series				
15	FLOAT SWITCH				
	(only for single-phase versions)				

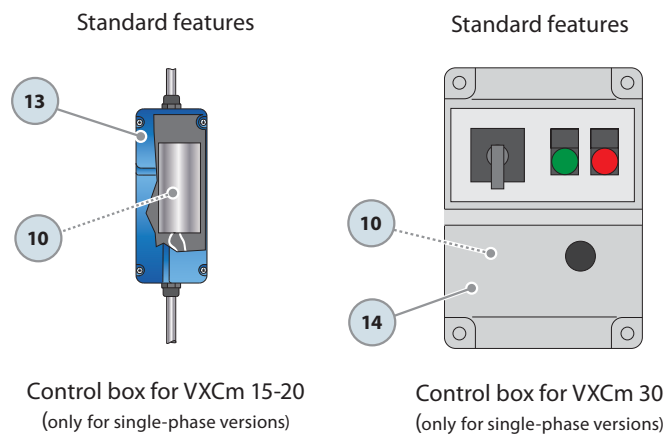
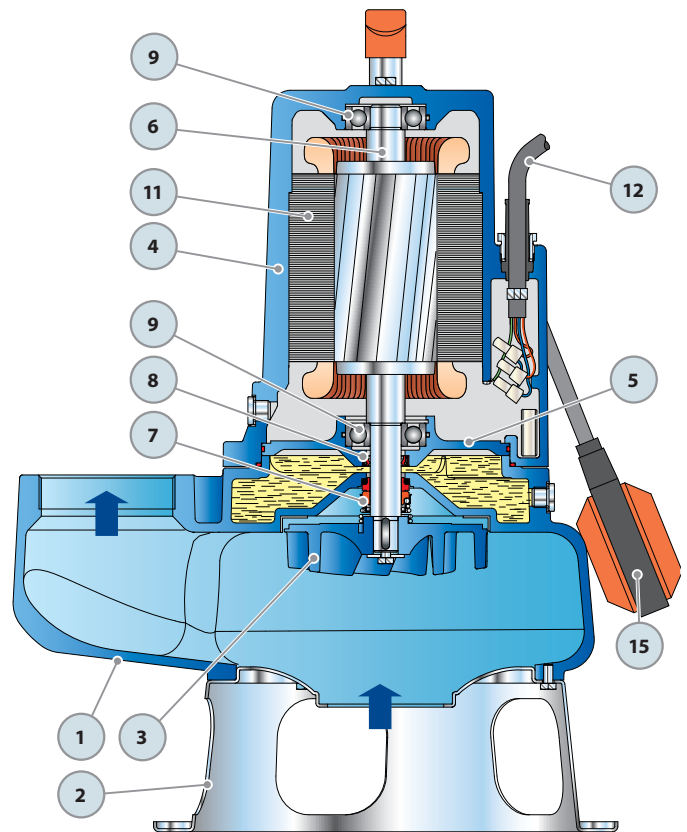

Control box for VXCm 15-20 (only for single-phase versions)

Control box for VXCm 30 (only for single-phase versions)

DIMENSIONS AND WEIGHT

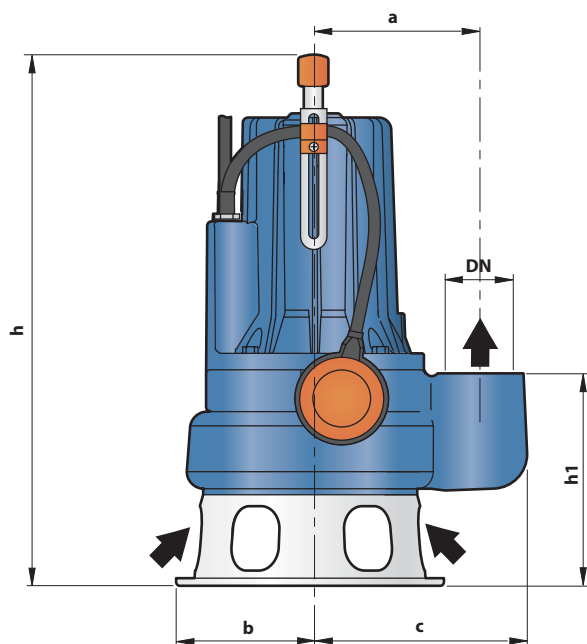

Typical installation

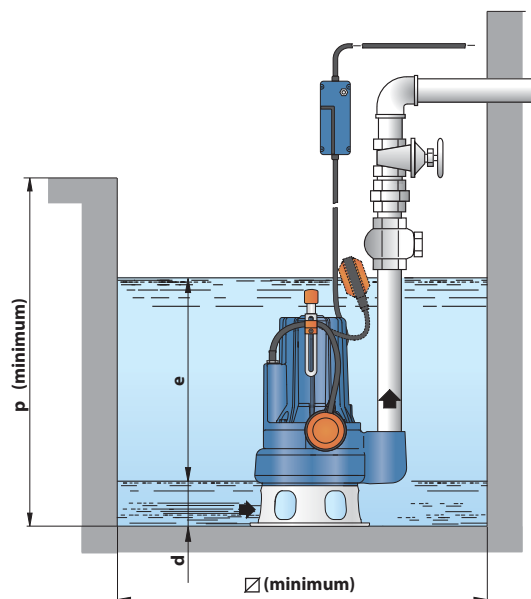

MODEL		PORT DN	solids passage	DIMENSIONS mm									kg	
Single-phase	Three-phase			a	b	c	h	h1	d	e	p	Ø	1~	3~
VXCm 15/50	VXC 15/50	2½"	Ø 50 mm	162	135	214	490	191	75	variable	800	800	36.5	35.1
VXCm 20/50	VXC 20/50						505/490						37.3	36.0
VXCm 30/50	VXC 30/50						505/490						42.0	38.2
VXCm 15/70	VXC 15/70	3"	Ø 70 mm	180	150	241	536	231	85				39.0	38.0
VXCm 20/70	VXC 20/70						550/536						40.8	39.5
VXCm 30/70	VXC 30/70						550/536						45.0	41.0

ABSORPTION

MODEL	VOLTAGE (single-phase)	
	230 V	240 V
VXCm 15/50	8.8 A	8.8 A
VXCm 20/50	10.2 A	10.2 A
VXCm 30/50	15.6 A	15.6 A
VXCm 15/70	8.7 A	8.7 A
VXCm 20/70	10.0 A	10.0 A
VXCm 30/70	15.0 A	15.0 A

MODEL	VOLTAGE (three-phase)					
	230 V	400 V	690 V	240 V	415 V	720 V
VXC 15/50	5.9 A	3.4 A	2.0 A	5.9 A	3.4 A	2.0 A
VXC 20/50	7.3 A	4.2 A	2.4 A	7.3 A	4.2 A	2.4 A
VXC 30/50	9.9 A	5.7 A	3.3 A	9.9 A	5.7 A	3.3 A
VXC 15/70	5.7 A	3.3 A	1.9 A	5.7 A	3.3 A	1.9 A
VXC 20/70	7.3 A	4.2 A	2.4 A	7.3 A	4.2 A	2.4 A
VXC 30/70	9.5 A	5.5 A	3.2 A	9.5 A	5.5 A	3.2 A

PALLETIZATION

MODEL		GROUPAGE / CONTAINER			
Single-phase	Three-phase	n° pumps	H (mm)	kg	
				1~	3~
VXCm 15/50	VXC 15/50	24	1715	892	860
VXCm 20/50	VXC 20/50	24	1715	912	882
VXCm 30/50	VXC 30/50	24	1715	1025	933
VXCm 15/70	VXC 15/70	12	1280	485	472
VXCm 20/70	VXC 20/70	12	1280	507	491
VXCm 30/70	VXC 30/70	12	1280	557	509

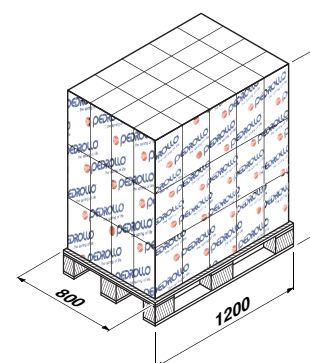

MC "DOUBLE-CHANNEL"

Submersible pumps

for sewage water



PERFORMANCE RANGE

- Flow rate up to **800 l/min** (48 m³/h)
- Head up to **15 m**

APPLICATION LIMITS

- **10 m** maximum immersion depth
- Maximum liquid temperature **+40 °C**
- Passage of suspended solids up to **Ø 50 mm**
- **320 mm** minimum immersion depth for continuous service

CONSTRUCTION AND SAFETY STANDARDS

- Complete with **10 m** long power cable
- Float switch for single-phase versions

EN 60034-1
IEC 60034-1
CEI 2-3



CERTIFICATIONS



АН30



YxpTECT-003

INSTALLATION AND USE

MC series pumps, made from heavy gauge cast iron offering exceptional sturdiness, abrasion resistance and durability, come equipped with a DOUBLE-CHANNEL impeller and are capable of pumping liquids containing short fibred suspended solids up to Ø 50 mm.

They are ideal for pumping **sewage, waste water, water mixed with mud, groundwater and surface water** in locations such as apartment blocks, factories, tower garages, underground car parks and cleaning areas, etc.

PATENTS - TRADE MARKS - MODELS

- Registered Community Design n° 342159-0017

OPTIONALS AVAILABLE ON REQUEST

- Single-phase pumps without float switch
- Other voltages or 60 Hz frequency

GUARANTEE

1 year subject to terms and conditions

CHARACTERISTIC CURVES AND PERFORMANCE DATA

50 Hz n= 2900 1/min

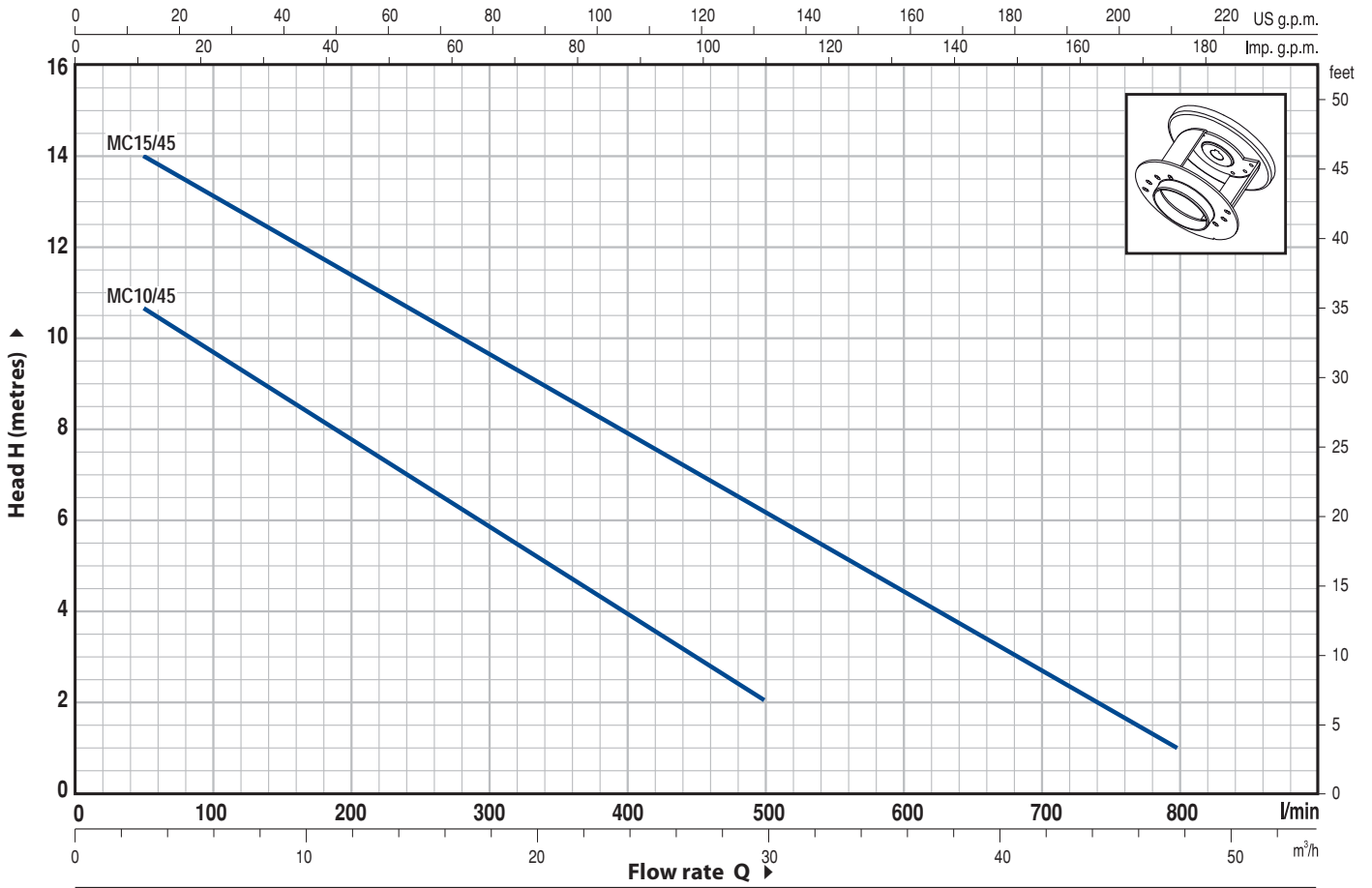

MODEL		POWER		Q	Flow rate															
Single-phase	Three-phase	kW	HP		m³/h	0	3	6	9	12	15	18	21	24	27	30	36	42	48	
MCm 10/45	MC 10/45	0.75	1	l/min	0	50	100	150	200	250	300	350	400	450	500	600	700	800		
MCm 15/45	MC 15/45	1.1	1.5	H metres	12	10.7	9.7	8.7	7.8	6.8	5.9	5	4	3	2					
					15	14	13	12.3	11.5	10.5	9.7	8.8	8	7	6.2	4.5	2.7	1		

Q = Flow rate H = Total manometric head

Tolerance of characteristic curves in compliance with EN ISO 9906 App. A.

POS.	COMPONENT	CONSTRUCTION CHARACTERISTICS
1	PUMP BODY	Cast iron, with threaded port in compliance with ISO 228/1
2	BASE	Stainless steel AISI 304
3	IMPELLER	Stainless steel AISI 304 DOUBLE-CHANNEL type
4	MOTOR CASING	Cast iron
5	MOTOR CASING PLATE	Stainless steel AISI 304
6	MOTOR SHAFT	Stainless steel EN 10088-3 - 1.4104
7	SHAFT WITH DOUBLE SEAL AND OIL CHAMBER	
	<i>Seal</i>	<i>Shaft</i>
	<i>Model</i>	<i>Diameter</i>
	MG1-14 SIC	Ø 14 mm
		<i>Stationary ring</i>
		Ceramic
		<i>Rotational ring</i>
		Silicon carbide
		<i>Elastomer</i>
		NBR
8	LIP SEAL	Ø 15 x Ø 24 x H 5 mm for MC 10/45 Ø 16 x Ø 24 x H 5 mm for MC 15/45
9	BEARINGS	6203 ZZ / 6203 ZZ
10	CAPACITOR	
	<i>Pump</i>	<i>Capacitance</i>
	<i>Single-phase</i>	(230 V or 240 V) (110 V)
	MCm 10/45	20 µF 450 VL 30 µF 250 VL
	MCm 15/45	25 µF 450 VL -
11	ELECTRIC MOTOR	
	<ul style="list-style-type: none"> - Single-phase 230 V - 50 Hz with thermal overload protector built-in to the winding - Three-phase 400 V - 50 Hz - Insulation: F class - Protection: IP 68 	
12	POWER CABLE	
	10 metre long "H07 RN-F" cable (with Schuko plug on single-phase versions only)	

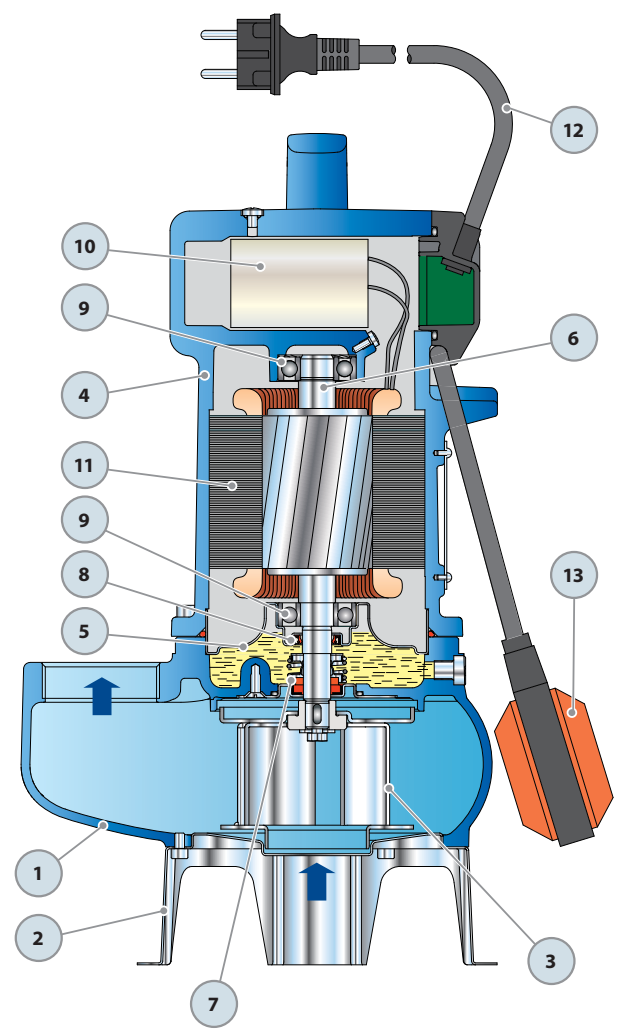

DIMENSIONS AND WEIGHT

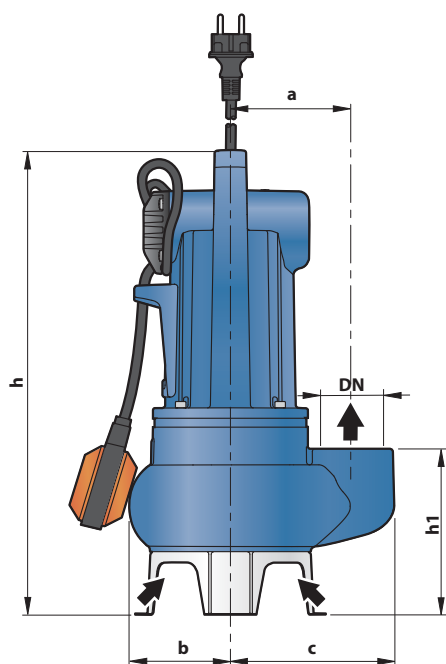

Typical installation

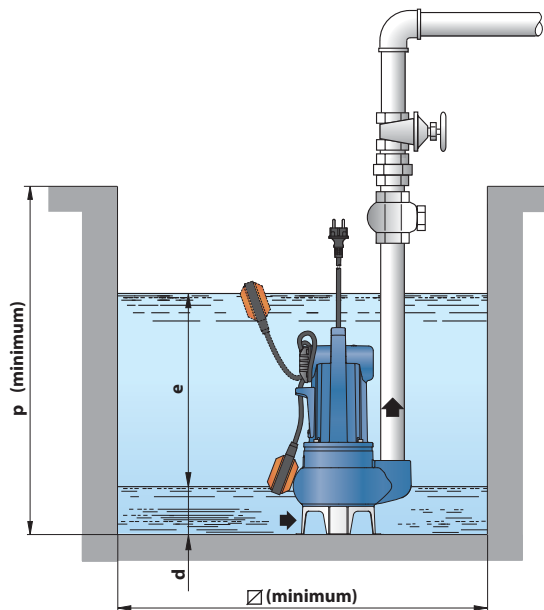

MODEL		PORT DN	solids passage	DIMENSIONS mm									kg	
Single-phase	Three-phase			a	b	c	h	h1	d	e	p	Ø	1~	3~
MCm 10/45	MC 10/45	2"	Ø 50 mm	110	92	150	414	153	60	variable	500	500	20.8	19.2
MCm 15/45	MC 15/45			115	97	157	435	159					23.7	21.8

ABSORPTION

MODEL	VOLTAGE (single-phase)		
	230 V	240 V	110 V
MCm 10/45	5.2 A	5.2 A	11.5 A
MCm 15/45	8.5 A	8.5 A	-

MODEL	VOLTAGE (three-phase)			
	230 V	400 V	240 V	415 V
MC 10/45	3.6 A	2.1 A	3.6 A	2.1 A
MC 15/45	6.1 A	3.5 A	6.1 A	3.5 A

PALLETIZATION

MODEL		GROUPAGE			CONTAINER				
Single-phase	Three-phase	n° pumps	H (mm)	kg		n° pumps	H (mm)	kg	
				1~	3~			1~	3~
MCm 10/45	MC 10/45	45	1400	953	881	60	1820	1265	1169
MCm 15/45	MC 15/45	45	1574	1085	998	60	2052	1441	1325

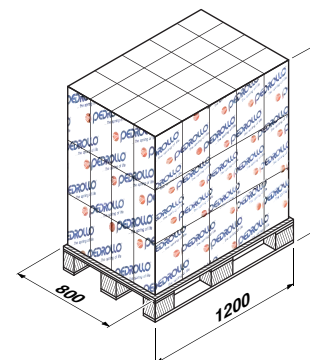

MC "DOUBLE-CHANNEL"

Submersible pumps

for sewage water



PERFORMANCE RANGE

- Flow rate up to **1600 l/min** (96 m³/h)
- Head up to **25 m**

APPLICATION LIMITS

- **10 m** maximum immersion depth
- Maximum liquid temperature **+40 °C**
- Solids passage:
 - up to **Ø 50 mm** for MC 15-20-30-40/50
 - up to **Ø 70 mm** for MC 30-40/70
- Minimum immersion depth for continuous service:
 - **380 mm** for MC 15-20-30-40/50
 - **430 mm** for MC 30-40/70

CONSTRUCTION AND SAFETY STANDARDS

- Complete with **10 m** long power cable
- Float switch for single-phase versions

EN 60034-1
IEC 60034-1
CEI 2-3



CERTIFICATIONS



INSTALLATION AND USE

MC series pumps, made from heavy gauge cast iron offering exceptional sturdiness, abrasion resistance and durability, come equipped with a DOUBLE-CHANNEL impeller and are capable of pumping liquids containing short fibred suspended solids. They are ideal for pumping **sewage, waste water, water mixed with mud, groundwater and surface water** in locations such as apartment blocks, public buildings, factories, tower garages, underground car parks and cleaning areas, etc.

PATENTS - TRADE MARKS - MODELS

- Registered Community Design n° 342159-0017

OPTIONALS AVAILABLE ON REQUEST

- QES control box for three-phase pumps
- Three-phase dual voltage pumps:
 - 230/400 V or
 - 400/690 V
- Single-phase pumps without float switch
- Other voltages or 60 Hz frequency

GUARANTEE

1 year subject to terms and conditions

For the following versions the built-in thermal overload protector must be connected to the control box in order for the guarantee to be considered valid:

- | | |
|--------------------|------------------------------------|
| single-phase | three-phase |
| – MCm 30/50 - HP 3 | – MC 15-20-30-40/50 - HP 1.5-2-3-4 |
| – MCm 30/70 - HP 3 | – MC 30-40/70 - HP 3-4 |

CHARACTERISTIC CURVES AND PERFORMANCE DATA

50 Hz n= 2900 1/min

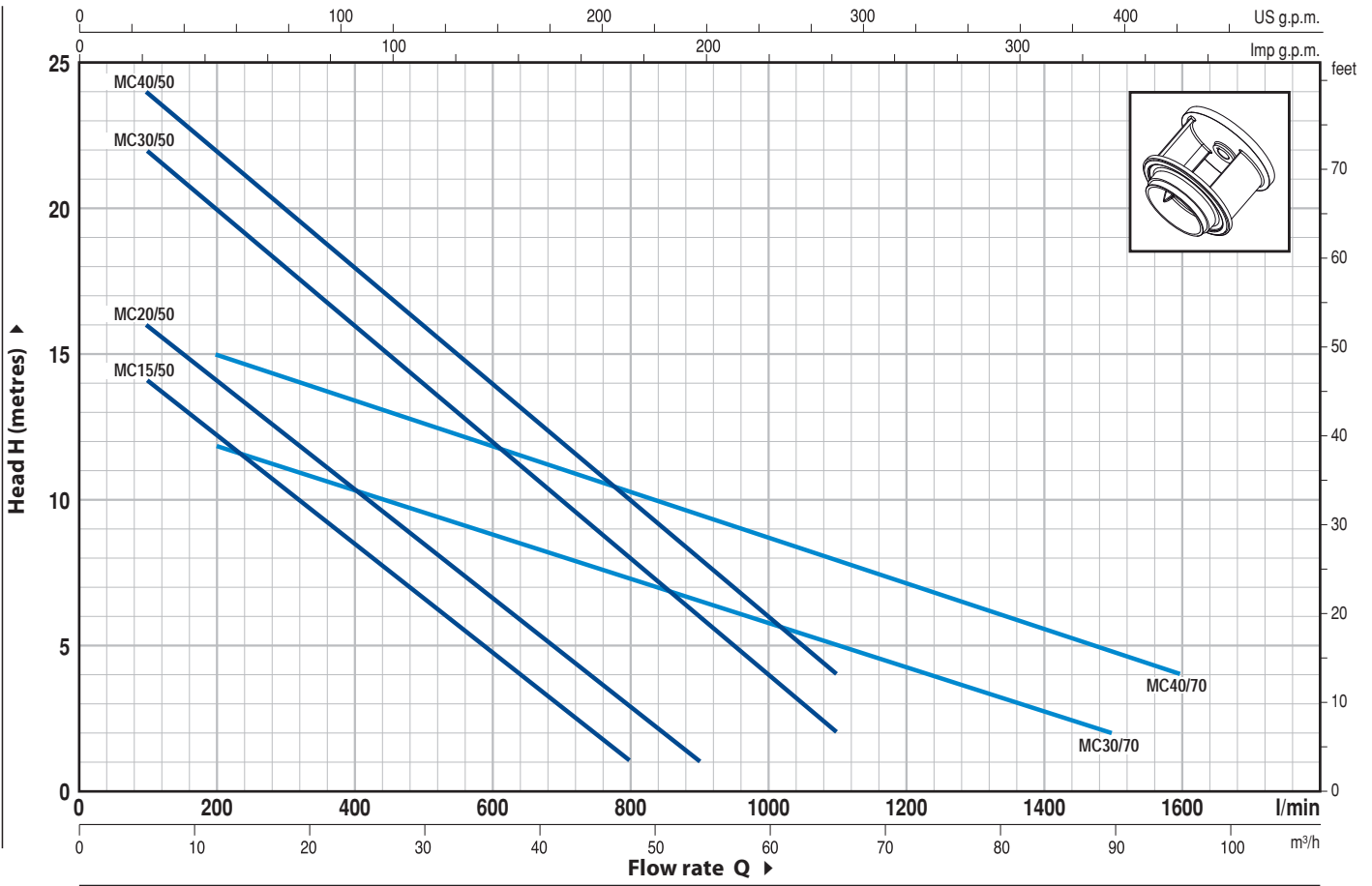

MODEL		POWER		Q	Flow rate																
Single-phase	Three-phase	kW	HP		m ³ /h	0	6	12	18	24	30	36	42	48	54	60	66	72	84	96	
				l/min	0	100	200	300	400	500	600	700	800	900	1000	1100	1200	1400	1600		
MCm 15/50	MC 15/50	1.1	1.5	H metres	16	14	12.5	10.5	8.5	6.5	4.5	3	1								
MCm 20/50	MC 20/50	1.5	2		18	16	14	12.5	10.5	8.5	6.5	5	3	1							
MCm 30/50	MC 30/50	2.2	3		24	22	20	18	16	14	12	10	8	6	4	2					
-	MC 40/50	3	4		25	24	22	20	18	16	14	12	10	8	6	4					
MCm 30/70	MC 30/70	2.2	3		13	-	12	11	10.5	9.5	8.5	8	7.5	6.5	6	5	4.5	3	2		
-	MC 40/70	3	4		17	-	15	14	13.5	12.5	12	11	10.5	9.5	8.5	8	7	5.5	4		

Q = Flow rate H = Total manometric head

Tolerance of characteristic curves in compliance with EN ISO 9906 App. A.

MC "DOUBLE-CHANNEL"

POS.	COMPONENT	CONSTRUCTION CHARACTERISTICS
1	PUMP BODY	Cast iron, with threaded port in compliance with ISO 228/1
2	BASE	Stainless steel AISI 304
3	IMPELLER	Stainless steel AISI 304 DOUBLE-CHANNEL type
4	MOTOR CASING	Cast iron
5	MOTOR CASING PLATE	Cast iron
6	MOTOR SHAFT	Stainless steel AISI 431
7	SHAFT WITH DOUBLE SEAL AND OIL CHAMBER	
	<i>Seal</i>	<i>Shaft</i>
	<i>Model</i>	<i>Diameter</i>
	FN-20 DV	Ø 20 mm
		<i>Stationary ring</i>
		Widia
		<i>Rotational ring</i>
		Silicon carbide
		<i>Elastomer</i>
		NBR
8	LIP SEAL	Ø 20 x Ø 30 x H 7 mm
9	BEARINGS	6304 ZZ - C3 / 6304 ZZ - C3
10	CAPACITOR	
	<i>Pump</i>	<i>Capacitance</i>
	<i>Single-phase</i>	<i>(230 V or 240 V)</i>
	MCm 15/50	31.5 µF 450 VL
	MCm 20/50	50 µF 450 VL
	MCm 30/50	60 µF 450 VL
	MCm 30/70	60 µF 450 VL
11	ELECTRIC MOTOR	
	MCm 15-20: single-phase 230 V - 50 Hz with thermal overload protector built-in to the winding	
	⇒ MCm 30: single-phase 230 V - 50 Hz with thermal overload protector built-in to the winding to be connected to the control box	
	⇒ MC: three-phase 400 V - 50 Hz. with thermal overload protector built-in to the winding to be connected to the control box	
	– Insulation: F class	
	– Protection: IP 68	
12	POWER CABLE	
	10 metre long "H07 RN-F" cable	
13	CONTROL BOX for MCm 15-20	
	(only for single-phase versions)	
	Complete with capacitor and manual reset motor protector	
14	CONTROL BOX for MCm 30	
	(only for single-phase versions)	
	QES 300 MONO series	
15	FLOAT SWITCH	
	(only for single-phase versions)	

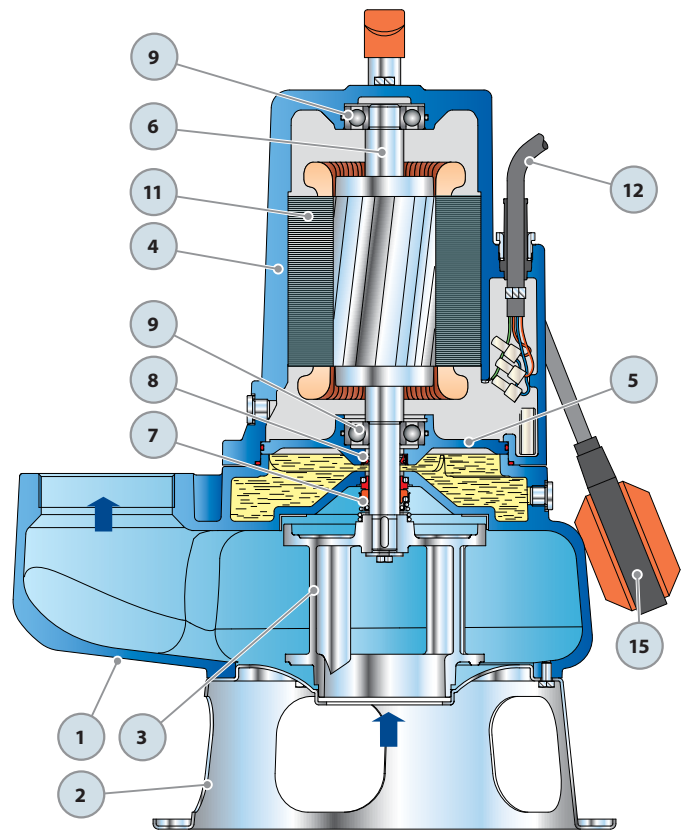

Standard features

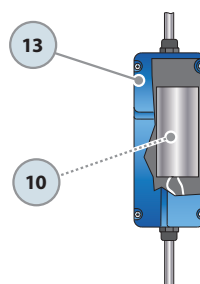

Control box for MCm 15-20
(only for single-phase versions)

Standard features

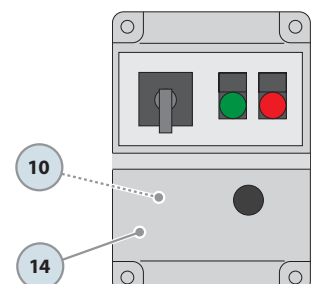

Control box for MCm 30
(only for single-phase versions)

DIMENSIONS AND WEIGHT

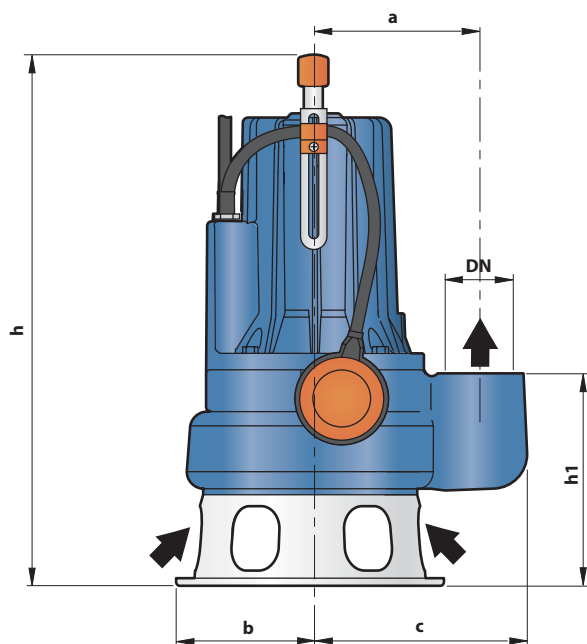

Typical installation

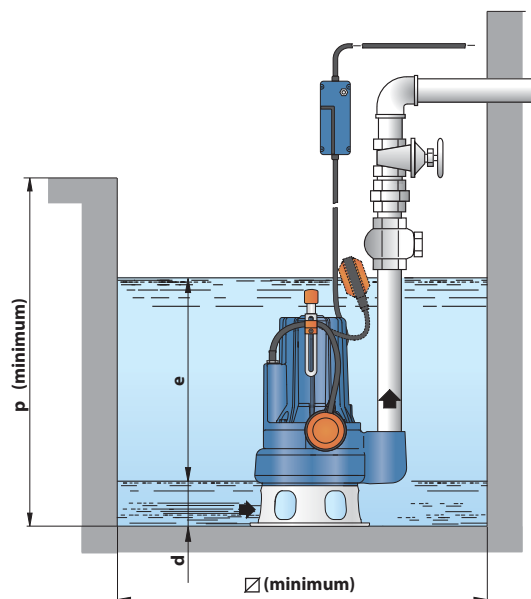

MODEL		PORT DN	solids passage	DIMENSIONS mm									kg	
Single-phase	Three-phase			a	b	c	h	h1	d	e	p	∅	1~	3~
MCm 15/50	MC 15/50	2½"	∅ 50 mm	162	135	214	490	191	75	variable	800	800	37.1	35.9
MCm 20/50	MC 20/50						505/490						39.0	36.8
MCm 30/50	MC 30/50						505						43.2	39.2
-	MC 40/50						536						-	42.2
MCm 30/70	MC 30/70	3"	∅ 70 mm	180	150	241	536	231	85	variable	800	800	48.3	42.6
-	MC 40/70						550/536						-	48.1

ABSORPTION

MODEL	VOLTAGE (single-phase)	
	230 V	240 V
Single-phase	230 V	240 V
MCm 15/50	9.0 A	9.0 A
MCm 20/50	10.5 A	10.5 A
MCm 30/50	15.2 A	15.2 A
MCm 30/70	15.2 A	15.2 A

MODEL	VOLTAGE (three-phase)					
	230 V	400 V	690 V	240 V	415 V	720 V
Three-phase	230 V	400 V	690 V	240 V	415 V	720 V
MC 15/50	5.5 A	3.2 A	1.8 A	5.5 A	3.2 A	1.8 A
MC 20/50	7.4 A	4.3 A	2.5 A	7.4 A	4.3 A	2.5 A
MC 30/50	9.9 A	5.7 A	3.3 A	9.9 A	5.7 A	3.3 A
MC 40/50	13.5 A	7.8 A	4.5 A	13.5 A	7.8 A	4.5 A
MC 30/70	10.2 A	5.9 A	3.4 A	10.2 A	5.9 A	3.4 A
MC 40/70	13.5 A	7.8 A	4.5 A	13.5 A	7.8 A	4.5 A

PALLETIZATION

MODEL		GROUPAGE / CONTAINER			
Single-phase	Three-phase	n° pumps	H (mm)	kg	
				1~	3~
MCm 15/50	MC 15/50	24	1715	908	879
MCm 20/50	MC 20/50	24	1715	953	901
MCm 30/50	MC 30/50	24	1715	1054	958
-	MC 40/50	24	1715	-	1030
MCm 30/70	MC 30/70	12	1280	596	528
-	MC 40/70	12	1280	-	594

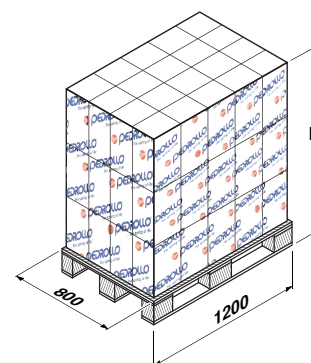

PVXC "VORTEX"

Fixed installation pumps

for sewage water



PERFORMANCE RANGE

- Flow rate up to **1200 l/min** (72 m³/h)
- Head up to **16 m**

APPLICATION LIMITS

- **10 m** maximum immersion depth
- Maximum liquid temperature **+40 °C**
- Solids passage:
 - up to **Ø 50 mm** for PVXC 15-20-30/50
 - up to **Ø 70 mm** for PVXC 15-20-30/70
- Minimum immersion depth for continuous service:
 - **390 mm** for PVXC 15-20-30/50
 - **440 mm** for PVXC 15-20-30/70

CONSTRUCTION AND SAFETY STANDARDS

- Standard features: base pedestal, threaded delivery counterflange, guide tube supports
- **10 m** long power cable
- Float switch for single-phase versions

EN 60034-1
IEC 60034-1
CEI 2-3



CERTIFICATIONS



AN30



UKPTECT-003

INSTALLATION AND USE

PVXC series pumps, made from heavy gauge cast iron offering exceptional sturdiness, abrasion resistance and durability, come equipped with a VORTEX impeller and are therefore suitable for draining **waste water, water mixed with mud, liquids containing air or gas**, as well as sludge. They are suitable for use in fixed sewer, tunnel, well and underground car park installations.

PATENTS - TRADE MARKS - MODELS

- Registered Community Design n° 342159-0017

OPTIONALS AVAILABLE ON REQUEST

- QES control box for three-phase pumps
- Three-phase dual voltage pumps:
 - 230/400 V or
 - 400/690 V
- Single-phase pumps without float switch
- Other voltages or 60 Hz frequency

GUARANTEE

1 year subject to terms and conditions

For the following versions the built-in thermal overload protector must be connected to the control box in order for the guarantee to be considered valid:

single-phase

– PVXCm 30/50 - HP 3

– PVXCm 30/70 - HP 3

three-phase

– PVXC 15-20-30/50 - HP 1.5-2-3

– PVXC 15-20-30/70 - HP 1.5-2-3

CHARACTERISTIC CURVES AND PERFORMANCE DATA

50 Hz n= 2900 1/min

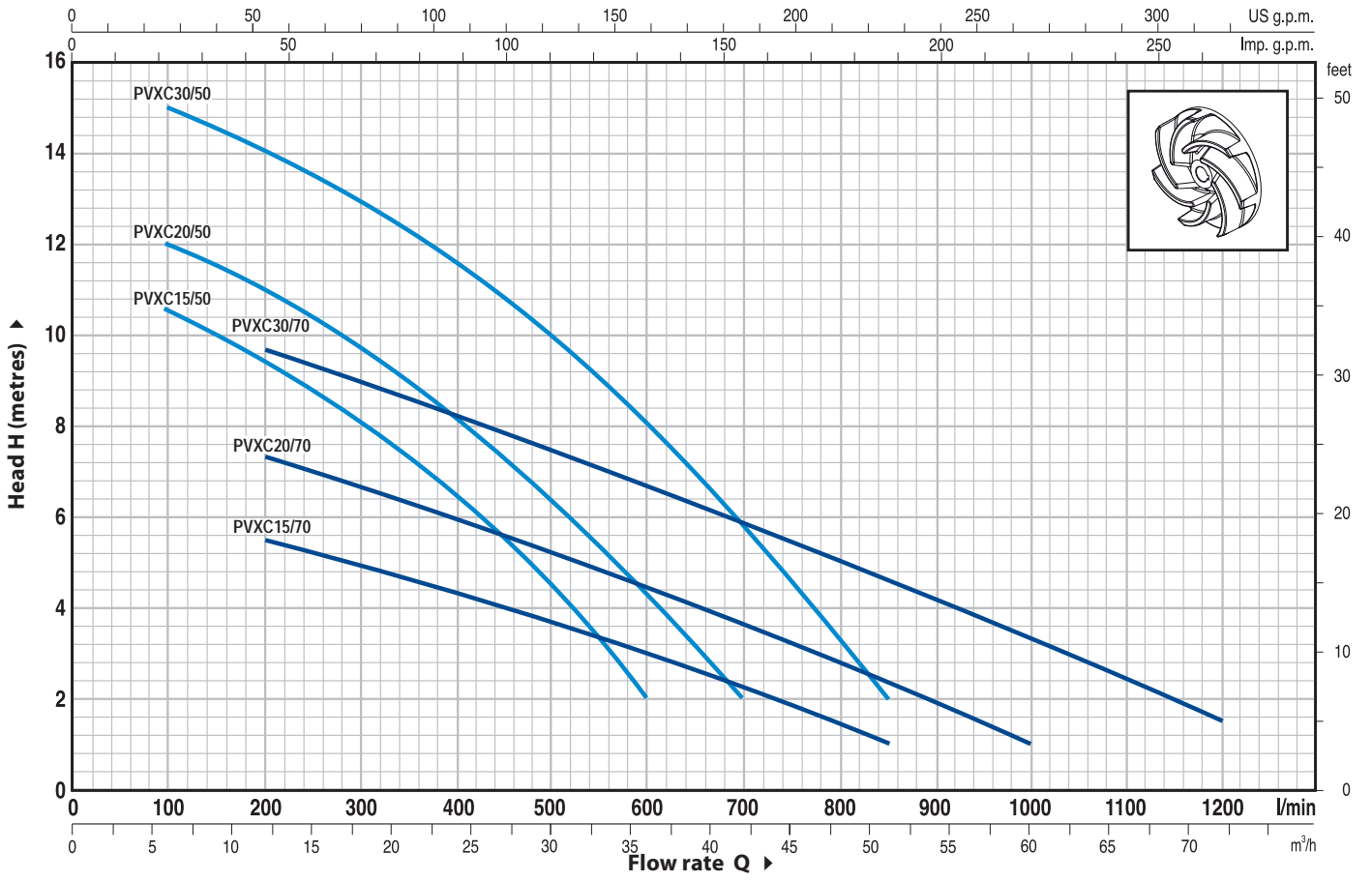

MODEL		POWER		Q	Flow rate																		
Single-phase	Three-phase	kW	HP		m³/h	0	6	12	18	21	24	27	30	36	42	48	51	54	60	66	72		
				l/min	0	100	200	300	350	400	450	500	600	700	800	850	900	1000	1100	1200			
PVXCm 15/50	PVXC 15/50	1.1	1.5	H metres	11.5	10.5	9.5	8.2	7.2	6.5	5.6	4.5	2										
PVXCm 20/50	PVXC 20/50	1.5	2		13	12	11	9.5	9	8	7.2	6.5	4.5	2									
PVXCm 30/50	PVXC 30/50	2.2	3		16	15	14	13	12.3	11.5	10.8	10	8	5.9	3.3	2							
PVXCm 15/70	PVXC 15/70	1.1	1.5		6.5	-	5.5	5	4.7	4.4	4	3.7	3	2.2	1.5	1							
PVXCm 20/70	PVXC 20/70	1.5	2		8.5	-	7.4	6.7	6.3	6	5.6	5.2	4.5	3.6	2.8	2.4	2	1					
PVXCm 30/70	PVXC 30/70	2.2	3		11	-	9.7	9	8.6	8.2	7.8	7.5	6.7	5.8	5	4.6	4.2	3.3	2.5	1.5			

Q = Flow rate H = Total manometric head

Tolerance of characteristic curves in compliance with EN ISO 9906 App. A.

PVXC "VORTEX"

POS. CONSTRUCTION CHARACTERISTICS

1	PUMP BODY	Cast iron, complete with flanged ports	
2	SUCTION PLATE	Cast iron	
3	BASE PEDESTAL	Cast iron	
4	CONTERFLANGE	Steel, complete with threaded ports in compliance with ISO 228/1	
5	GUIDE TUBE SUPPORTS	Cast iron	
6	IMPELLER	Cast iron VORTEX type	
7	MOTOR CASING	Cast iron	
8	MOTOR CASING PLATE	Cast iron	
9	MOTOR SHAFT	Stainless steel AISI 431	
10	SHAFT WITH DOUBLE SEAL AND OIL CHAMBER		
	Seal	Shaft	Materials
	<i>Model</i>	<i>Diameter</i>	<i>Stationary ring</i> <i>Rotational ring</i> <i>Elastomer</i>
	FN-20 DV	Ø 20 mm	Widia Silicon carbide NBR
11	LIP SEAL	Ø 20 x Ø 30 x H 7 mm	
12	BEARINGS	6304 ZZ - C3 / 6304 ZZ - C3	

POS. CONSTRUCTION CHARACTERISTICS

13 CAPACITOR

<i>Pump</i>	<i>Capacitance</i>
<i>Single-phase</i>	<i>(230 V or 240 V)</i>
PVXCm 15/50-70	31.5 µF 450 VL
PVXCm 20/50-70	50 µF 450 VL
PVXCm 30/50-70	60 µF 450 VL

14 ELECTRIC MOTOR

PVXCm 15-20: single-phase 230 V - 50 Hz with thermal overload protector built-in to the winding.

⇒ **PVXCm 30:** single-phase 230 V - 50 Hz with motor protector built-in to the winding to be connected to the control box

⇒ **PVXC:** three-phase 400 V - 50 Hz with motor protector built-in to the winding to be connected to the control box

– Insulation: F class

– Protection: IP 68

15 POWER CABLE

10 m long "H07 RN-F" cable

16 CONTROL BOX for PVXCm 15-20

(only for single-phase versions)

Complete with capacitor and manual reset motor protector

17 CONTROL BOX for PVXCm 30

(only for single-phase versions)

QES 300 MONO series

18 FLOAT SWITCH

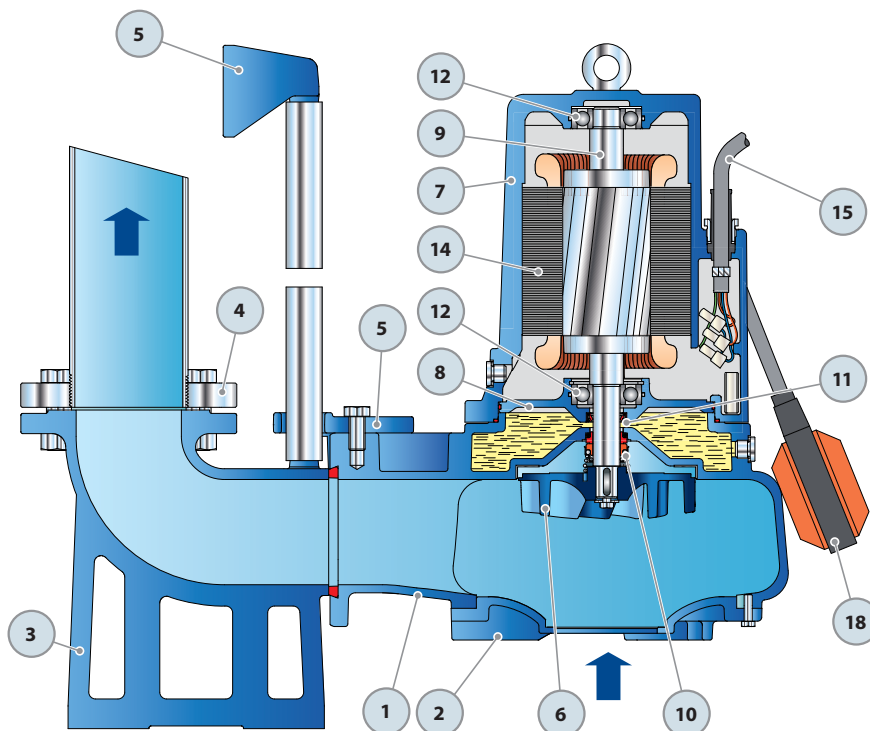

Standard features

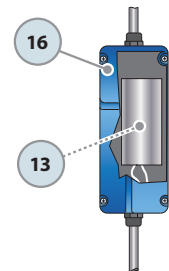

Control box for PVXCm 15-20 (HP 1.5-2.0)
(only for single-phase versions)

Standard features

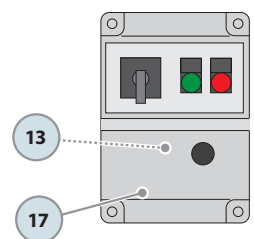

Control box for PVXCm 30 (HP 3.0)
(only for single-phase versions)

DIMENSIONS AND WEIGHT

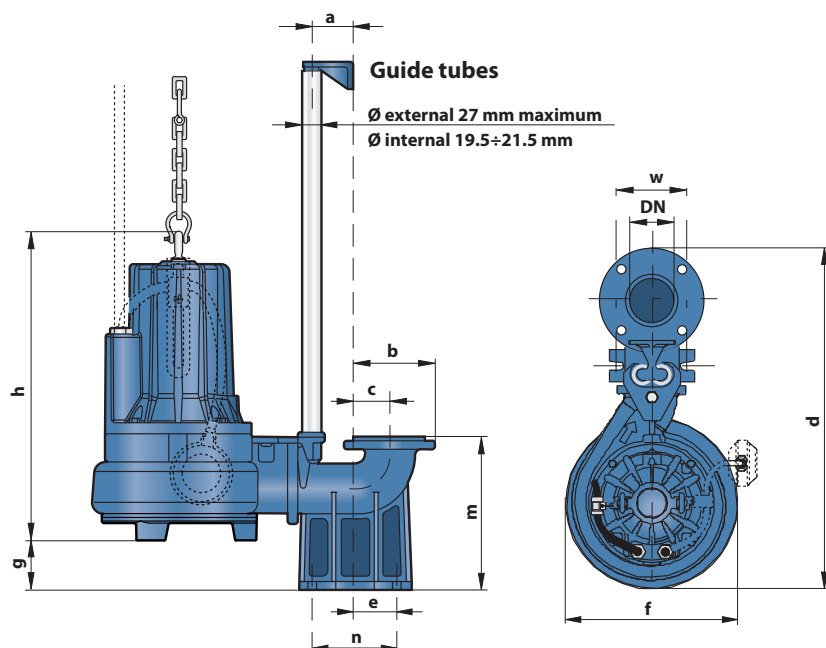

Typical installation

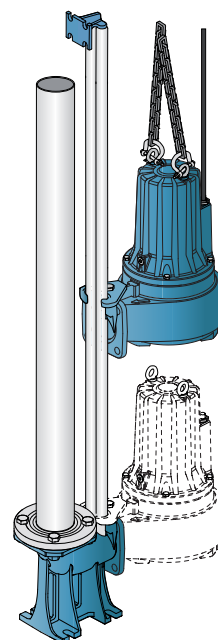

MODEL		PORT DN	solids passage	DIMENSIONS mm										kg*		
Single-phase	Three-phase			a	b	c	d	e	f	g	h	m	n	w	1~	3~
PVXCm 15/50	PVXC 15/50	2½"	Ø 50 mm	60	116	51	490	62	250	52	330	198	120	72	46.9	44.7
PVXCm 20/50	PVXC 20/50										445 / 430				48.0	46.9
PVXCm 30/50	PVXC 30/50										49.7				48.9	
PVXCm 15/70	PVXC 15/70	3"	Ø 70 mm		150	70	570	85	270	87	446	255	130	112	53.6	50.7
PVXCm 20/70	PVXC 20/70										460 / 446				56.0	55.5
PVXCm 30/70	PVXC 30/70										60.0				57.6	

(*weight includes counterflanges)

ABSORPTION

MODEL	VOLTAGE (single-phase)	
	230 V	240 V
Single-phase	230 V	240 V
PVXCm 15/50	8.8 A	8.8 A
PVXCm 20/50	10.2 A	10.2 A
PVXCm 30/50	15.6 A	15.6 A
PVXCm 15/70	8.7 A	8.7 A
PVXCm 20/70	10.0 A	10.0 A
PVXCm 30/70	15.0 A	15.0 A

MODEL	VOLTAGE (single-phase)					
	230 V	400 V	690 V	240 V	415 V	720 V
Three-phase	230 V	400 V	690 V	240 V	415 V	720 V
PVXC 15/50	5.9 A	3.4 A	2.0 A	5.9 A	3.4 A	2.0 A
PVXC 20/50	7.3 A	4.2 A	2.4 A	7.3 A	4.2 A	2.4 A
PVXC 30/50	9.9 A	5.7 A	3.3 A	9.9 A	5.7 A	3.3 A
PVXC 15/70	5.7 A	3.3 A	1.9 A	5.7 A	3.3 A	1.9 A
PVXC 20/70	7.3 A	4.2 A	2.4 A	7.3 A	4.2 A	2.4 A
PVXC 30/70	9.5 A	5.5 A	3.2 A	9.5 A	5.5 A	3.2 A

PALLETIZATION

MODEL		GROUPAGE / CONTAINER			
Single-phase	Three-phase	n° pumps	H (mm)	kg	
				1~	3~
PVXCm 15/50	PVXC 15/50	24	1715	1143	1090
PVXCm 20/50	PVXC 20/50	24	1715	1169	1142
PVXCm 30/50	PVXC 30/50	24	1715	1210	1191
PVXCm 15/70	PVXC 15/70	12	1280	660	625
PVXCm 20/70	PVXC 20/70	12	1280	689	683
PVXCm 30/70	PVXC 30/70	12	1280	737	708

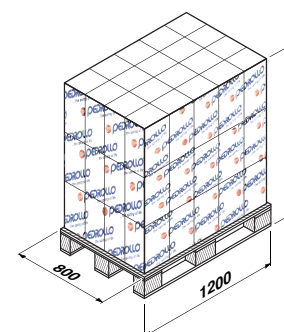

PMC "DOUBLE-CHANNEL"

Fixed installation pumps

for sewage water



PERFORMANCE RANGE

- Flow rate up to **1600 l/min** (96 m³/h)
- Head up to **25 m**

APPLICATION LIMITS

- **10 m** maximum immersion depth
- Maximum liquid temperature **+40 °C**
- Solids passage:
 - up to **Ø 50 mm** for PMC 15-20-30-40/50
 - up to **Ø 70 mm** for PMC 30-40/70
- Minimum immersion depth for continuous service:
 - **390 mm** for PMC 15-20-30-40/50
 - **440 mm** for PMC 30-40/70

CONSTRUCTION AND SAFETY STANDARDS

- Standard features: base pedestal, threaded delivery counterflange, guide tube supports
- **10 m** long power cable
- PMCm versions complete with float switch

EN 60034-1
IEC 60034-1
CEI 2-3



CERTIFICATIONS



AN30



UKPTECT-003

INSTALLATION AND USE

PMC pumps, made from heavy gauge cast iron offering exceptional sturdiness and abrasion resistance, come equipped with a DOUBLE-CHANNEL stainless steel impeller and are capable of pumping liquids containing short fibred suspended solids. They are ideal for pumping **sewage, waste water, water mixed with mud, groundwater and surface water** in locations such as apartment blocks, public buildings, factories, tower garages, underground car parks and cleaning areas, etc.

PATENTS - TRADE MARKS - MODELS

- Registered Community Design n° 342159-0017

OPTIONALS AVAILABLE ON REQUEST

- QES control box for three-phase pumps
- Three-phase dual voltage pumps:
 - 230/400 V or
 - 400/690 V
- Single-phase pumps without float switch
- Other voltages or 60 Hz frequency

GUARANTEE

1 year subject to terms and conditions

For the following versions the built-in thermal overload protector must be connected to the control box in order for the guarantee to be considered valid:

single-phase	three-phase
– PMCm 30/50 - HP 3	– PMC 15-20-30-40/50 - HP 1.5-2-3-4
– PMCm 30/70 - HP 3	– PMC 30-40/70 - HP 3-4

CHARACTERISTIC CURVES AND PERFORMANCE DATA

50 Hz n= 2900 1/min

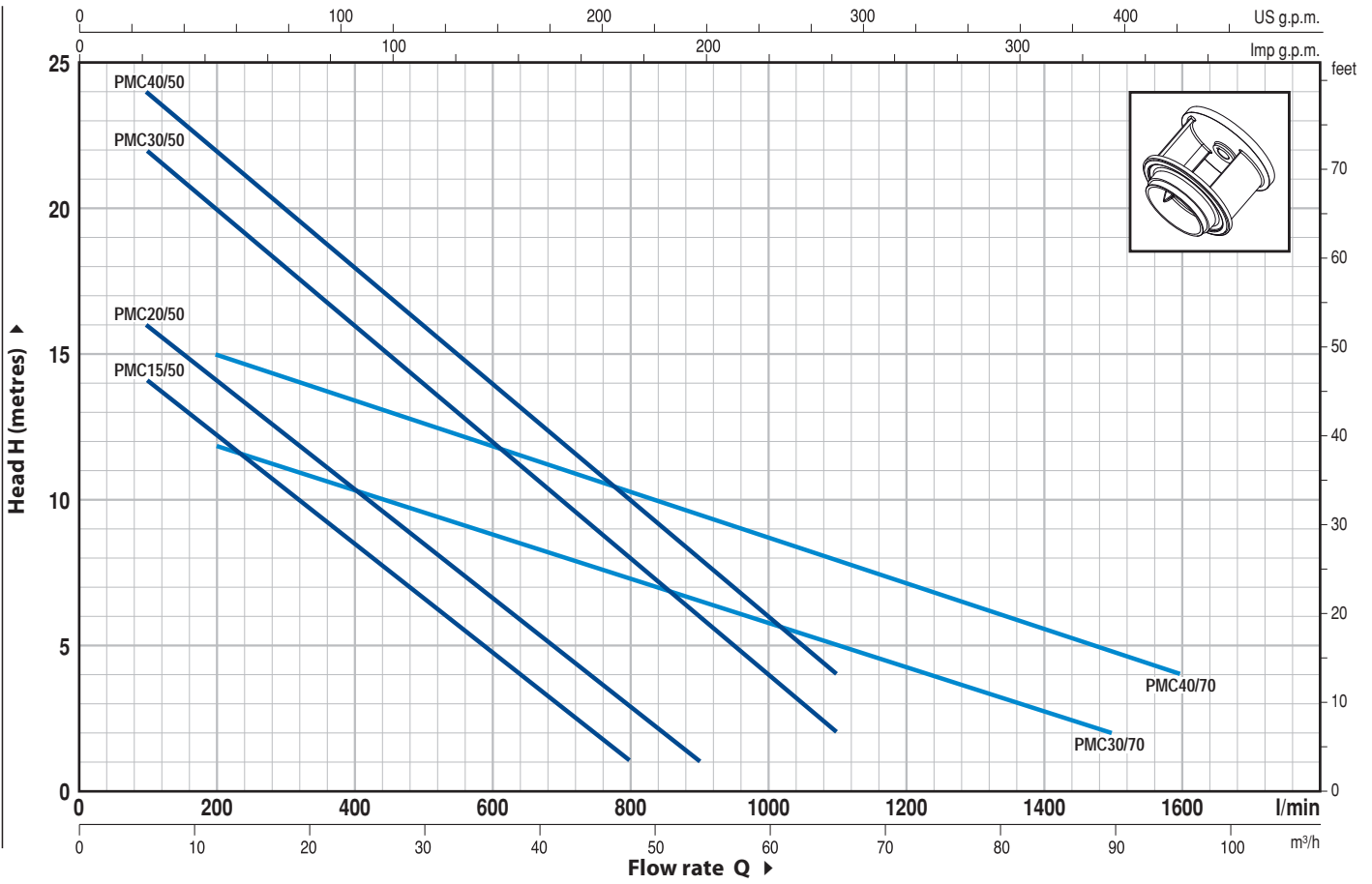

MODEL		POWER		Q	H metres																
Single-phase	Three-phase	kW	HP		m³/h	0	6	12	18	24	30	36	42	48	54	60	66	72	84	96	
				l/min	0	100	200	300	400	500	600	700	800	900	1000	1100	1200	1400	1600		
PMCm 15/50	PMC 15/50	1.1	1.5	H metres	16	14	12.5	10.5	8.5	6.5	4.5	3	1								
PMCm 20/50	PMC 20/50	1.5	2		18	16	14	12.5	10.5	8.5	6.5	5	3	1							
PMCm 30/50	PMC 30/50	2.2	3		24	22	20	18	16	14	12	10	8	6	4	2					
-	PMC 40/50	3	4		25	24	22	20	18	16	14	12	10	8	6	4					
PMCm 30/70	PMC 30/70	2.2	3		13	-	12	11	10.5	9.5	8.5	8	7.5	6.5	6	5	4.5	3	2		
-	PMC 40/70	3	4		17	-	15	14	13.5	12.5	12	11	10.5	9.5	8.5	8	7	5.5	4		

Q = Flow rate H = Total manometric head

Tolerance of characteristic curves in compliance with EN ISO 9906 App. A.

PMC "DOUBLE-CHANNEL"

POS. CONSTRUCTION CHARACTERISTICS

1	PUMP BODY	Cast iron, complete with flanged ports	
2	SUCTION PLATE	Cast iron	
3	BASE PEDESTAL	Cast iron	
4	CONTERFLANGE	Steel, complete with threaded ports in compliance with ISO 228/1	
5	GUIDE TUBE SUPPORTS	Cast iron	
6	IMPELLER	Stainless steel AISI 304 DOUBLE-CHANNEL type	
7	MOTOR CASING	Cast iron	
8	MOTOR CASING PLATE	Cast iron	
9	MOTOR SHAFT	Stainless steel AISI 431	
10	SHAFT WITH DOUBLE SEAL AND OIL CHAMBER		
	Seal	Shaft	Materials
	<i>Model</i>	<i>Diameter</i>	<i>Stationary ring</i> <i>Rotational ring</i> <i>Elastomer</i>
	FN-20 DV	Ø 20 mm	Widia Silicon carbide NBR
11	LIP SEAL	Ø 20 x Ø 30 x H 7 mm	
12	BEARINGS	6304 ZZ - C3 / 6304 ZZ - C3	

POS. CONSTRUCTION CHARACTERISTICS

13 CAPACITOR

<i>Pump</i>	<i>Capacitance</i>
<i>Single-phase</i>	<i>(230 V or 240 V)</i>
PM Cm 15/50	31.5 µF 450 VL
PM Cm 20/50	50 µF 450 VL
PM Cm 30/50-70	60 µF 450 VL

14 ELECTRIC MOTOR

PM Cm 15-20: single-phase 230 V - 50 Hz with thermal overload protector built-in to the winding.

⇒ **PM Cm 30:** single-phase 230 V - 50 Hz with motor protector built-in to the winding to be connected to the control box

⇒ **PMC:** three-phase 400 V - 50 Hz with motor protector built-in to the winding to be connected to the control box

– Insulation: F class

– Protection: IP 68

15 POWER CABLE

10 m long "H07 RN-F" cable

16 CONTROL BOX foe PM Cm 15-20

(only for single-phase versions)

Complete with capacitor and manual reset motor protector

17 CONTROL BOX for PM Cm 30

(only for single-phase versions)

QES 300 MONO series

18 FLOAT SWITCH

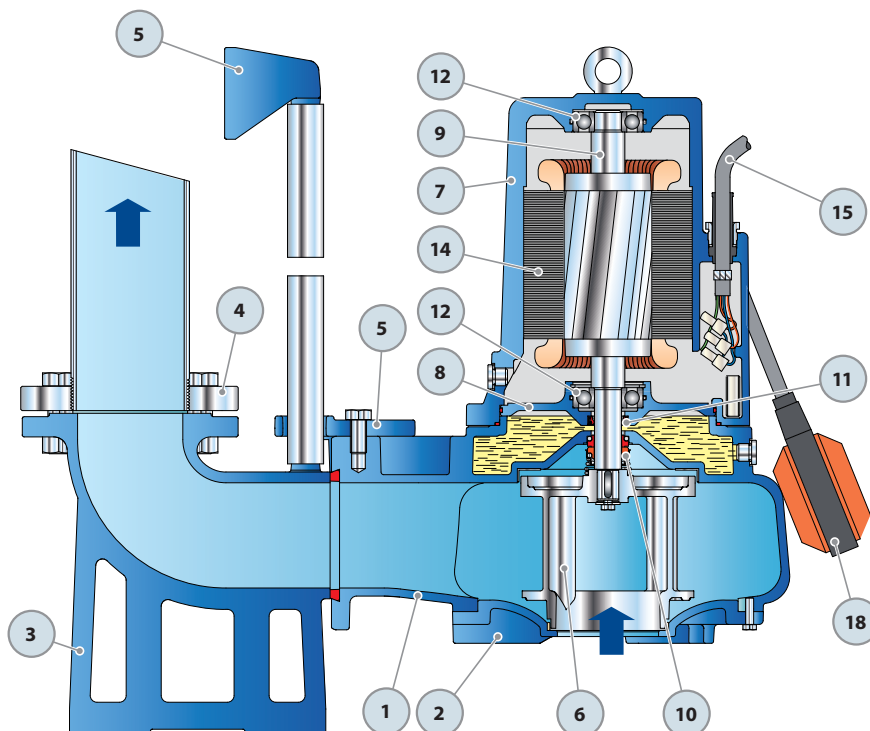

Standard features

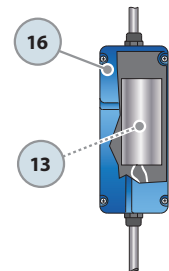

Control box for
PM Cm 15-20 (HP 1.5-2.0)
(only for single-phase versions)

Standard features

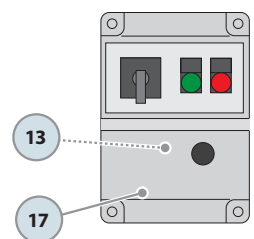

Control box for
PM Cm 30 (HP 3.0)
(only for single-phase versions)

DIMENSIONS AND WEIGHT

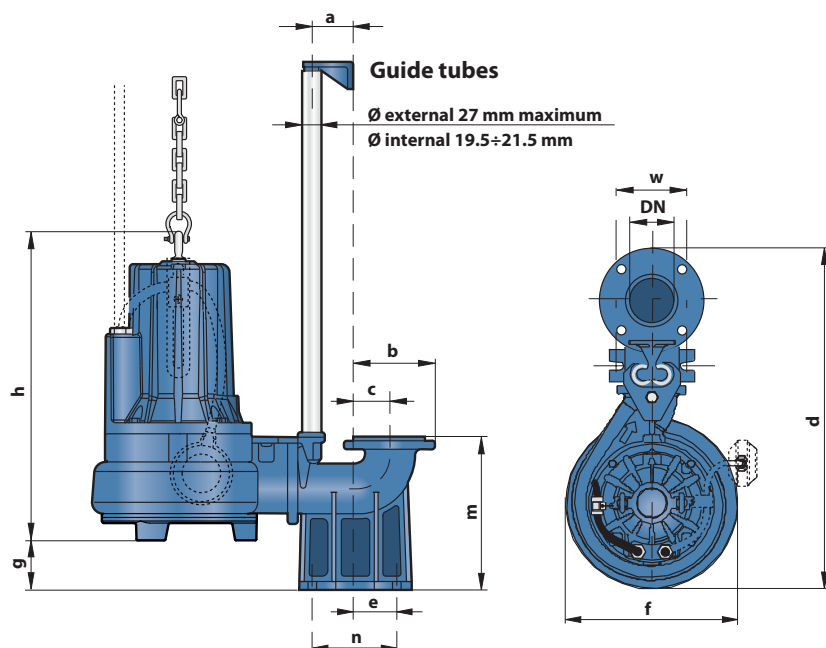

Typical installation

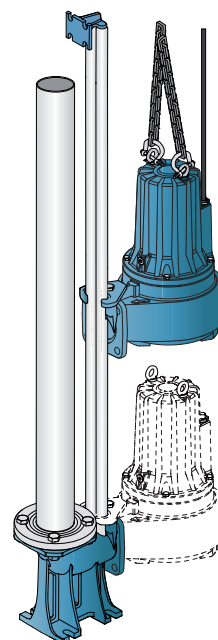

MODEL		PORT DN	solids passage	DIMENSIONS mm										kg*		
Single-phase	Three-phase			a	b	c	d	e	f	g	h	m	n	w	1~	3~
PMcM 15/50	PMC 15/50	2½"	Ø 50 mm	60	116	51	490	62	250	52	330	198	120	72	46.7	45.4
PMcM 20/50	PMC 20/50										445/430				48.0	46.0
PMcM 30/50	PMC 30/50										445				52.2	48.7
-	PMC 40/50	3"	Ø 70 mm		150	70	570	85	270	87	460/446	255	130	112	61.0	57.4
PMcM 30/70	PMC 30/70										460				-	60.8
-	PMC 40/70										-				-	60.8

(*weight includes counterflanges)

ABSORPTION

MODEL	VOLTAGE (single-phase)	
Single-phase	230 V	240 V
PMcM 15/50	9.0 A	9.0 A
PMcM 20/50	10.5 A	10.5 A
PMcM 30/50	15.2 A	15.2 A
PMcM 30/70	15.2 A	15.2 A

MODEL	VOLTAGE (three-phase)					
Three-phase	230 V	400 V	690 V	240 V	415 V	720 V
PMC 15/50	6.1 A	3.5 A	2 A	6.1 A	3.5 A	2.0 A
PMC 20/50	7.4 A	4.3 A	2.5 A	7.4 A	4.3 A	2.5 A
PMC 30/50	9.9 A	5.7 A	3.3 A	9.9 A	5.7 A	3.3 A
PMC 40/50	13.5 A	7.8 A	4.5 A	13.5 A	7.8 A	4.5 A
PMC 30/70	10.2 A	5.9 A	3.4 A	10.2 A	5.9 A	3.4 A
PMC 40/70	13.5 A	7.8 A	4.5 A	13.5 A	7.8 A	4.5 A

PALLETIZATION

MODEL		GROUPAGE / CONTAINER			
Single-phase	Three-phase	n° pumps	H (mm)	kg	
PMcM 15/50	PMC 15/50	24	1715	1139	1107
PMcM 20/50	PMC 20/50	24	1715	1169	1121
PMcM 30/50	PMC 30/50	24	1715	1270	1185
-	PMC 40/50	24	1715	-	1265
PMcM 30/70	PMC 30/70	12	1280	749	706
-	PMC 30/70	12	1280	-	747

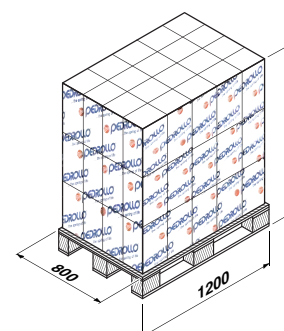

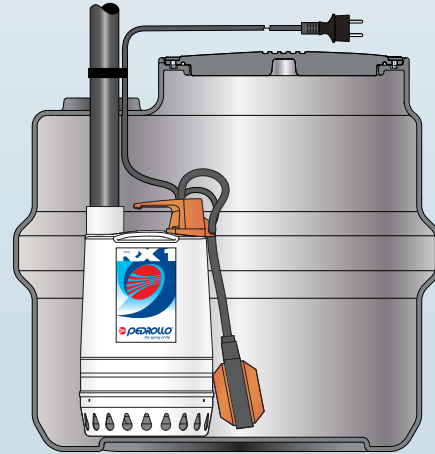
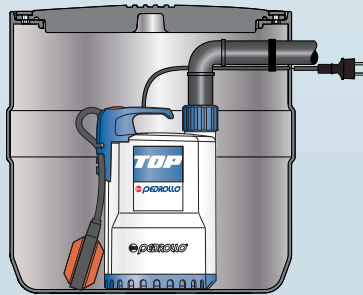

PERFORMANCE RANGE

50 Hz n= 2900 1/min

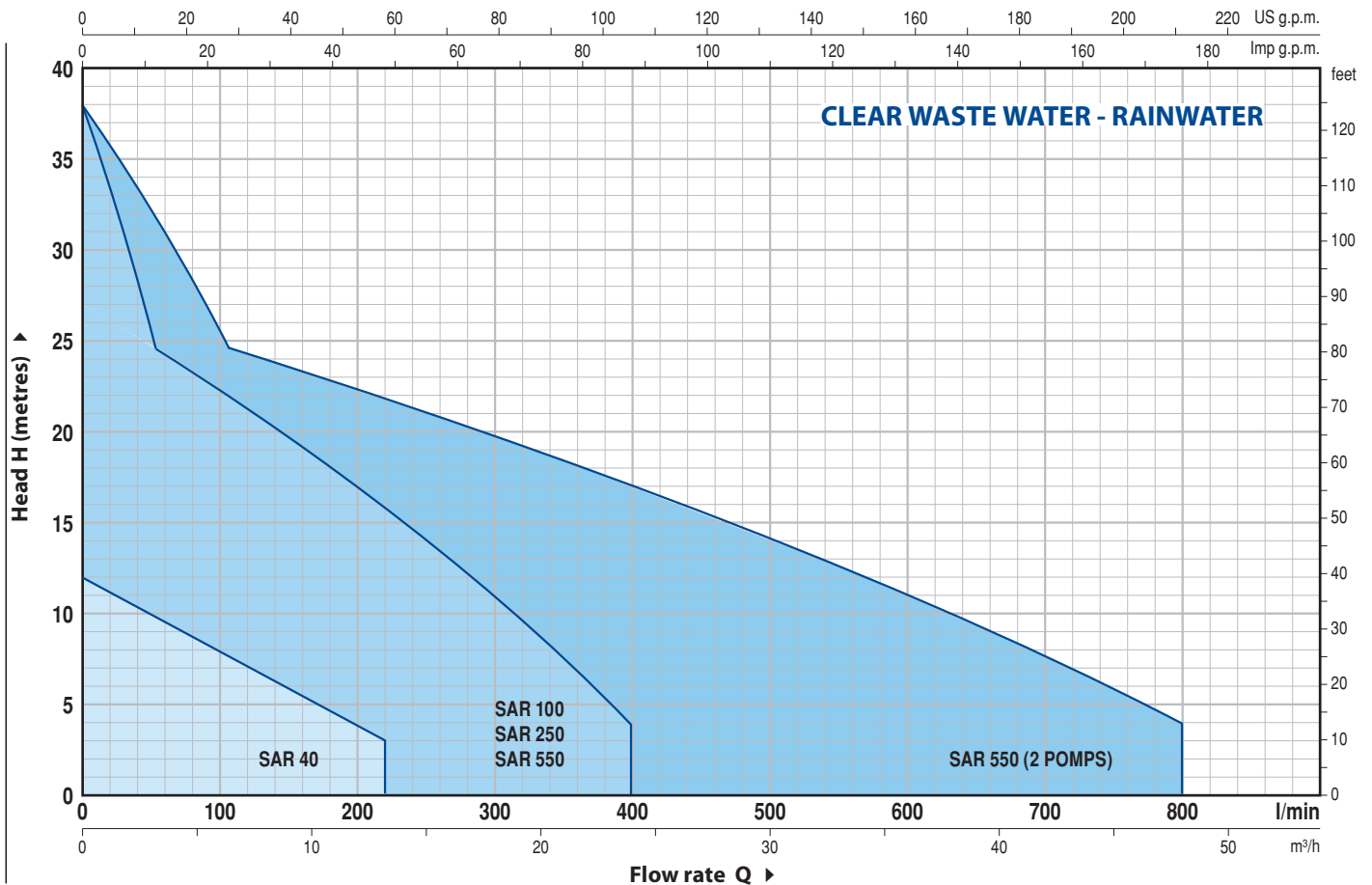

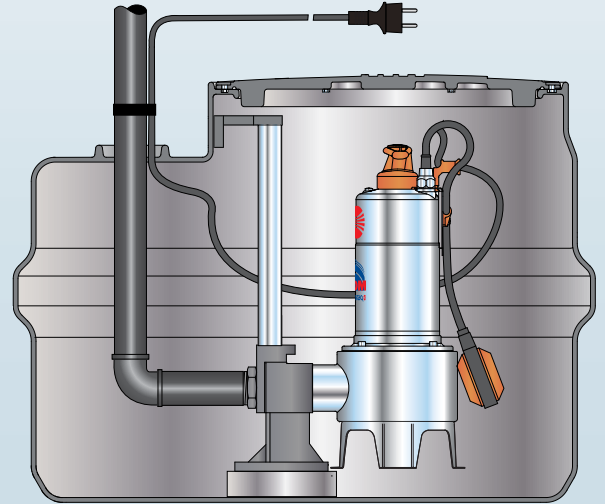
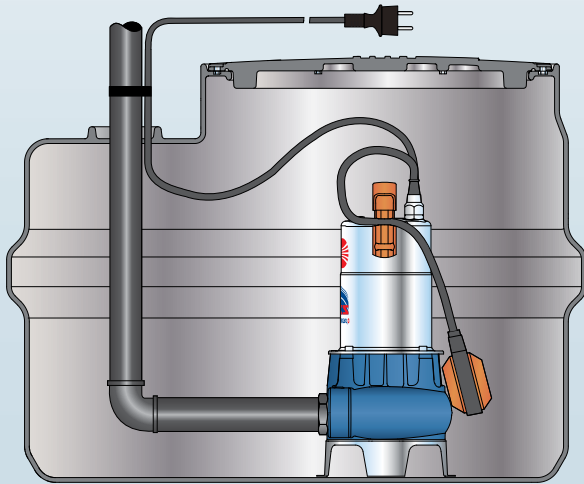

PERFORMANCE RANGE

50 Hz n= 2900 1/min

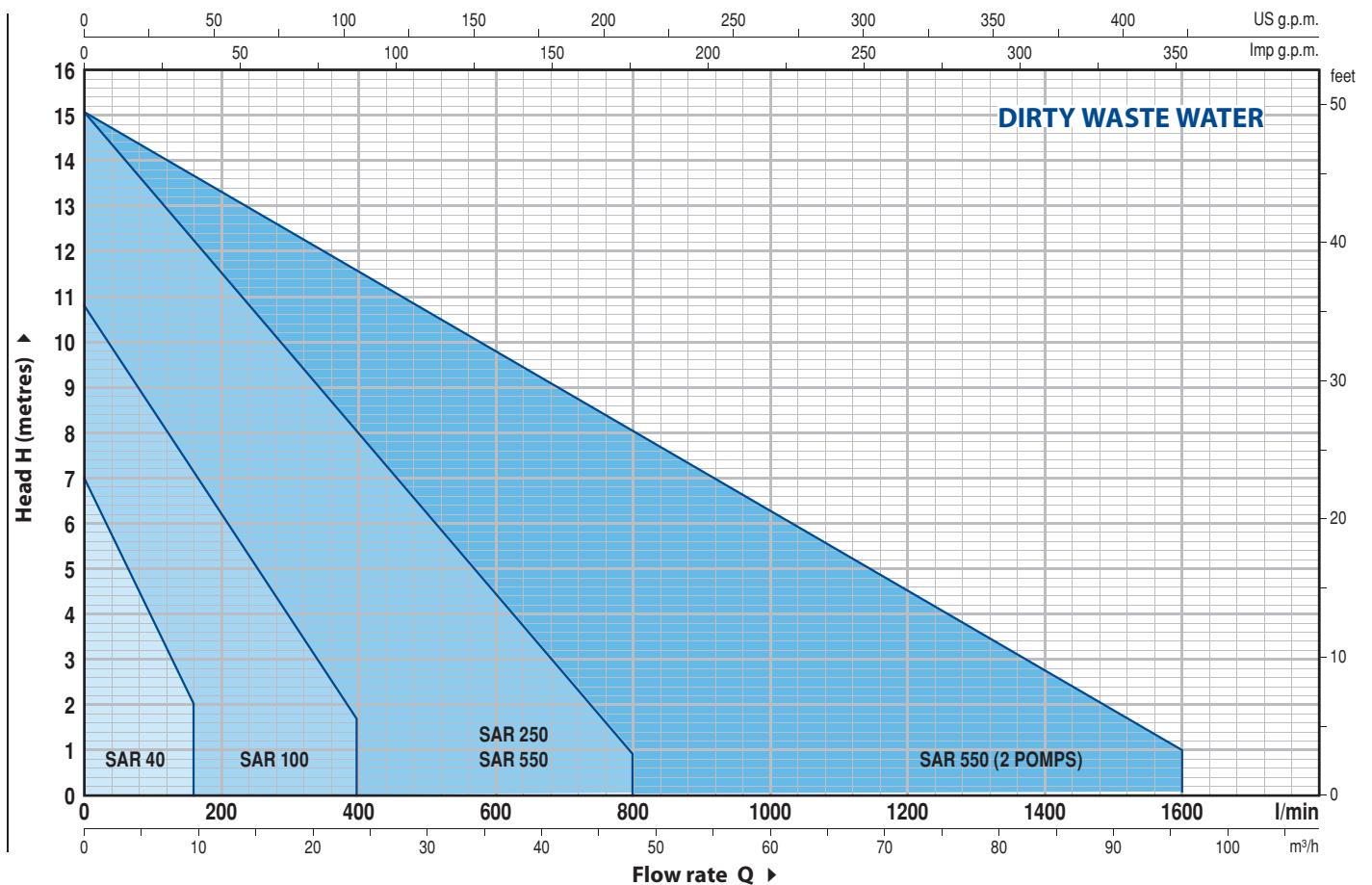

SAR 40

CLEAR WASTE WATER - RAINWATER

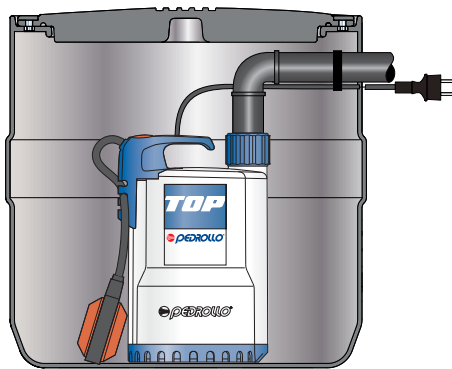

MODEL	POWER		TANK CAPACITY litres	MAXIMUM FLOW RATE l/min	MAXIMUM HEAD metres
	kW	HP			
SAR 40 - TOP1	0.25	0.33	40	160	6
SAR 40 - TOP2	0.37	0.50	40	220	8
SAR 40 - RXm1	0.25	0.33	40	160	6.5
SAR 40 - RXm2	0.37	0.50	40	220	9.5
SAR 40 - RXm3	0.55	0.75	40	220	11.5

COMPONENTS

- 40-litre polyethylene tank with cover plate
- Pump with float switch
- Power cable: **5 metres** standard issue with Schuko plug
- Non-return valve

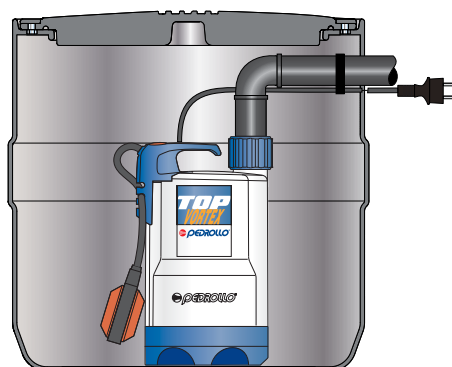

DIRTY WASTE WATER

MODEL	POWER		TANK CAPACITY litres	MAXIMUM FLOW RATE l/min	MAXIMUM HEAD metres
	kW	HP			
SAR 40 - TOP VORTEX	0.37	0.50	40	180	6.5
SAR 40 - RXm2/20	0.37	0.50	40	180	6.5

COMPONENTS

- 40-litre polyethylene tank with cover plate
- Pump with float switch
- Power cable: **5 metres** standard issue with Schuko plug
- Non-return valve

OPTIONALS AVAILABLE ON REQUEST

- Pump with 10 m long power cable.
 - ➔ Standard EN 60335-2-41 states that the power cable must be 10 m long for outdoor applications

CLEAR WASTE WATER - RAINWATER

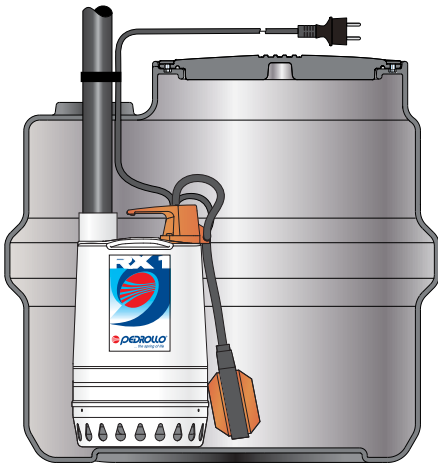

MODEL	POWER		TANK CAPACITY litres	MAXIMUM FLOW RATE l/min	MAXIMUM HEAD metres
	kW	HP			
SAR 100 - TOP1	0.25	0.33	100	160	6
SAR 100 - TOP2	0.37	0.50	100	220	8
SAR 100 - TOP3	0.55	0.75	100	260	10
SAR 100 - TOP4	0.75	1	100	320	12
SAR 100 - TOP MULTI II	0.55	0.75	100	80	35
SAR 100 - RXm1	0.25	0.33	100	160	6.5
SAR 100 - RXm2	0.37	0.50	100	220	9.5
SAR 100 - RXm3	0.55	0.75	100	220	11.5
SAR 100 - ZDm1A-E	0.50	0.70	100	250	10.5
SAR 100 - ZDm1AR-E	0.60	0.85	100	300	13.5
SAR 100 - Dm8	0.55	0.75	100	275	11.5
SAR 100 - Dm10	0.75	1	100	325	14.5
SAR 100 - Dm15	1.1	1.5	100	400	22
SAR 100 - Dm18	0.55	0.75	100	200	16.5
SAR 100 - Dm20	0.75	1	100	200	20
SAR 100 - Dm30	1.1	1.5	100	300	26

COMPONENTS

- 100-litre polyethylene tank with cover plate
- Pump with float switch
- Power cable: **5 m** (standard issue with Schuko plug)
10 m (TOP4, TOP MULTI II with Schuko plug)

DIRTY WASTE WATER



MODEL	POWER		TANK CAPACITY litres	MAXIMUM FLOW RATE l/min	MAXIMUM HEAD metres
	kW	HP			
SAR 100 - TOP VORTEX	0.37	0.50	100	180	6.5
SAR 100 - RXm2/20	0.37	0.50	100	180	6.5
SAR 100 - RXm3/20	0.55	0.75	100	180	8
SAR 100 - ZXm1A/40	0.60	0.85	100	400	10.5

COMPONENTS

- 100-litre polyethylene tank with cover plate
- Pump with float switch
- Power cable: **5 m** (standard issue with Schuko plug)

OPTIONALS AVAILABLE ON REQUEST

- Pump with **10 m** long power cable.
 - ➔ Standard EN 60335-2-41 states that the power cable must be 10 m long for outdoor applications

CLEAR WASTE WATER - RAINWATER

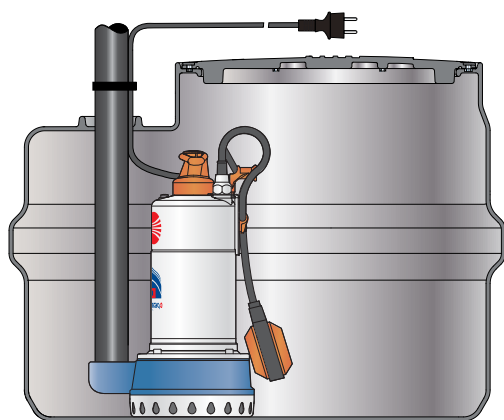

MODEL	POWER		TANK CAPACITY litres	MAXIMUM FLOW RATE l/min	MAXIMUM HEAD metres
	kW	HP			
SAR 250 - NKm2/1-GE	0.45	0.6	250	80	35
SAR 250 - TOP MULTI II	0.55	0.75	250	80	35
SAR 250 - TOP3	0.55	0.75	250	260	10
SAR 250 - TOP4	0.75	1	250	320	12
SAR 250 - TOP5	0.92	1.25	250	400	14
SAR 250 - RXm2	0.37	0.50	250	220	9.5
SAR 250 - RXm3	0.55	0.75	250	220	11.5
SAR 250 - RXm4	0.75	1	250	260	15
SAR 250 - RXm5	1.1	1.5	250	300	19.5
SAR 250 - ZDm1A-E	0.50	0.70	250	250	10.5
SAR 250 - ZDm1AR-E	0.60	0.85	250	300	13.5
SAR 250 - Dm10	0.75	1	250	325	14.5
SAR 250 - Dm15	1.1	1.5	250	400	22
SAR 250 - Dm20	0.75	1	250	200	20
SAR 250 - Dm30	1.1	1.5	250	300	26

COMPONENTS

- 250-litre polyethylene tank with cover plate
- Pump with float switch
- Power cable: **5 m** (standard issue with Schuko plug)
10 m (TOP MULTI II, TOP4-5, RXm4-5 with Schuko plug)
20 m (NKm2/1-GE without Schuko plug)

OPTIONALS AVAILABLE ON REQUEST

- Pump with **10 m** long power cable.
 - ➔ Standard EN 60335-2-41 states that the power cable must be 10 m long for outdoor applications

Extension kit

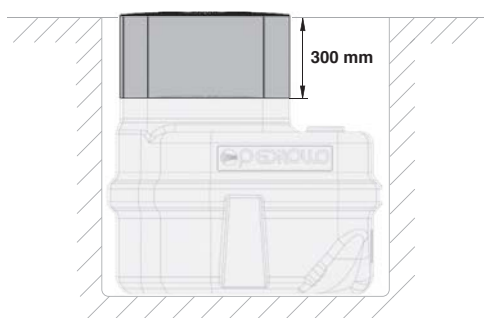

OPTIONALS AVAILABLE ON REQUEST

"TYPE A" 300 mm extension KIT

The kit consists of an extension for the installation of the tank at greater depths

Alarm KIT

The kit consists of a float switch, self powered alarm, control box

DIRTY WASTE WATER

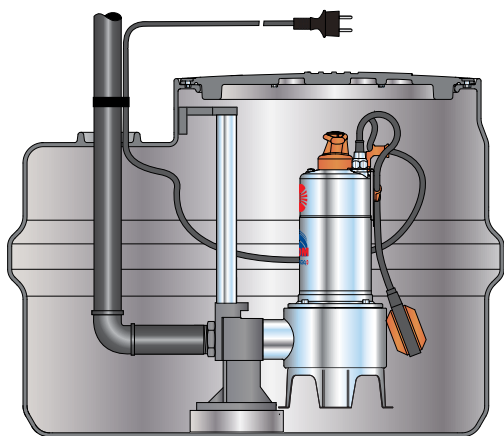

MODEL	POWER		TANK CAPACITY litres	MAXIMUM FLOW RATE l/min	MAXIMUM HEAD metres
	kW	HP			
SAR 250 - TOP VORTEX	0.37	0.50	250	180	6.5
SAR 250 - RXm3/20	0.55	0.75	250	180	8
SAR 250 - RXm4/40	0.75	1	250	280	9.5
SAR 250 - RXm5/40	1.1	1.5	250	380	12.5
SAR 250 - ZXm1A/40	0.60	0.85	250	400	10.5
SAR 250 - VXm10/35	0.75	1	250	300	9.5
SAR 250 - VXm15/35	1.1	1.5	250	450	14
SAR 250 - VXm10/50	0.75	1	250	400	7
SAR 250 - VXm15/50	1.1	1.5	250	500	10.5
SAR 250 - MCm10/50	0.75	1	250	500	10.7
SAR 250 - MCm12/50	1.1	1.5	250	800	14
SAR 250 - VXm10/35-I	0.75	1	250	300	9.5
SAR 250 - VXm10/50-I	0.75	1	250	400	7
SAR 250 - MCm10/50-I	0.75	1	250	500	10.7

COMPONENTS

- 250-litre polyethylene tank with cover plate
- Pump with float switch
- Power cable: **5 m** (standard issue with Schuko plug)
10 m (RXm4-5/40 with Schuko plug)
- Lowering device (only for VX-I and MC-I versions)

OPTIONALS AVAILABLE ON REQUEST

- Pump with **10 m** long power cable.
 - ⇒ Standard EN 60335-2-41 states that the power cable must be 10 m long for outdoor applications

Extension kit

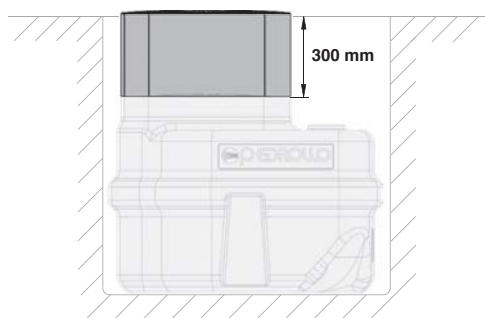

OPTIONALS AVAILABLE ON REQUEST

"TYPE A" 300 mm extension KIT

The kit consists of an extension for the installation of the tank at greater depths

"TYPE B" 300 mm extension KIT for VX-I and MC-I series pumps

The kit consists of an extension for the installation of the tank at greater depths and (longer) guide tubes for lowering the pump

Alarm KIT

The kit consists of a float switch, self powered alarm, control box

Base pedestal elbow (duct foot)

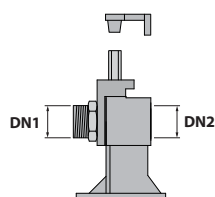

MODEL	PUMP	PORTS	
		DN1	DN2
PA/1	VX /35-I	1½"	2"
PA/2	VX /50-I and MC/50-I	2"	

CLEAR WASTE WATER - RAINWATER

MODEL	POWER		TANK CAPACITY litres	MAXIMUM FLOW RATE (1 pump) l/min	MAXIMUM HEAD metres
	kW	HP			
SAR 550 - NKm 2/1	0.45	0.6	550	80	35
SAR 550 - TOP MULTI II	0.55	0.75	550	80	35
SAR 550 - TOP3	0.55	0.75	550	260	10
SAR 550 - TOP4	0.75	1	550	320	12
SAR 550 - TOP5	0.92	1.25	550	400	14
SAR 550 - RXm2	0.37	0.50	550	220	9.5
SAR 550 - RXm3	0.55	0.75	550	220	11.5
SAR 550 - RXm4	0.75	1	550	260	15
SAR 550 - RXm5	1.1	1.5	550	300	19.5
SAR 550 - ZDm 1A-E	0.50	0.70	550	250	10.5
SAR 550 - ZDm 1AR-E	0.60	0.85	550	300	13.5
SAR 550 - Dm10	0.75	1	550	325	14.5
SAR 550 - Dm15	1.1	1.5	550	400	22
SAR 550 - Dm20	0.75	1	550	200	20
SAR 550 - Dm30	1.1	1.5	550	300	26

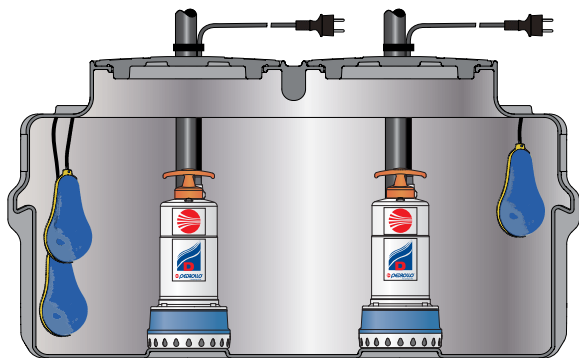

COMPONENTS

- 550-litre polyethylene tank with two cover plates
- Two single-phase pumps
- Control panel
- Three float switches for:
 - 1) the alternate start-up of one of the two pumps
 - 2) maximum level for starting-up the second pump
 - 3) minimum level for switching the pumps off

OPTIONALS AVAILABLE ON REQUEST

- Pump with 10 m long power cable.
 - ➔ Standard EN 60335-2-41 states that the power cable must be 10 m long for outdoor applications

OPTIONALS AVAILABLE ON REQUEST

"TYPE A" 300 mm extension KIT

The kit consists of an extension for the installation of the tank at greater depths

Alarm KIT

The kit consists of a float switch, self powered alarm, control box

Extension kit

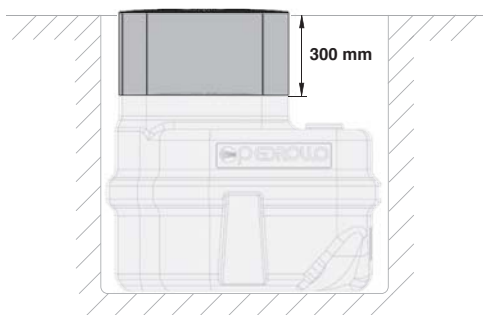

DIRTY WASTE WATER

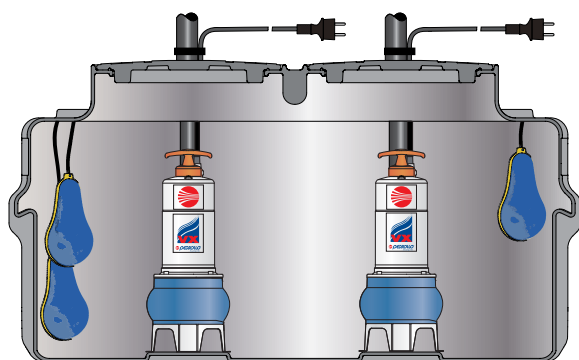

MODEL	POWER		TANK CAPACITY litres	MAXIMUM FLOW RATE (1 pump) l/min	MAXIMUM HEAD metres
	kW	HP			
SAR 550 - RXm 3/20	0.55	0.75	550	180	8
SAR 550 - RXm 4/40	0.75	1	550	280	9.5
SAR 550 - RXm 5/40	1.1	1.5	550	380	12.5
SAR 550 - ZXm 1A/40	0.60	0.85	550	400	10.5
SAR 550 - VXm 10/35	0.75	1	550	300	9.5
SAR 550 - VXm 15/35	1.1	1.5	550	450	14
SAR 550 - VXm 10/50	0.75	1	550	400	7
SAR 550 - VXm 15/50	1.1	1.5	550	500	10.5
SAR 550 - MCm 10/50	0.75	1	550	500	10.7
SAR 550 - MCm 12/50	1.1	1.5	550	800	14
SAR 550 - VXm 10/35-I	0.75	1	550	300	9.5
SAR 550 - VXm 10/50-I	0.75	1	550	400	7
SAR 550 - MCm 10/50-I	0.75	1	550	500	10.7

COMPONENTS

- 550-litre polyethylene tank with cover plate
- **Two single-phase pumps**
- **Two single-phase pumps**
- Control panel
- Three float switches for:
 - 1) the alternate start-up of one of the two pumps
 - 2) maximum level for starting-up the second pump
 - 3) minimum level for switching the pumps off
- Lowering device (only for VX-I and MC-I versions)

OPTIONALS AVAILABLE ON REQUEST

- Pump with **10 m** long power cable.
 - ➡ Standard EN 60335-2-41 states that the power cable must be 10 m long for outdoor applications

Extension kit

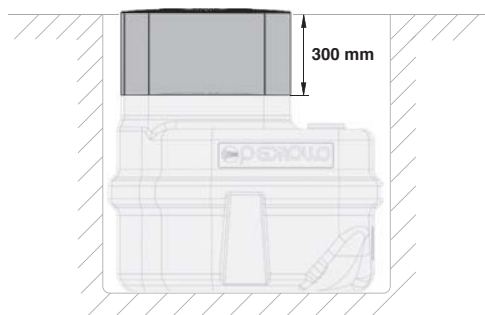

OPTIONALS AVAILABLE ON REQUEST

"TYPE A" 300 mm extension KIT

The kit consists of an extension for the installation of the tank at greater depths

"TYPE B" 300 mm extension KIT for VX-I and MC-I series pumps

The kit consists of an extension for the installation of the tank at greater depths and (longer) guide tubes for lowering the pump

Alarm KIT

The kit consists of a float switch, self powered alarm, control box

Base pedestal elbow (duct foot)

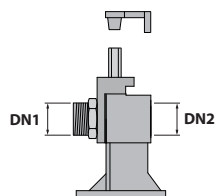

MODEL	POMP	PORTS	
		DN1	DN2
PA/1	VX /35-I	1½"	2"
PA/2	VX /50-I and MC/50-I	2"	

DIMENSIONS AND WEIGHT

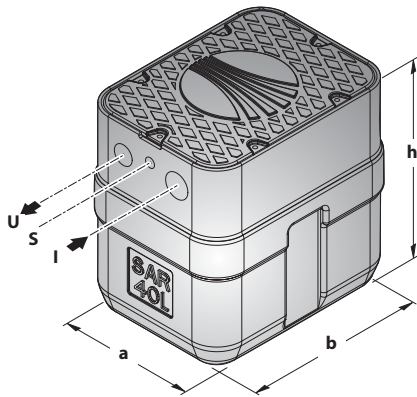

MODEL	PORTS			DIMENSIONS mm			kg
	I	U	S	a	b	h	
SAR 40 - TOP1	1½"	1¼"	½"	310	410	410	14.0
SAR 40 - TOP2							14.7
SAR 40 - RXm1							14.2
SAR 40 - RXm2							15.3
SAR 40 - RXm3							15.6
SAR 40 - TOP-VORTEX							14.6
SAR 40 - RXm 2/20							15.6

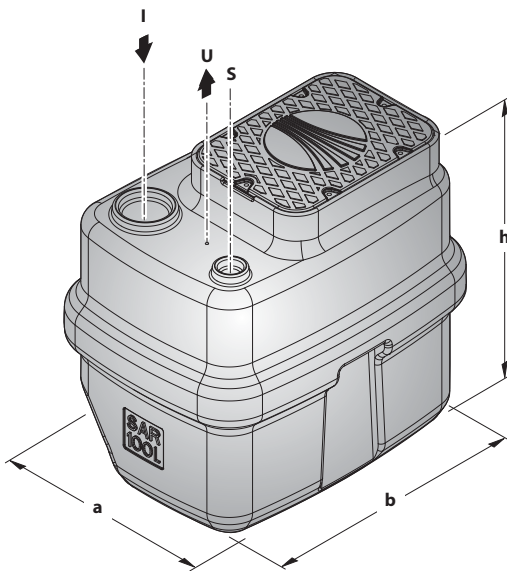

MODEL	PORTS			DIMENSIONS mm			kg
	I	U	S	a	b	h	
SAR 100 - TOP1	Ø 100 mm	1¼"	Ø 50 mm	500	690	645	28.0
SAR 100 - TOP2							28.7
SAR 100 - TOP3							30.1
SAR 100 - TOP4							33.6
SAR 100 - TOP MULTI II							32.9
SAR 100 - RXm1							28.2
SAR 100 - RXm2							29.3
SAR 100 - RXm3							29.6
SAR 100 - ZDm 1A-E							35.0
SAR 100 - ZDm 1AR-E							35.3
SAR 100 - Dm8		35.2					
SAR 100 - Dm10		36.2					
SAR 100 - Dm15		38.2					
SAR 100 - Dm18		35.3					
SAR 100 - Dm20		36.5					
SAR 100 - Dm30		38.5					
SAR 100 - TOP-VORTEX		28.6					
SAR 100 - RXm 2/20		29.6					
SAR 100 - RXm 3/20		29.8					
SAR 100 - ZXm 1A/40		35.2					

DIMENSIONS AND WEIGHT

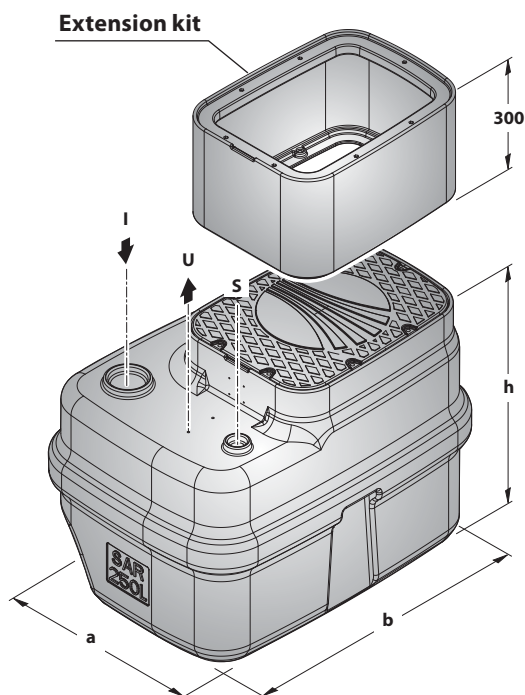

MODEL	PORTS			DIMENSIONS mm			kg
	I	U	S	a	b	h	
SAR 250 - NKm 2/1-GE	Ø100 mm			700	970	715	49.9
SAR 250 - TOP MULTI II		1/4"					45.4
SAR 250 - TOP3							42.6
SAR 250 - TOP4		1/2"					46.1
SAR 250 - TOP5							47.1
SAR 250 - RXm2		1/4"					41.8
SAR 250 - RXm3							42.1
SAR 250 - RXm4							48.7
SAR 250 - RXm5							49.7
SAR 250 - ZDm 1A-E		1/2"					47.5
SAR 250 - ZDm 1AR-E							47.8
SAR 250 - Dm10							48.7
SAR 250 - Dm15							50.7
SAR 250 - Dm20							49.0
SAR 250 - Dm30							51.0
SAR 250 - TOP-VORTEX		1/4"					41.1
SAR 250 - RXm 3/20							42.3
SAR 250 - RXm 4/40							49.0
SAR 250 - RXm 5/40							50.0
SAR 250 - ZXm 1A/40		1/2"					47.7
SAR 250 - VXm 10/35							49.3
SAR 250 - VXm 15/35							52.3
SAR 250 - VXm 10/50							49.9
SAR 250 - VXm 15/50		2"					53.0
SAR 250 - MCm 10/50							50.1
SAR 250 - MCm 12/50							53.0
SAR 250 - VXm 10/35-I		1/2"					55.8
SAR 250 - VXm 10/50-I							55.6
SAR 250 - MCm 10/50-I	2"		55.9				

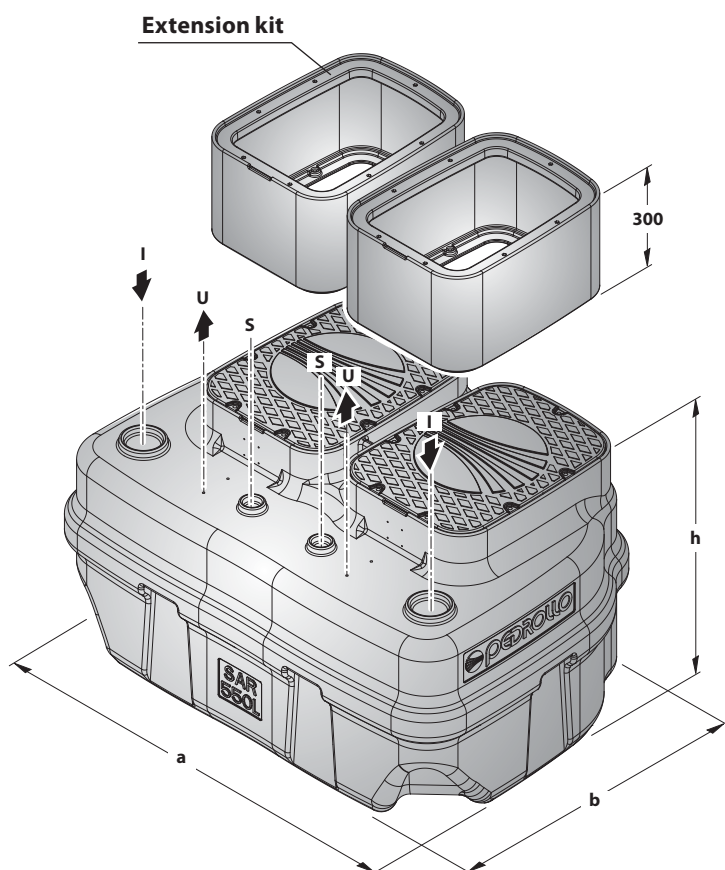

MODEL	PORTS			DIMENSIONS mm			kg
	I	U	S	a	b	h	
SAR 550 - NKm 2/1	Ø 100 mm			970	1350	715	100.8
SAR 550 - TOP MULTI II		1/4"					91.8
SAR 550 - TOP3							86.2
SAR 550 - TOP4		1/2"					93.2
SAR 550 - TOP5							95.2
SAR 550 - RXm2		1/4"					84.6
SAR 550 - RXm3							85.2
SAR 550 - RXm4							98.4
SAR 550 - RXm5							100.4
SAR 550 - ZDm 1A-E		1/2"					96.0
SAR 550 - ZDm 1AR-E							96.6
SAR 550 - Dm10							98.4
SAR 550 - Dm15							102.4
SAR 550 - Dm20							99.0
SAR 550 - Dm30							103.0
SAR 550 - RXm 3/20		1/4"					85.6
SAR 550 - RXm 4/40							99.0
SAR 550 - RXm 5/40							101.0
SAR 550 - ZXm 1A/40		1/2"					96.4
SAR 550 - VXm 10/35							99.6
SAR 550 - VXm 15/35							105.6
SAR 550 - VXm 10/50							100.8
SAR 550 - VXm 15/50		2"					107.0
SAR 550 - MCm 10/50							101.2
SAR 550 - MCm 12/50							107.0
SAR 550 - VXm 10/35-I		1/2"					109.6
SAR 550 - VXm 10/50-I							109.2
SAR 550 - MCm 10/50-I		2"					109.8

EASYPRESS

Electronic pump controllers



PERFORMANCE RANGE

- Max flow rate: **200 l/min** (12 m³/h)
- Working pressure: **10 bar**
- Start-up pressure: **1.5 bar** ●

APPLICATION LIMITS

- Maximum liquid temperature **+65 °C**
- Ambient temperature up to **+40 °C**
- Burst pressure **> 40 bar**
- Protection: **IP 65**
- VOLTAGE: **230 V** - Frequency: **50/60 Hz**
- Max current: – **10 A** EASYPRESS I
– **16 A** EASYPRESS II

CONSTRUCTION AND SAFETY STANDARDS

- The easy to replace, resin sealed circuit board offers complete protection from the effects of humidity and is housed in an IP 65 case.
- The EASYPRESS circuit board has passed the most stringent EMC tests for electromagnetic compatibility (low interference emission and high disturbance immunity), guaranteeing reliable operation in any environment.

CERTIFICATIONS



INSTALLATION AND USE

The EASYPRESS series consists of electronic devices designed to start (when a tap is turned on) and stop (when a tap is turned off) single-phase pumps.

The **microprocessor protects** the pump from dangerous working conditions, such as dry running, and allows the pump to be restarted either automatically or manually. It also prevents the pump from starting-up too often when small leaks are present within an installation.

PATENTS - TRADE MARKS - MODELS

- Registered Community Design n° 868062
- Patent Pending n° BO2008A000155, BO2008A000156
- EASYPRESS® is a registered trade mark

OPTIONALS AVAILABLE ON REQUEST

- Version with **0.8 bar** start-up pressure ●
- Version with **2.2 bar** start-up pressure ●
- Version with pressure gauge
- Version with 1" NPT ports
- Version with cable and Schuko plug and socket

GUARANTEE

1 year subject to terms and conditions

START-UP PRESSURE

There are **three different models** available to choose from, **each with a different start-up pressure** and easily identified by the **coloured cap** positioned at the rear of EASYPRESS, suitable for delivering supply to different heights.

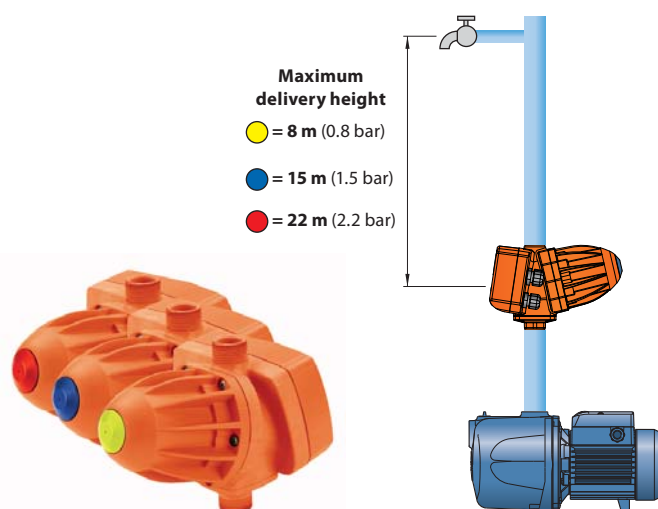

PRESSURE LOSSES

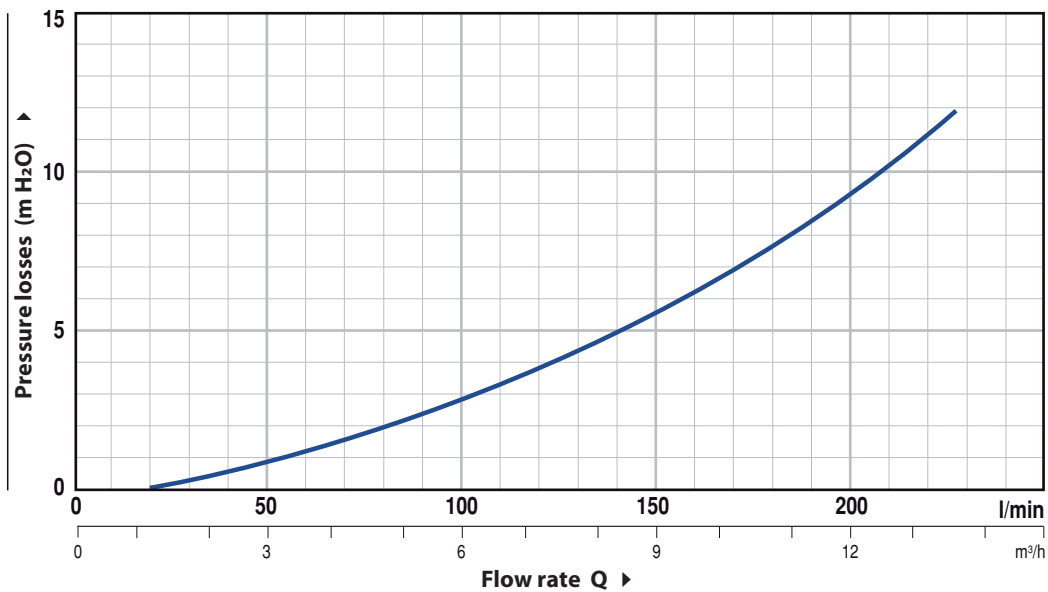

MODEL	Power		Volt	Hz	Current	Fittings	Flow rate	Start-up pressure
	kW	HP						
EASYPRESS I	0.75	1	230	50/60	10 A	1" x 1"	12 m ³ /h	1.5 bar
EASYPRESS II	1.5	2	230	50/60	16 A	1" x 1"	12 m ³ /h	1.5 bar

DIMENSIONS AND WEIGHT

MODEL	PORTS		DIMENSIONS mm			kg
	a	b	c	d	h	
EASYPRESS I-II	1"	1"	221	174	174	1.63

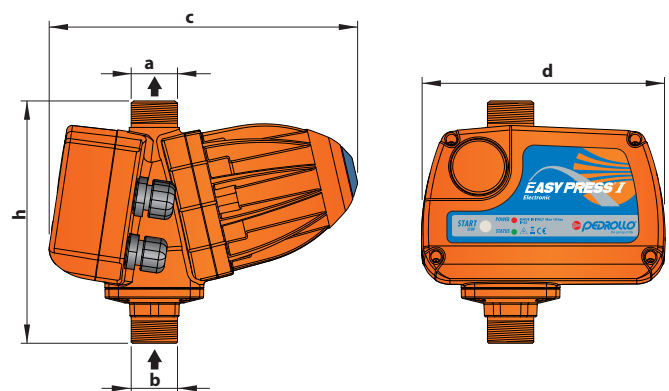

Quick-fit joint with o-ring

MODEL	FITTING
GSR	1" M



PALLETIZATION

MODEL	n°	H (mm)	kg
Single-phase EASYPRESS I-II	147	1450	257

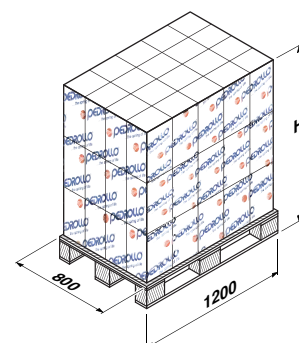

EASYPRO

Electronic pump controller



PERFORMANCE RANGE

- Max flow rate: **200 l/min** (12 m³/h)
- Working pressure: **10 bar**
- Start-up pressure: values between **1 and 5 bar**

APPLICATION LIMITS

- Maximum liquid temperature **+65 °C**
- Ambient temperature up to **+40 °C**
- Burst pressure: **> 40 bar**
- Protection: **IP 65**
- Voltage: **230 V** - Frequency: **50/60 Hz** - Max current: **16 A**

CONSTRUCTION AND SAFETY STANDARDS

- Easy to replace, resin sealed circuit board for complete protection from the effects of humidity.
- The pressure sensor is housed in a separate area, isolated from the circuit board and current carrying components.
- The EASYPRO circuit board has passed the most stringent EMC tests for electromagnetic compatibility (low interference emission and high disturbance immunity), guaranteeing reliable operation in any environment.

CERTIFICATIONS



GUARANTEE

1 year subject to terms and conditions

INSTALLATION AND USE

EASYPRO® differs from traditional PRESSURE-FLOW REGULATORS as a result of the following innovative characteristics:

- **the built-in surge tank;**
- the possibility to **select** the pump start-up (re-start) pressure;
- the **back-lit LCD display** where the pressure and other useful information is indicated.

PUMP START-UP PRESSURE

EASYPRO makes it possible to select the pump start-up (re-start) pressure between the values of **1 and 5 bar**.

The pressure selection is made using the command button and by following the instructions that appear on the LCD display.

A single model is capable of covering a wide range of installation requirements.

SURGE TANK

EASYPRO® comes complete with a built-in **3 litre** surge tank.

The substantial accumulation volume combined with its ability to absorb over-pressure, a typical surge tank characteristic, make it suitable for use in installations where other pressure-flow regulators may prove inadequate.

In order to guarantee optimum protection and accumulator performance, it is possible to adjust the tank pressure, the **factory setting is 1.8 bar**, to suit the pump start pressure selected.

PATENTS - TRADE MARKS - MODELS

- Registered Community Design n° 976824
- Patent Pending n° BO2008A000155, BO2008A000156
- EASYPRO® is a registered trade mark

OPTIONALS AVAILABLE ON REQUEST

- Version with 1" NPT ports
- Version with cable and Schuko plug and socket

PRESSURE LOSSES

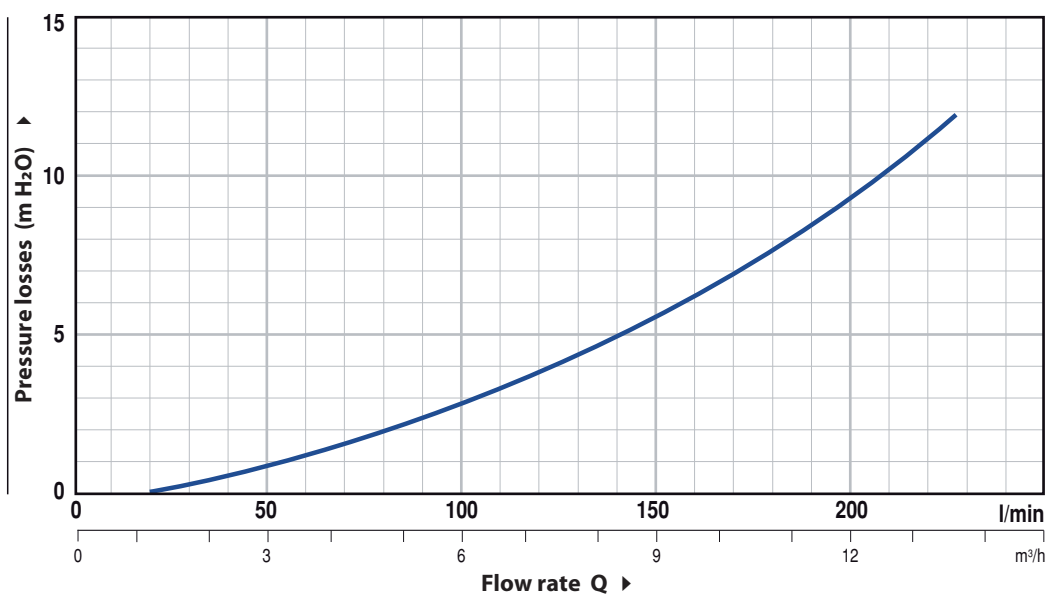

MODEL	Power		Volt	Hz	Current	Fittings	Flow rate	Variable start-up pressure
	kW	HP						
EASYPRO	1.5	2	230	50/60	16 A	1" x 1"	12 m ³ /h	1÷5 bar

DIMENSIONS AND WEIGHT

MODEL	PORTS		DIMENSIONS mm				kg
	a	b	c	d	e	h	
EASYPRO	1"	1"	283	162	192	174	2.43

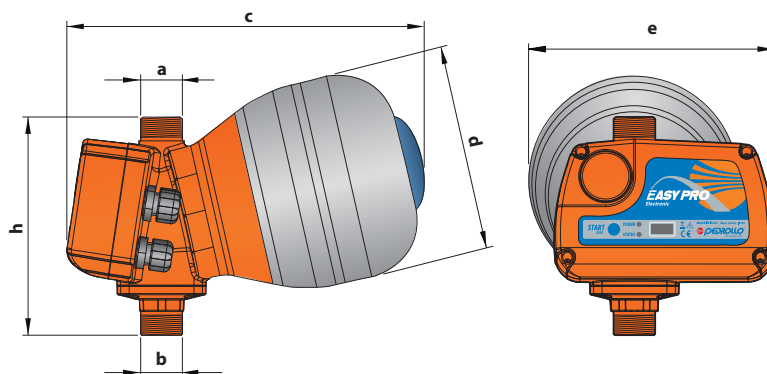

Quick-fit joint with o-ring

MODEL	FITTING
GSR	1" M



PALLETIZATION

MODEL	n°	H (mm)	kg
Single-phase			
EASYPRO	98	1450	255

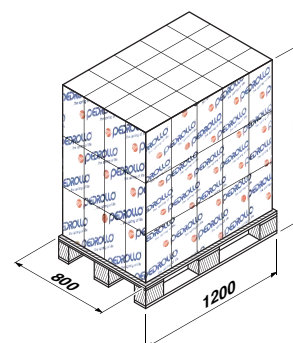



PUMPS WITH EASYPRESS I



- Pumps complete with EASYPRESS programmed to start and stop the pumps as a tap is turned on or off.
- Regulates flow rate and pressure, keeping them constant
- Assures that the pump is stopped in the event of a lack of water.

MODEL	POWER	
	kW	HP
Single-phase		
PK series pumps		
PKm 60 - EP I	0.37	0.50
PKm 65 - EP I	0.50	0.70
PKm 70 - EP I	0.60	0.85
CP series pumps		
CPm 158 - EP I	0.75	1
2CP series pumps		
2CPm 25/130N - EP I	0.75	1
2÷4CP series pumps		
2CPm 80E - EP I	0.37	0.50
3CPm 80E - EP I	0.45	0.60
4CPm 80E - EP I	0.60	0.85
3CPm 100E - EP I	0.60	0.85
4CPm 100E - EP I	0.75	1
JSW series pumps		
JSWm 1C - EP I	0.37	0.50
JSWm 1B - EP I	0.50	0.70
JSWm 1A - EP I	0.60	0.85
JSWm 10H - EP I	0.75	1
JSWm 12H - EP I	0.90	1.25
JSWm 10M - EP I	0.75	1
JSWm 12M - EP I	0.90	1.25

PUMPS WITH EASYPRESS II



MODEL	POWER	
	kW	HP
Single-phase		
CP series pumps		
CPm 170 - EP II	1.1	1.5
2CP series pumps		
2CPm 25/140H - EP II	1.1	1.5
2CPm 25/140M - EP II	1.1	1.5
JSW series pumps		
JSWm 15H - EP II	1.1	1.5
JSWm 15M - EP II	1.1	1.5

- Use EASYPRESS II from 1.5 HP (1.1 kW) up

Pumps with pressure switch sub-assembly



PUMP MODELS COMPLETE WITH PRESSURE SWITCH SUB-ASSEMBLY



- Pumps with pressure switch sub-assembly ready for connection to a pressure vessel.

MODEL	PORTS		POWER		FLOW RATE	SETTING
	asp.	mand.	kW	HP	(1) Q l/min	(2) bar

Single-phase

PK series pumps

PKm 60 - PR	1"	1"	0.37	0.50	32	1.4 ÷ 2.8
PKm 65 - PR	1"	1"	0.50	0.70	40	1.5 ÷ 3.0

CP series pumps

CPm 158 - PR	1"	1"	0.75	1	90	2.2 ÷ 3.6
--------------	----	----	------	---	----	-----------

2CP series pumps

2CPm 25/130N - PR	1¼"	1"	0.75	1	100	1.4 ÷ 2.8
2CPm 25/140H - PR	1¼"	1"	1.1	1.5	100	2.5 ÷ 4.0

2÷4CP series pumps

2CPm 80E - PR	1"	1"	0.37	0.50	50	1.0 ÷ 2.2
3CPm 80E - PR	1"	1"	0.45	0.60	60	1.4 ÷ 2.8
4CPm 80E - PR	1"	1"	0.60	0.85	60	2.2 ÷ 3.6
3CPm 100E - PR	1"	1"	0.60	0.85	100	1.4 ÷ 2.8
4CPm 100E - PR	1"	1"	0.75	1	100	2.0 ÷ 3.5

JSW series pumps

JSWm 1C - PR	1"	1"	0.37	0.50	45	1.2 ÷ 2.6
JSWm 1B - PR	1"	1"	0.50	0.70	50	1.4 ÷ 2.8
JSWm 1A - PR	1"	1"	0.60	0.85	50	1.8 ÷ 3.2
JSWm 10H - PR	1"	1"	0.75	1	50	2.0 ÷ 3.2
JSWm 12H - PR	1"	1"	0.90	1.25	50	2.5 ÷ 4.0
JSWm 15H - PR	1"	1"	1.1	1.5	50	3.0 ÷ 4.5
JSWm 10M - PR	1"	1"	0.75	1	80	1.4 ÷ 2.8
JSWm 12M - PR	1"	1"	0.90	1.25	80	2.0 ÷ 3.5
JSWm 15M - PR	1"	1"	1.1	1.5	80	2.5 ÷ 4.0
JSWm 3CH - PR	1¼"	1"	1.1	1.5	70	3.0 ÷ 4.5
JSWm 3CM - PR	1¼"	1"	1.1	1.5	120	2.0 ÷ 3.5
JSWm 3CL - PR	1¼"	1"	1.1	1.5	160	1.4 ÷ 2.8

JCR series pumps

JCRm 1C - PR	1"	1"	0.37	0.50	50	1.2 ÷ 2.6
JCRm 1B - PR	1"	1"	0.50	0.70	50	1.4 ÷ 2.8
JCRm 1A - PR	1"	1"	0.60	0.85	50	1.8 ÷ 3.2
JCRm 10H - PR	1¼"	1"	0.75	1	50	2.0 ÷ 3.4
JCRm 15H - PR	1¼"	1"	1.1	1.5	50	3.0 ÷ 4.0
JCRm 10M - PR	1¼"	1"	0.75	1	80	1.4 ÷ 2.8
JCRm 15M - PR	1¼"	1"	1.1	1.5	80	2.5 ÷ 4.0

- (1) Maximum flow rate at the recommended minimum pressure switch pressure
 (2) Pressure switch setting (recommended)

24SF

Small pressure sets "HYDROFRESH"



Small, automatic pressure sets with a 24 litre spherical tank suitable for the distribution of pressurised water in domestic applications



PERFORMANCE

MODEL	POWER	FLOW RATE	SETTING		
			(1)	(2)	
brass / stainless steel impeller	technopolymer impeller	kW	HP	l/min	bar

PK series pumps

PKm 60 - 24 SF	-	0.37	0.50	32	1.4 ÷ 2.8
PKm 65 - 24 SF	-	0.50	0.70	40	1.5 ÷ 3.0
PKm 70 - 24 SF	-	0.60	0.85	50	1.8 ÷ 3.2

CP series pumps

CPm 158 - 24 SF	CPm 158X - 24 SF	0.75	1	90	1.8 ÷ 3.2
CPm 170 - 24 SF	CPm 170X - 24 SF	1.1	1.5	120	2.2 ÷ 3.5

2CP series pumps

2CPm 25/130N - 24 SF	2CPm 25/130NX - 24 SF	0.75	1	100	1.4 ÷ 2.8
----------------------	-----------------------	------	---	-----	-----------

JSW series pumps

JSWm 1C - 24 SF	JSWm 1CX - 24 SF	0.37	0.50	45	1.2 ÷ 2.6
JSWm 1B - 24 SF	JSWm 1BX - 24 SF	0.50	0.70	50	1.4 ÷ 2.8
JSWm 1A - 24 SF	JSWm 1AX - 24 SF	0.60	0.85	50	1.8 ÷ 3.2
JSWm 10H - 24 SF	JSWm 10HX - 24 SF	0.75	1	50	2.0 ÷ 3.2
JSWm 12H - 24 SF	JSWm 12HX - 24 SF	0.90	1.25	50	2.5 ÷ 4.0
JSWm 15H - 24 SF	JSWm 15HX - 24 SF	1.1	1.5	50	3.0 ÷ 4.5
JSWm 3CH - 24 SF	-	1.1	1.5	70	3.0 ÷ 4.5

➔ (1) Pressure switch setting (recommended)

➔ (2) Maximum flow rate at the minimum recommended pressure switch pressure

N.B. The pressure in the vessel should be pre-set to a value 0.2 bar lower than the recommended minimum setting of the pressure switch.

24SF COMPONENTS:

- Single phase pump
- 24 litre spherical tank
- Pressure switch
- Pressure gauge
- Brass connector
- 1.5 metres power cable with Schuko plug

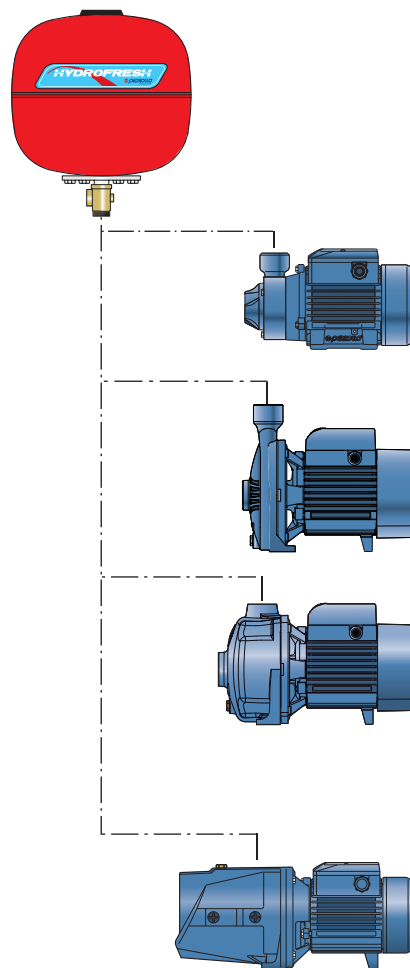

Small pressure sets "HYDROFRESH"



Small, automatic pressure sets with a 20 litre cylindrical tank suitable for the distribution of pressurised water in domestic applications.



PERFORMANCE

MODEL		POWER		FLOW RATE	SETTING
brass / stainless steel impeller	technopolymer impeller	kW	HP	(2) l/min	(1) bar
PK series pumps					
PKm 60 - 24 CL	-	0.37	0.50	32	1.4 ÷ 2.8
PKm 65 - 24 CL	-	0.50	0.70	40	1.5 ÷ 3.0
PKm 70 - 24 CL	-	0.60	0.85	50	1.8 ÷ 3.2
CP series pumps					
CPm 158 - 24 CL	CPm 158X - 24 CL	0.75	1	90	1.8 ÷ 3.2
CPm 170 - 24 CL	CPm 170X - 24 CL	1.1	1.5	120	2.2 ÷ 3.5
2÷4CP series pumps					
-	3CPm 80E - 24 CL	0.45	0.60	60	1.4 ÷ 2.8
-	4CPm 80E - 24 CL	0.60	0.85	60	2.2 ÷ 3.6
-	3CPm 100E - 24 CL	0.60	0.85	100	1.4 ÷ 2.8
-	4CPm 100E - 24 CL	0.75	1	100	2.0 ÷ 3.5
JSW series pumps					
JSWm 1C - 24 CL	JSWm 1CX - 24 CL	0.37	0.50	45	1.2 ÷ 2.6
JSWm 1B - 24 CL	JSWm 1BX - 24 CL	0.50	0.70	50	1.4 ÷ 2.8
JSWm 1A - 24 CL	JSWm 1AX - 24 CL	0.60	0.85	50	1.8 ÷ 3.2
JSWm 10H - 24 CL	JSWm 10HX - 24 CL	0.75	1	50	2.0 ÷ 3.2
JSWm 12H - 24 CL	JSWm 12HX - 24 CL	0.90	1.25	50	2.5 ÷ 4.0
JSWm 15H - 24 CL	JSWm 15HX - 24 CL	1.1	1.5	50	3.0 ÷ 4.5
JSWm 10M - 24 CL	JSWm 10MX - 24 CL	0.75	1	80	1.4 ÷ 2.8
JSWm 12M - 24 CL	JSWm 12MX - 24 CL	0.90	1.25	80	2.0 ÷ 3.5
JSWm 15M - 24 CL	JSWm 15MX - 24 CL	1.1	1.5	80	2.5 ÷ 4.0
JSWm 3CH - 24 CL	-	1.1	1.5	70	3.0 ÷ 4.5
JCR series pumps					
-	JCRm 1C - 24 CL	0.37	0.50	50	1.2 ÷ 2.6
-	JCRm 1B - 24 CL	0.50	0.70	50	1.4 ÷ 2.8
-	JCRm 1A - 24 CL	0.60	0.85	50	1.8 ÷ 3.2
-	JCRm 10H - 24 CL	0.75	1	50	2.0 ÷ 3.4
-	JCRm 15H - 24 CL	1.1	1.5	50	3.0 ÷ 4.0
-	JCRm 10M - 24 CL	0.75	1	80	1.4 ÷ 2.8
-	JCRm 15M - 24 CL	1.1	1.5	80	2.5 ÷ 4.0

-	JCRm 1C - 24 CL	0.37	0.50	50	1.2 ÷ 2.6
-	JCRm 1B - 24 CL	0.50	0.70	50	1.4 ÷ 2.8
-	JCRm 1A - 24 CL	0.60	0.85	50	1.8 ÷ 3.2
-	JCRm 10H - 24 CL	0.75	1	50	2.0 ÷ 3.4
-	JCRm 15H - 24 CL	1.1	1.5	50	3.0 ÷ 4.0
-	JCRm 10M - 24 CL	0.75	1	80	1.4 ÷ 2.8
-	JCRm 15M - 24 CL	1.1	1.5	80	2.5 ÷ 4.0

- ➔ (1) Pressure switch setting (recommended)
- ➔ (2) Maximum flow rate at the minimum recommended pressure switch pressure

N.B. The pressure in the vessel should be pre-set to a value 0.2 bar lower than the recommended minimum setting of the pressure switch.

24 CL COMPONENTS:

- Single phase pump
- 20 litre spherical tank
- Hose
- Pressure switch
- Pressure gauge
- Brass connector
- 1.5 metres power cable with Schuko plug

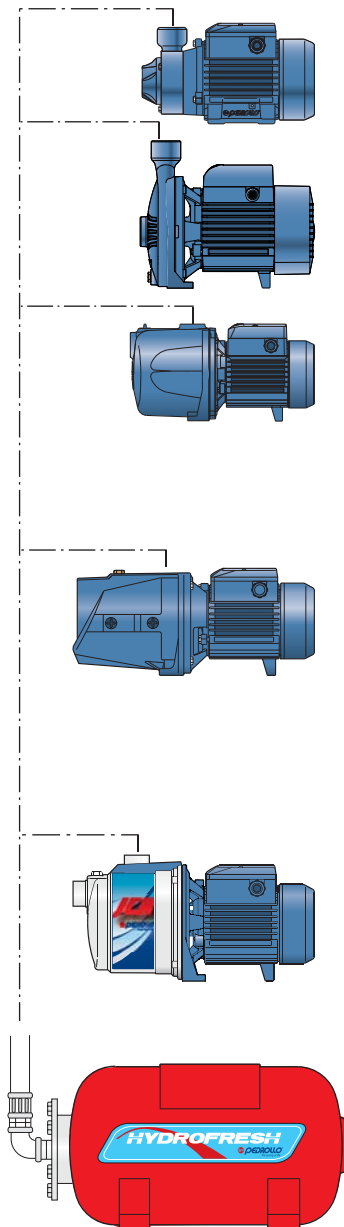

60CL

Pressure sets "HYDROFRESH"



Automatic pressure sets with a 60 litre spherical tank suitable for the distribution of pressurised water in domestic applications.



PERFORMANCE

MODEL		POWER		FLOW RATE	SETTING
brass / stainless steel impeller	technopolymer impeller	kW	HP	(2) l/min	(1) bar
CP series pumps					
CPm 158 - 60 CL	CPm 158X - 60 CL	0.75	1	90	1.8 ÷ 3.2
CPm 170 - 60 CL	CPm 170X - 60 CL	1.1	1.5	120	2.2 ÷ 3.5
2CP series pumps					
2CPm 25/130N - 60 CL	2CPm 25/130NX - 60 CL	0.75	1	100	1.4 ÷ 2.8
2CPm 25/140H - 60 CL	2CPm 25/140HX - 60 CL	1.1	1.5	100	2.2 ÷ 3.6
JSW series pumps					
JSWm 10H - 60 CL	JSWm 10HX - 60 CL	0.75	1	50	2.0 ÷ 3.2
JSWm 12H - 60 CL	JSWm 12HX - 60 CL	0.90	1.25	50	2.5 ÷ 4.0
JSWm 15H - 60 CL	JSWm 15HX - 60 CL	1.1	1.5	50	3.0 ÷ 4.5
JSWm 10M - 60 CL	JSWm 10MX - 60 CL	0.75	1	80	1.4 ÷ 2.8
JSWm 12M - 60 CL	JSWm 12MX - 60 CL	0.90	1.25	80	2.0 ÷ 3.5
JSWm 15M - 60 CL	JSWm 15MX - 60 CL	1.1	1.5	80	2.5 ÷ 4.0
JSWm 3CH - 60 CL	-	1.1	1.5	70	3.0 ÷ 4.5
PLURIJET series pumps					
-	PLURIJETm 5/90 - 60 CL	1.1	1.5	80	3.4 ÷ 4.6
-	PLURIJETm 6/90 - 60 CL	1.5	2	80	3.4 ÷ 4.6
-	PLURIJETm 4/100 - 60 CL	0.75	1	100	2 ÷ 3.5
-	PLURIJETm 3/130 - 60 CL	1.1	1.5	120	2.5 ÷ 4
-	PLURIJETm 4/130 - 60 CL	1.5	2	120	3.4 ÷ 4.6

⇒ (1) Pressure switch setting (recommended)

⇒ (2) Maximum flow rate at the minimum recommended pressure switch pressure

N.B. The pressure in the vessel should be pre-set to a value 0.2 bar lower than the recommended minimum setting of the pressure switch.

COMPONENTS 60 CL:

- Single phase pump
- 60 litre spherical tank
- Hose
- Pressure switch
- Pressure gauge
- Brass connector
- 1.5 metres power cable with Schuko plug

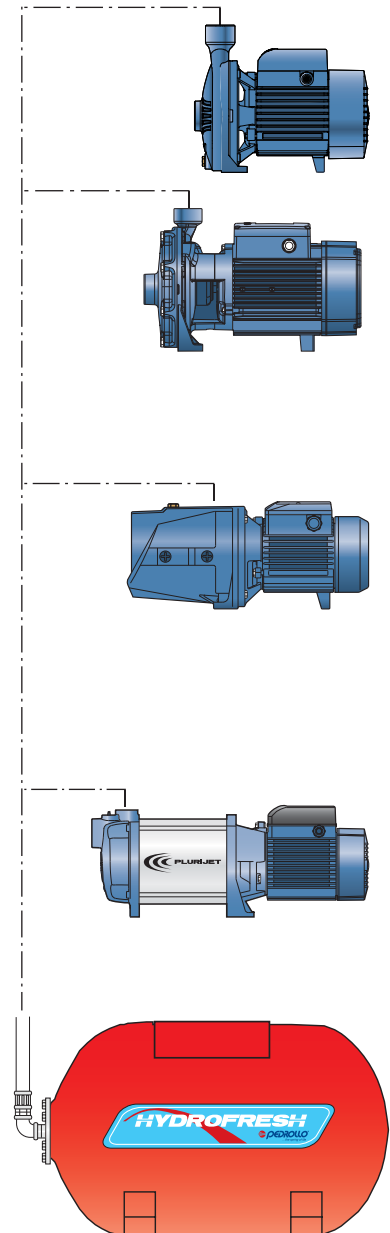

DIMENSIONS AND WEIGHT

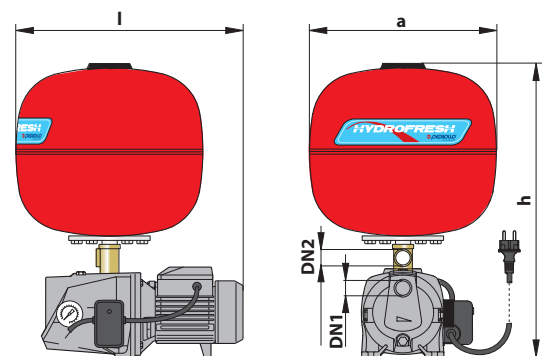

MODEL	PORTS	DIMENSION mm			WEIGHT kg
		DN1	DN2	l	
PKm 60 - 24 SF	1" 1"	383	360	568	12.6
PKm 65 - 24 SF	1" 1"	383	360	573	14.2
PKm 70 - 24 SF	1" 1"	410	360	586	17.4
CPm 158 - 24 SF	1" 1"	423	360	650	19.3
CPm 170 - 24 SF	1 1/4" 1"	496	360	670	25.7
2CPm 25/130N - 24 SF	1 1/4" 1"	437	360	631	21.8
JSWm 1C - 24 SF	1" 1"	437	360	551	16.5
JSWm 1B - 24 SF	1" 1"	437	360	551	17.3
JSWm 1A - 24 SF	1" 1"	437	360	551	17.6
JSWm 10H - 24 SF	1" 1"	463	360	572	21.0
JSWm 12H - 24 SF	1" 1"	463	360	572	22.0
JSWm 15H - 24 SF	1" 1"	463	360	572	22.4
JSWm 3CH - 24 SF	1 1/4" 1"	555	360	598	32.2

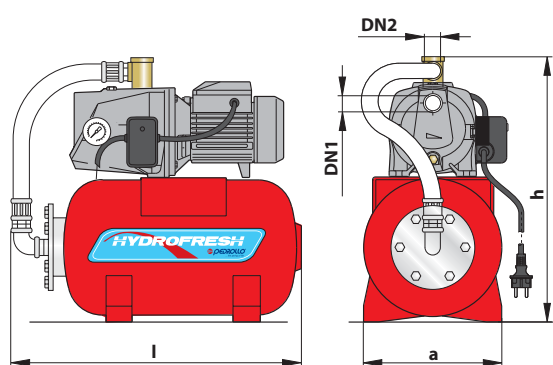

MODEL	PORTS	DIMENSION mm			WEIGHT kg
		DN1	DN2	l	
PKm 60 - 24 CL	1" 1"	540	255	503	13.2
PKm 65 - 24 CL	1" 1"	540	255	508	14.8
PKm 70 - 24 CL	1" 1"	540	255	521	18.0
CPm 158 - 24 CL	1" 1"	540	255	585	19.9
CPm 170 - 24 CL	1 1/4" 1"	540	255	605	26.3
3CPm 80E - 24 CL	1" 1"	540	255	537	17.7
4CPm 80E - 24 CL	1" 1"	540	255	537	18.9
3CPm 100E - 24 CL	1" 1"	540	255	537	18.3
4CPm 100E - 24 CL	1" 1"	540	255	537	21.6
JSWm 1C - 24 CL	1" 1"	540	265	486	17.1
JSWm 1B - 24 CL	1" 1"	540	265	486	17.9
JSWm 1A - 24 CL	1" 1"	540	265	486	18.2
JSWm 10H - 24 CL	1" 1"	540	315	507	21.6
JSWm 12H - 24 CL	1" 1"	540	315	507	22.6
JSWm 15H - 24 CL	1" 1"	540	315	507	23.0
JSWm 10M - 24 CL	1" 1"	540	315	507	21.6
JSWm 12M - 24 CL	1" 1"	540	315	507	22.6
JSWm 15M - 24 CL	1" 1"	540	315	507	23.0
JSWm 3CH - 24 CL	1 1/4" 1"	540	290	533	32.8
JCRm 1C - 24 CL	1" 1"	540	255	519	13.5
JCRm 1B - 24 CL	1" 1"	540	255	519	14.3
JCRm 1A - 24 CL	1" 1"	540	255	519	14.8
JCRm 10H - 24 CL	1 1/4" 1"	540	255	551	17.3
JCRm 15H - 24 CL	1 1/4" 1"	540	255	551	18.4
JCRm 10M - 24 CL	1 1/4" 1"	540	255	551	17.3
JCRm 15M - 24 CL	1 1/4" 1"	540	255	551	18.4

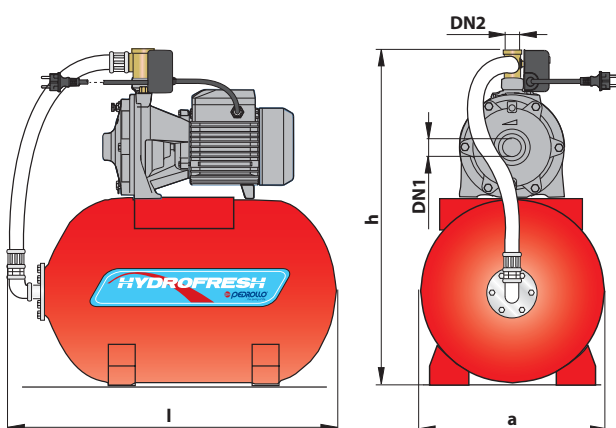

MODEL	PORTS	DIMENSION mm			WEIGHT kg
		DN1	DN2	l	
CPm 158 - 60 CL	1" 1"	750	380	725	26.5
CPm 170 - 60 CL	1 1/4" 1"	750	380	745	32.9
2CPm 25/130N - 60 CL	1 1/4" 1"	750	380	706	29.0
2CPm 25/140H - 60 CL	1 1/4" 1"	750	380	730	33.4
JSWm 10H - 60 CL	1" 1"	750	380	647	28.2
JSWm 12H - 60 CL	1" 1"	750	380	647	29.2
JSWm 15H - 60 CL	1" 1"	750	380	647	29.6
JSWm 10M - 60 CL	1" 1"	750	380	647	28.2
JSWm 12M - 60 CL	1" 1"	750	380	647	29.2
JSWm 15M - 60 CL	1" 1"	750	380	647	29.6
JSWm 3CH - 60 CL	1 1/4" 1"	750	380	673	39.4
PLURIJETm 5/90 - 60 CL	1 1/4" 1"	750	380	704	41.1
PLURIJETm 6/90 - 60 CL	1 1/4" 1"	750	380	704	43.2
PLURIJETm 4/100 - 60 CL	1" 1"	750	380	677	28.2
PLURIJETm 3/130 - 60 CL	1 1/4" 1"	750	380	704	39.3
PLURIJETm 4/130 - 60 CL	1 1/4" 1"	750	380	704	41.4

COMBIPRESS "CB2"

Pressure boosting sets



CB2 - 2CP



CB2 - PLURIJET



CB2 - F

OPERATING PRINCIPLES

COMBIPRESS are twin pump pressure boosting sets supplied pre-assembled and ready to install.

The sets are designed so that the pumps operate automatically in succession as the demand for water increases.

This results in significant energy savings as the second pump only runs at times of high demand.

The lead pump is alternated automatically by the control box.

USES

- Clean water and chemically non-aggressive liquids.
- Water supply: pressure boosting in industrial applications, condominiums, hotels, communities, water treatment plants, campsites, schools, hospitals, barracks, etc
- Irrigation: playing fields in general (football, golf, etc), agricultural cultivation, artificial snow systems.

CONSTRUCTION AND SAFETY STANDARDS

EN 60034-1
IEC 60034-1
CEI 2-3



CERTIFICATIONS



AM30



УкрТЕСТ-003

CONSTRUCTION CHARACTERISTICS

- **PUMPS** complete with suction and delivery manifolds, ball valves and non-return valves
- **BASE** made from sheet metal
- **PRE-INSTALLED** control systems, comprising a pressure gauge and two user-adjustable pressure switches (the factory settings are indicated in the following tables), fitted to the delivery manifold.
- **CONTROL BOX** complete with door-interlock power switch, low voltage pressure switch command circuit, automatic pump alternation function, thermal overload protection and pump start-up protection (prevents the pumps from continuously starting-up as a result of small and brief supply demands).

CB2m: single-phase 230 V - 50 Hz.

CB2: three-phase 230/400 V - 50 Hz up to 4 kW.

400/690 V - 50 Hz from 5.5 to 18.5 kW.

GUARANTEE

1 year subject to terms and conditions

PERFORMANCE DATA

50 Hz n= 2900 1/min HS= 0 m

MODEL	1~	3~	POWER		Q	H metres															
			kW	HP		m³/h	0	1.2	2.4	3.6	4.8	7.2	9.6	10.8	12.0	14.4	15.6	16.8	18.0	19.2	
					l/min	0	20	40	60	80	120	160	180	200	240	260	280	300	320		
CB2 - CP 150	●	●	2x0.75	2x1	H metres	29.5	29	29	28.5	28	26.5	24.5	23	21	15						
CB2 - CP 158	●	●	2x0.75	2x1		36	34	33.5	33	32.5	30	27	25								
CB2 - CP 170	●	●	2x1.1	2x1.5		41	-	-	38	37	35	32	30	27.5	22						
CB2 - CP 170M	●	●	2x1.1	2x1.5		36	-	-	35	34.5	33	31	30	29	26.5	25	23	21	19		
CB2 - CP 190	●	●	2x1.5	2x2		50	-	-	46	44.5	41.5	38	36	34.5	30.5	28	26				
CB2 - CP 200	●	●	2x2.2	2x3		58	-	-	55	54.5	52	49.5	48	46	42.5	40.5	38.5	36			

MODEL	1~	3~	POWER		Q	H metres						
			kW	HP		m³/h	0	6.0	12.0	24.0	36.0	48.0
					l/min	0	100	200	400	600	800	900
CB2 - CP 220C	●	●	2x2.2	2x3	H metres	32	31.5	31	30	28	24	21
CB2 - CP 220B	●	●	2x3	2x4		38	37.5	37	36	33.5	29	25
CB2 - CP 220A	●	●	2x4	2x5.5		49	48.5	48	46	43.5	39.5	36
CB2 - CP 220AH	●	●	2x5.5	2x7.5		52	51.5	51	49	47	44	42

MODEL	1~	3~	POWER		Q	H metres															
			kW	HP		m³/h	0	6.0	7.2	8.4	10.8	12.0	13.2	15.0	16.8	19.2	21.6	24.0	26.4	30.0	
					l/min	0	100	120	140	180	200	220	250	280	320	360	400	440	500		
CB2 - CP 25/160B	●	●	2x1.1	2x1.5	H metres	33	32.5	32	31.5	30.5	30	29	28	26.5	24	21.5	18				
CB2 - CP 25/160A	●	●	2x1.5	2x2		38	37	36.8	36.5	35.5	35	34	33	31.5	29.5	27	24	20			
CB2 - CP 25/160AR	●	●	2x2.2	2x3		42	41	41	40.5	39.5	39	38	37	36	34	31	28	24			
CB2 - CP 25/200B	●	●	2x2.2	2x3		49	48	47.5	47	45.5	45	44	43	41	38.5	36	32	28	22		
CB2 - CP 25/200A	●	●	2x3	2x4		57	56	55.8	55.5	54.5	53.5	53	52	50.5	48.5	46	43.5	40	33		

MODEL	1~	3~	POWER		Q	H metres																		
			kW	HP		m³/h	0	2.4	4.8	7.2	9.6	12.0	13.2	15.0	16.8	19.2	21.6	24.0	30.0	36.0	42.0	48.0	54.0	
					l/min	0	40	80	120	160	200	220	250	280	320	360	400	500	600	700	800	900		
CB2 - 2CP 25/130N	●	●	2x0.75	2x1	H metres	42	39	34	28.5	22	15													
CB2 - 2CP 25/140H	●	●	2x1.1	2x1.5		54	53	49	42	34	24													
CB2 - 2CP 160/160	●	●	2x1.5	2x2		66	64	60	53	44	35	30												
CB2 - 2CP 25/140M	●	●	2x1.1	1.5		47	46	44	42	38	34	31	27	22										
CB2 - 2CP 25/160B	●	●	2x1.5	2x2		58	56	54	52	48	44	41	37	33	26									
CB2 - 2CP 25/160A	●	●	2x2.2	2x3		68	66.5	65	62	58	54	51	47	42	35	28								
CB2 - 2CP 32/200C	●	●	2x3	2x4		70	-	66.5	65	63	60.5	59	57	55	52	49.5	46.5	36						
CB2 - 2CP 32/200B	●	●	2x4	2x5.5		85	-	81	79	77	75	74	72	69	66	62	58	49						
CB2 - 2CP 32/210B	●	●	2x5.5	2x7.5		94	-	94	93	91	89	87	85	83	79	75	70	56						
CB2 - 2CP 32/210A	●	●	2x7.5	2x10		112	-	111	110.5	110	108	107	105	102	99	94	89	74						
CB2 - 2CP 40/180C	●	●	2x4	2x5.5		64	-	-	-	-	62	61.3	60.1	59.0	57.5	56	54.5	49	43	35				
CB2 - 2CP 40/180B	●	●	2x5.5	2x7.5		76	-	-	-	-	73	72.5	71.8	71.0	70.0	69	67.5	64	59.5	54	46			
CB2 - 2CP 40/180A	●	●	2x7.5	2x10		88	-	-	-	-	85	84.5	83.8	83.0	82.0	81	79.5	76	72	67	60			
CB2 - 2CP 40/200B	●	●	2x9.2	2x12.5		97	-	-	-	-	94	93.5	92.8	92.0	91.0	90	88	85	80	74	68	61		
CB2 - 2CP 40/200A	●	●	2x11	2x15		105	-	-	-	-	102	101.5	100.8	100.0	99.0	98	97	93	88	83	76	69		

MODEL	1~	3~	POWER		Q	H metres															
			kW	HP		m³/h	0	0.6	1.2	2.4	3.6	4.8	7.2	8.4	9.6	10.8	12.0	13.2	14.4	15.6	
					l/min	0	10	20	40	60	80	120	140	160	180	200	220	240	260		
CB2 - 3CPm 80E	●	●	2x0.45	2x0.60	H metres	38	36	35	33.5	29	25	15.5	10	5							
CB2 - 4CPm 80E	●	●	2x0.60	2x0.85		50	48	47	43	38.5	33.5	22.5	16	10							
CB2 - 3CPm 100E	●	●	2x0.60	2x0.85		36	35.5	35	33.5	32	30	26	23	20	17	13.5	10	5			
CB2 - 4CPm 100E	●	●	2x0.75	2x1		46	45	44	42	40	38	33	30	26.5	22.5	19	15	10	5		
CB2 - 3CRm 80	●	●	2x0.45	2x0.60		38	36	35	32.5	29	25	15.5	10	5							
CB2 - 4CRm 80	●	●	2x0.60	2x0.85		50	48	47	43	38.5	33.5	22.5	16	10							
CB2 - 3CRm 100	●	●	2x0.60	2x0.85		36	35.5	35	33.5	32	30	25.5	23	20	17	13.5	10	5			

PERFORMANCE DATA

50 Hz n= 2900 1/min HS= 0 m

MODEL	1~	3~	POWER		Q	m ³ /h																	
			kW	HP		0	1.2	2.4	3.0	4.8	5.4	6.0	7.2	8.4	9.6	12.0	14.4	16.8	19.2				
						l/min	0	20	40	50	80	90	100	120	140	160	200	240	280	320			
CB2 - JSW 10H	●	●	2x0.75	2x1	H metres		56	47	41	39	32	30	28										
CB2 - JCR 10H	●	●	2x0.75	2x1			56	45	37	33	25	23.5	22										
CB2 - JCR 10M	●	●	2x0.75	2x1			46	41	37	35	28	26.5	25	22	21	19							
CB2 - JSW 15H	●	●	2x1.1	2x1.5			70	62	54	51	43	41	38										
CB2 - JSW 3CH	●	●	2x1.1	2x1.5			64	60	51	48	40	39	37	34	31								
CB2 - JSW 3BH	●	●	2x1.5	2x2			76	70	64	61	53	51	49	45	41	39							
CB2 - JSW 3AH	●	●	2x2.2	2x3			96	90	82	79	69	66	64	58	54	50							
CB2 - JSW 3CM	●	●	2x1.1	2x1.5			52	50	45	44	38	37	35	32	29	27	23	20					
CB2 - JSW 3BM	●	●	2x1.5	2x2			60	58	54	52	47	46	45	42	39	37	33	30					
CB2 - JSW 3AM		●	2x2.2	2x3			74	70	67	65	59	58	56	54	51	49	44	40					
CB2 - JSW 3CL	●	●	2x1.1	2x1.5			42	40	38	37	34	33	32	30	28	26	23	20	17	15			
CB2 - JSW 3BL	●	●	2x1.5	2x2			51	48	45	44	41	40	39	37	35	33	30	27	24	22			
CB2 - JSW 3AL		●	2x2.2	2x3			62	60	57	56	53	52	51	49	47	45	42	39	36.5	35			

MODEL	1~	3~	POWER		Q	m ³ /h																
			kW	HP		0	18.0	36.0	48.0	72.0	96.0	108.0	120.0	144.0	168.0	192.0	216.0	204.0	216.0			
						l/min	0	300	600	800	1200	1600	1800	2000	2400	2800	3200	3600	4000	4200		
CB2 - F 32/200C		●	2x4	2x5.5	H metres		46	43	38	34												
CB2 - F 32/200B		●	2x5.5	2x7.5			52	50.5	45	41												
CB2 - F 32/200A		●	2x7.5	2x10			60	56.5	53.5	50												
CB2 - F 40/200B		●	2x5.5	2x7.5			48	46.5	44.5	42	34											
CB2 - F 40/200A		●	2x7.5	2x10			56	55	54	52.5	46											
CB2 - F 50/200C		●	2x11	2x15			-	-	-	44	44	44	43	42	39	36	33					
CB2 - F 50/200B		●	2x15	2x20			-	-	-	52	52	52	51	50	47	44	40					
CB2 - F 50/200A		●	2x18.5	2x25			-	-	-	61	61	60.5	60	60	57	54	50	45				
CB2 - F 50/200AR		●	2x22	2x30			-	-	-	69	69	68.5	68	68	65	62	58	53				
CB2 - F 50/250D		●	2x9.2	2x12.5			-	-	51	49	44	37	32									
CB2 - F 50/250C		●	2x11	2x15			-	-	59	58	54	47	42									
CB2 - F 50/250B		●	2x15	2x20			-	-	72	71	69	65	62	59								
CB2 - F 50/250A		●	2x18.5	2x25			-	-	85	84	82	78	76	73								
CB2 - F 50/250AR		●	2x22	2x30			-	-	95	94	92	88	86	83								
CB2 - F 65/200B		●	2x15	2x20			-	-	-	45	45	45	45	45	44	42.5	41	38.5	35.5			
CB2 - F 65/200A		●	2x18.5	2x25			-	-	-	51	51	51	51	51	50	49	47	44.5	41.5	40		
CB2 - F 65/200AR		●	2x22	2x30			-	-	-	57	57	57	57	57	56	55	53	50.5	47.5	46		

MODEL	1~	3~	POWER		Q	m ³ /h																
			kW	HP		0	0.6	1.2	2.4	4.8	7.2	9.6	12.0	14.4	15.6	16.8	19.2	21.6	24.0			
						l/min	0	10	20	40	80	120	160	200	240	260	280	320	360	400		
CB2 - PLURIJET 4/80	●	●	2x0.60	2x0.85	H metres		50	48	47	43	33.5	22.5	10									
CB2 - PLURIJET 3/100	●	●	2x0.60	2x0.85			36	35.5	35	33.5	30	26	20	13.5	5							
CB2 - PLURIJET 4/100	●	●	2x0.75	2x1			46	45	44	42	38	33	26.5	19	10	5						
CB2 - PLURIJET 5/90	●	●	2x1.1	2x1.5			76	76	73.5	70	60.5	47	33									
CB2 - PLURIJET 6/90	●	●	2x1.5	2x2			93	93	90.5	86	74.5	59.5	43									
CB2 - PLURIJET 3/130	●	●	2x1.1	2x1.5			49	49	48.5	47.5	45	42.5	38.5	33.5	27	24						
CB2 - PLURIJET 4/130	●	●	2x1.5	2x2			65	65	64	63	60	56	50	43	35	31						
CB2 - PLURIJET 5/130	●	●	2x1.8	2x2.5			81	81	80.5	79	75	70	62.5	54	44	39						
CB2 - PLURIJET 6/130	●	●	2x2.2	2x3			97	97	96.5	94.5	90	83	74.5	64	52	46						
CB2 - PLURIJET 3/200	●	●	2x1.1	2x1.5			44	43.5	43.5	43	42	40.5	38	35	31	29	27.5	23	18	13		
CB2 - PLURIJET 4/200	●	●	2x1.5	2x2			58	57.5	57.5	57	55	52.5	49.5	45	40	38	35.5	30	24	17		
CB2 - PLURIJET 5/200	●	●	2x1.8	2x2.5			73	72	71.5	71	69	65.5	62	56.5	51	48	44.5	38	30	22		
CB2 - PLURIJET 6/200	●	●	2x2.2	2x3			87	86	85.5	85	82	78	73	67	60	57	53	45	36	26		

MODEL	1~	3~	POWER		Q	m ³ /h																
			kW	HP		0	1.2	2.4	3.6	4.8	6	7.2	8.4	9.6	10.8	12	13.2	14.4				
						l/min	0	20	40	60	80	100	120	140	160	180	200	220	240			
CB2 - VL 2/3	●	●	2x0.75	2x1	H metres		60	58	55	51	47	42	36	30	23							
CB2 - VL 2/4	●	●	2x1.1	2x1.5			84	80	75	70	65	59	51	42.5	34							
CB2 - VL 2/5	●	●	2x1.5	2x2			90	87	83	78	73	66	58	48	38							
CB2 - VL 4/2	●	●	2x0.75	2x1			50	-	48	46	44	41	38	35	32	28	24	19	14			
CB2 - VL 4/3	●	●	2x1.1	2x1.5			67	-	65	62.5	60	56.5	52	48	44	38	32	25	18			
CB2 - VL 4/4	●	●	2x1.5	2x2			75	-	72	69	66	64	60	57	53	48	43	38	32			
CB2 - VL 4/5	●	●	2x2.2	2x3		105	-	101	98	94	90	86	80	75	67	60	52	44				

DIMENSIONS AND WEIGHT

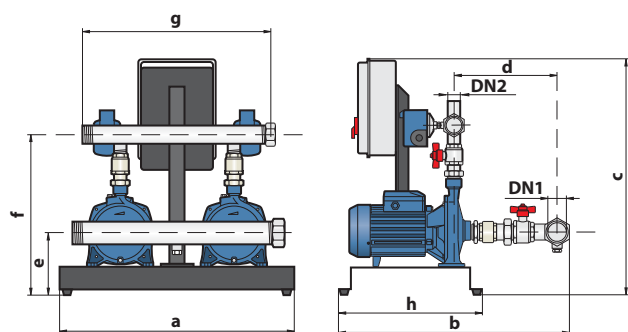

CB2 - CP

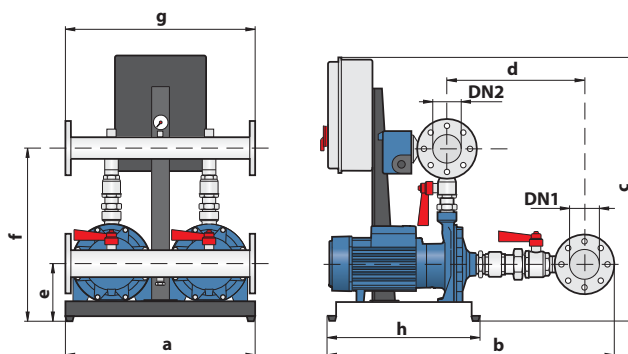

CB2 - 2CP

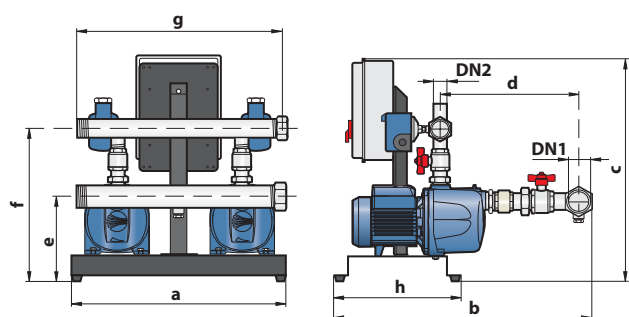

CB2 - 3÷4CP

MODEL		PORTS		DIMENSIONS mm									kg				
Single-phase	Three-phase	DN1	DN2	a	b	c	d	e	f	g	h	1~	3~				
CB2 - CPm 150	CB2 - CP 150	1½"	1½"	520	560	620	255	160	450	500	305	45.0	43.8				
CB2 - CPm 158	CB2 - CP 158											45.0	45.5				
CB2 - CPm 170	CB2 - CP 170	2	1½"	615	625	630	280	190	480		370	65.0	64.3				
CB2 - CPm 170M	CB2 - CP 170M						300		520			65.0	64.3				
CB2 - CPm 190	CB2 - CP 190	100	80	700	1000	780	430	220	650		700	560	-	80.0			
-	CB2 - CP 200												-	173.0			
-	CB2 - CP 220C									-			175.0				
-	CB2 - CP 220B									-			181.0				
-	CB2 - CP 220A									-			181.0				
-	CB2 - CP 220AH									-			-				
CB2 - CPm 25/160B	CB2 - CP 25/160B	2	1½"	615	645	630	320	280	480	370	305	70.0	69.0				
CB2 - CPm 25/160A	CB2 - CP 25/160A											70.0	69.0				
-	CB2 - CP 25/160AR											-	70.0				
-	CB2 - CP 25/200A-B											-	83.0				
CB2 - 2CPm 25/130N	CB2 - 2CP 25/130N	1½"	1½"	520	600	620	300	155	420	500	305	51.0	50.5				
CB2 - 2CPm 25/140H	CB2 - 2CP 25/140H						330		170			455	67.5	67.0			
CB2 - 2CPm 25/140M	CB2 - 2CP 25/140M						350		170			455	67.5	67.0			
CB2 - 2CPm 160/160	CB2 - 2CP 160/160	2	1½"	615	625	630	385	190	495	370	305	77.5	77.0				
CB2 - 2CPm 25/160B	CB2 - 2CP 25/160B											77.5	77.0				
-	CB2 - 2CP 25/160A	3	2	700	910	780	400	200	600	700	565	-	119.0				
-	CB2 - 2CP 32/200C											-	125.0				
-	CB2 - 2CP 32/200B											-	156.0				
-	CB2 - 2CP 32/210B											-	163.0				
-	CB2 - 2CP 32/210A											-	175.0				
-	CB2 - 2CP 40/180C											-	-				
-	CB2 - 2CP 40/180B	100	80	980	780	420	210	610	630	370	305	-	185.0				
-	CB2 - 2CP 40/180A											-	195.0				
-	CB2 - 2CP 40/200A-B											-	255.0				
-	-											-	-				
CB2 - 3CPm 80E	-	1½"	1½"	520	600	620	300	155	420	500	305	51.0	-				
CB2 - 3CPm100E	-				596							350	445	67.5	-		
CB2 - 4CPm 80E	-				595							630	330	170	455	67.5	-
CB2 - 4CPm100E	-				670							340	190	495	77.5	-	

DIMENSIONS AND WEIGHT

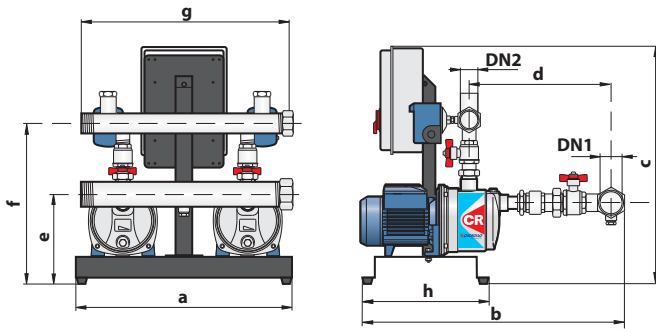

CB2 - 3÷4CR

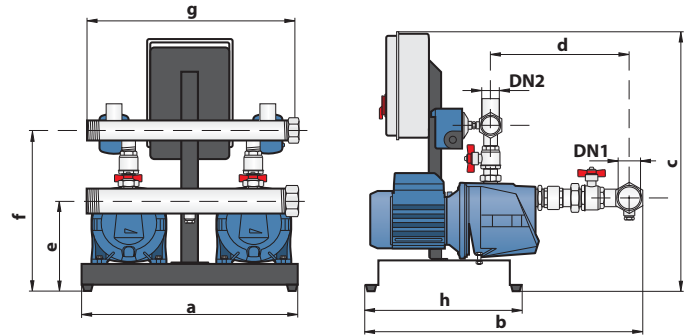

CB2 - JSW

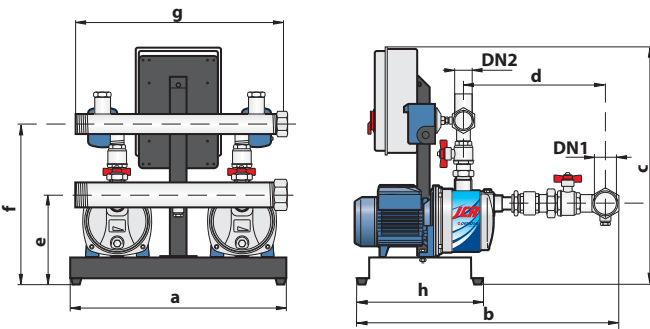

CB2 - JCR

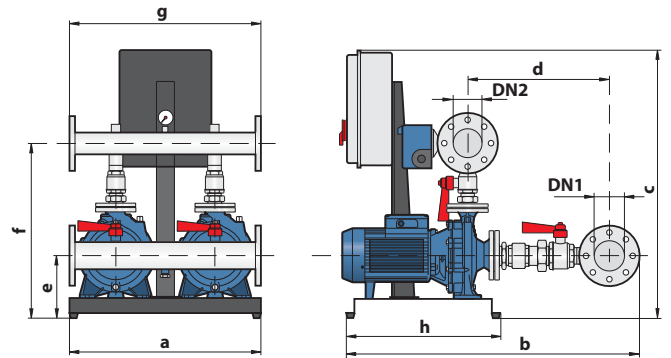

CB2 - F

MODEL		PORTS		DIMENSIONS mm								kg		
Single-phase	Three-phase	DN1	DN2	a	b	c	d	e	f	g	h	1~	3~	
CB2 - 3CRm 80	-	1½"	1½"	520	600	620	300	155	420	500	305	51.0	-	
CB2 - 3CRm 100	-				596		350	170	445			67.5	-	
CB2 - 4CRm 80	-				595		330	455	67.5			-		
CB2 - JSWm 10H-15H	CB2 - JSW 10H-15H				630		340	220	400			48.0	47.5	
CB2 - JCRm 10H-10M	CB2 - JCR 10H-10M	700	350	210	420	41.0	40.5							
CB2 - JSWm 3CH-CM-CL	CB2 - JSW 3CH-CM-CL	2"	1½"	710	780	895	440	230	660	700	565	78.5	76.5	
CB2 - JSWm 3BH-BM-BL	CB2 - JSW 3BH-BM-BL											710	400	230
-	CB2 - JSW 3AH-AM-AL	100	80	700	910	780	895	440	230	660	700	565	-	78.5
-	CB2 - F 32/200C												-	161.0
-	CB2 - F 32/200B												-	173.0
-	CB2 - F 32/200A												-	181.0
-	CB2 - F 40/200B	125	100	800	920	780	440	310	725	800	700	-	182.0	
-	CB2 - F 40/200A											-	189.0	
-	CB2 - F 50/200C											-	383.0	
-	CB2 - F 50/200B											-	415.0	
-	CB2 - F 50/200A-AR	125	100	800	1200	1330	450	330	770	800	700	-	440.0-464.0	
-	CB2 - F 50/250D											-	398.0	
-	CB2 - F 50/250C											-	408.0	
-	CB2 - F 50/250B											-	442.0	
-	CB2 - F 50/250A-AR	150	125	1300	520	320	800	780	800	780	780	-	468.0-488.0	
-	CB2 - F 65/200B											-	455.0	
-	CB2 - F 65/200A-AR											-	475.0-530.0	

DIMENSIONS AND WEIGHT

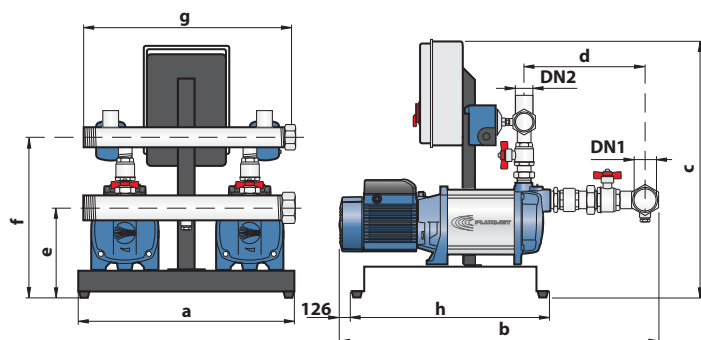

CB2 - PLURIJET

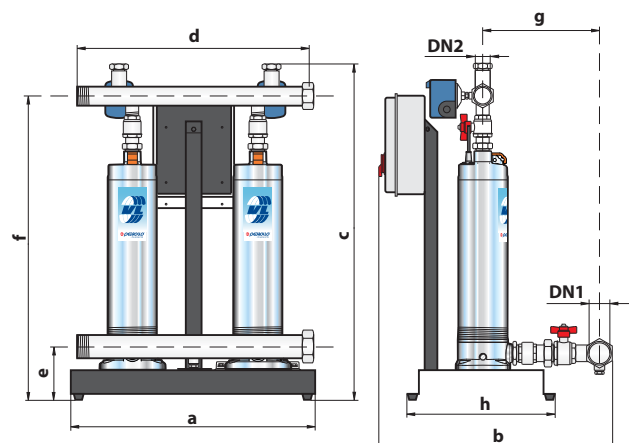

CB2 - VL

MODEL		PORTS		DIMENSIONS mm								kg		
Single-phase	Three-phase	DN1	DN2	a	b	c	d	e	f	g	h	1~	3~	
CB2 - PLURIJETm 3/100	-	1½"	1½"	520	596	630	350	170	445	500	305	67.5	-	
CB2 - PLURIJETm 4/80	-				595		330		455			67.5	-	
CB2 - PLURIJETm 4/100	-				670		340		495			77.5	-	
CB2 - PLURIJETm 5/90	CB2 - PLURIJET 5/90	2"	1½"	700	929	780	340	230	395	500	560	88.2	83.8	
CB2 - PLURIJETm 6/90	CB2 - PLURIJET 6/90				960							92.4	90.6	
CB2 - PLURIJETm 3/130	CB2 - PLURIJET 3/130				866							84.6	80.8	
CB2 - PLURIJETm 4/130	CB2 - PLURIJET 4/130				897							88.8	86.8	
-	CB2 - PLURIJET 5/130				929							-	90.8	
-	CB2 - PLURIJET 6/130				960							-	92.6	
CB2 - PLURIJETm 3/200	CB2 - PLURIJET 3/200				866							84.6	80.8	
CB2 - PLURIJETm 4/200	CB2 - PLURIJET 4/200				897							88.8	86.8	
-	CB2 - PLURIJET 5/200				-							-	90.8	
-	CB2 - PLURIJET 6/200				960							-	92.6	
CB2 - VLm 2/3 - 4/2 (1)	-	2"	2"	615	925	500	125	130	855	325	370	69.6	-	
-	CB2 - VL 2/3 - 4/2 (1)				675				895			825	-	67.4
CB2 - VLm 2/4 (1)	CB2 - VL 2/4 (1)				972				902			73.6	71.4	
CB2 - VLm 4/3 (1)	CB2 - VL 4/3 (1)				968				898			91.0	87.0	
CB2 - VLm 2/5 (1)	CB2 - VL 2/5 (1)				910				840			90.0	86.0	
CB2 - VLm 4/4 (1)	CB2 - VL 4/4 (1)				910				840			90.0	86.0	
CB2 - VLm 4/5 (1)	CB2 - VL 4/5 (1)				1030				973			108.0	100.0	

(1) Groups with stainless steel manifolds

Asynchronous single-phase electric motors



PERFORMANCE RANGE

- **0.37 ÷ 2.2 kW** (0.50 ÷ 3 HP) 2 pole
- **0.55 ÷ 1.5 kW** (0.75 ÷ 2 HP) 4 pole

APPLICATION LIMITS

- Rated voltage $\pm 5\%$
- Ambient temperature up to **+40 °C**
- Altitude up to **1000 metres** a.s.l.

CONSTRUCTION AND SAFETY STANDARDS

EN 60034-1
IEC 60034-1
CEI 2-3



CERTIFICATIONS



Italian Electrical Committee
(Authorisation n° 1064 date 27.3.87)

OPTIONALS AVAILABLE ON REQUEST

- Different voltages
- Motors for 60 Hz frequency

GUARANTEE

1 year subject to terms and conditions

CONSTRUCTION CHARACTERISTICS

- **MOTOR:** asynchronous closed type single-phase motors with external ventilation and permanently inserted capacitor, suitable for continuous duty.
 - A terminal box containing the capacitor and power cable connections is located on the upper face of the die-cast aluminium motor casing.
 - The stator pack is made from low loss coefficient, magnetic laminate.
 - The stator is made from machine wound, double insulated class H wire.
 - Resin impregnation is carried out using polyester resin in a continuous automated process, resulting in a high standard of insulation.
- **SINGLE-PHASE** 230 V - 50 Hz.
- **FRAME SIZE: B3**
- **INSULATION:** F class.
- **PROTECTION:** IP 44 in compliance with IEC 60034-5.
- **BALANCING:** in compliance with grade N of the standard IEC 60034-14
- **MOTOR CASING:** aluminium.
- **SHIELDS:** die-cast aluminium.
- **FAN:** glass fibre reinforced thermoplastic.
- **BEARINGS:** "ZZ" life-long lubrication protection.
- **ROTOR:** die-cast, dynamically balanced.
- **TERMINAL BOX:** with cable clamp.
- **CAPACITOR:** in compliance with VDE-IMQ standards.
- **PAINT:** the surface of the motor is protected as a result of a pickling, phosphating and passivation process and the application of two coats of oven cured electrostatic paint

TECHNICAL CHARACTERISTICS

MODEL	Rated power		Revs 1/min	Rated current A	Capacitor capacitance μF	Power factor $\cos \varphi$	Efficiency η	Static torque	Static current	J kgm ²	Weight kg
	kW	HP						Rated torque	Rated current		

2 POLE

Km1 - 63 B/2	0.37	0.50	2850	2.8	14	0.90	69%	0.70	3.2	0.00038	4.9
Km1 - 71 B/2	0.55	0.75	2800	4.2	20	0.86	66%	0.70	3.0	0.00053	8.0
Km1 - 71 C/2	0.75	1	2800	5.2	25	0.93	68%	0.71	3.2	0.00058	8.0
Km1 - 80 B/2	1.1	1.5	2800	7.5	35	0.90	72%	0.77	3.3	0.00120	11.6
Km1 - 80 C/2	1.5	2	2800	9.7	45	0.93	74%	0.70	3.5	0.00140	12.6
Km1 - 90 LB/2	2.2	3	2840	16.0	50	0.83	76%	0.70	3.6	0.00260	17.2

4 POLE

Km1 - 80 A/4	0.55	0.75	1400	4.5	20	0.93	62%	0.78	2.6	0.00220	9.8
Km1 - 80 B/4	0.75	1	1400	5.5	25	0.95	65%	0.73	2.7	0.00280	11.5
Km1 - 90 S/4	1.1	1.5	1420	7.8	31.5	0.98	67%	0.72	2.6	0.00370	14.0
Km1 - 90 LA/4	1.5	2	1420	10.8	40	0.95	70%	0.75	2.8	0.00490	17.0

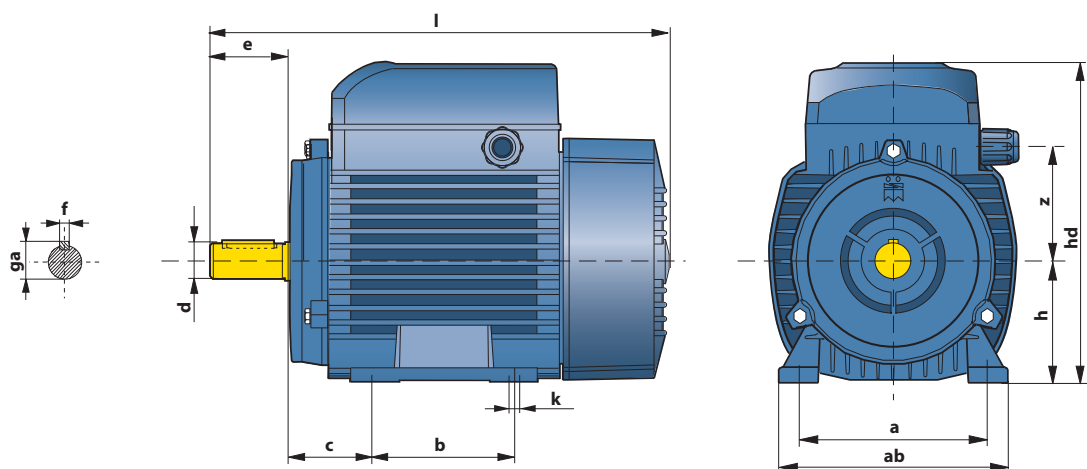

MODEL		DIMENSIONS mm												
2 Pole	4 Pole	a	ab	b	c	d	e	f	ga	h	hd	k	l	z
Km1-63 B/2	-	100	120	80	40	11	23	4	12.5	63	152	7	209	49.5
Km1-71 B/2	-	112	134	90	45	14	30	5	16	71	180	7	243	61
Km1-71 C/2	-	112	134	90	45	14	30	5	16	71	180	7	243	61
-	Km1-80 A/4	125	152	100	60	19	40	6	21.5	80	212	9	299	69
Km1-80 B/2	Km1-80 B/4	125	152	100	60	19	40	6	21.5	80	212	9	299	69
Km1-80 C/2	-	125	152	100	60	19	40	6	21.5	80	212	9	299	69
-	Km1-90 S/4	140	170	100	56	24	50	8	27	90	218.5	9	297	75
-	Km1-90 LA/4	140	170	125	56	24	50	8	27	90	218.5	9	322	75
Km1-90 LB/2	-	140	170	125	56	24	50	8	27	90	218.5	9	322	75

Circulators for heating and air-conditioning installations



PERFORMANCE RANGE

- Flow rate up to **5.2 m³/h**
- Head up to **7 m**

APPLICATION LIMITS

- Liquid temperature from **+5 °C**
(-10 °C per DHL 25-32/70) up to **+110 °C** (class TF 110)
- Ambient temperature up to **+55 °C**
(+35 °C for DHL 25/70 - 32/70)
- Maximum working pressure **10 bar** (PN 10)
- Maximum glycol percentage 50%
- The rotor shaft should be installed horizontally

CONSTRUCTION AND SAFETY STANDARDS

EN 60335-1
IEC 60335-1
CEI 61-150



POS. CONSTRUCTION CHARACTERISTICS

1	PUMP BODY	Cast iron	
2	IMPELLER	Technopolymer	
3	SHAFT	Stainless steel	
4	SWITCH	Three positions	
5	CAPACITOR	Pump	Capacitance
		<i>Single-phase</i>	<i>(230 V)</i>
		DHL 25/35	1.5 µF 400 VL
		DHL 25/55-65	2.0 µF 400 VL
	DHL 25-32/70	3.5 µF 400 VL	
6	MOTOR	Single-phase 230 V - 50Hz – Insulation: H class – Protection: IP 44	

CERTIFICATIONS



AN30



VspTECT-003

INSTALLATION AND USE

Suitable for use with clean water and liquids that are not chemically aggressive towards the materials from which the circulator is made.

Ideal for the forced-circulation of hot and cold water, the circulator has **three speed** settings.

The pump should be installed in an enclosed environment, or at least sheltered from inclement weather.

GUARANTEE

1 year subject to terms and conditions

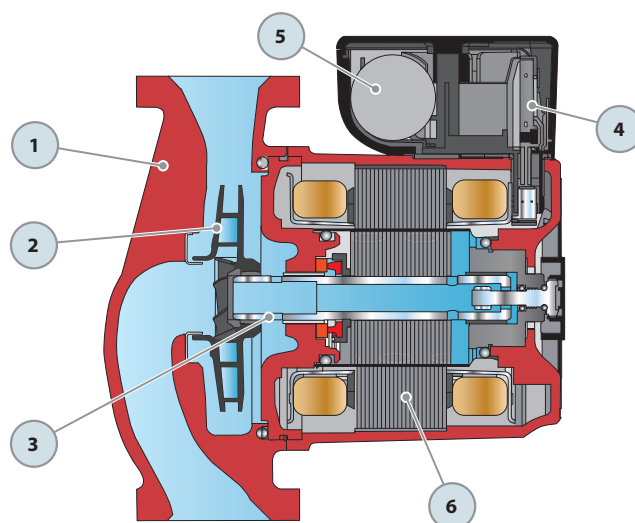

CHARACTERISTIC CURVES AND PERFORMANCE DATA

50 Hz n= 2900 1/min HS= 0 m

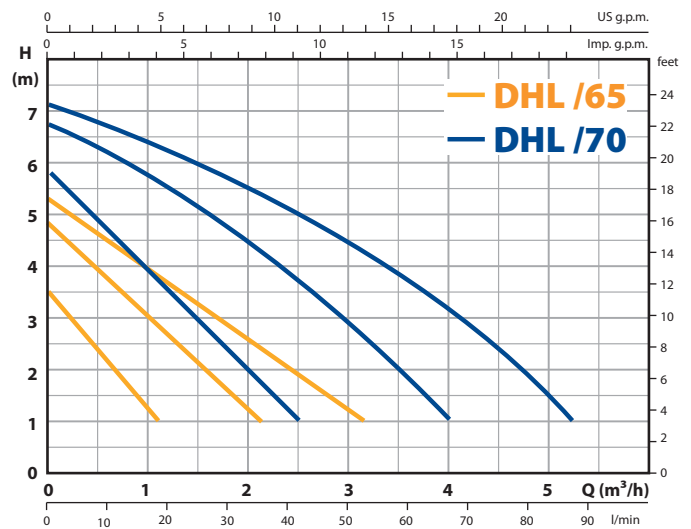
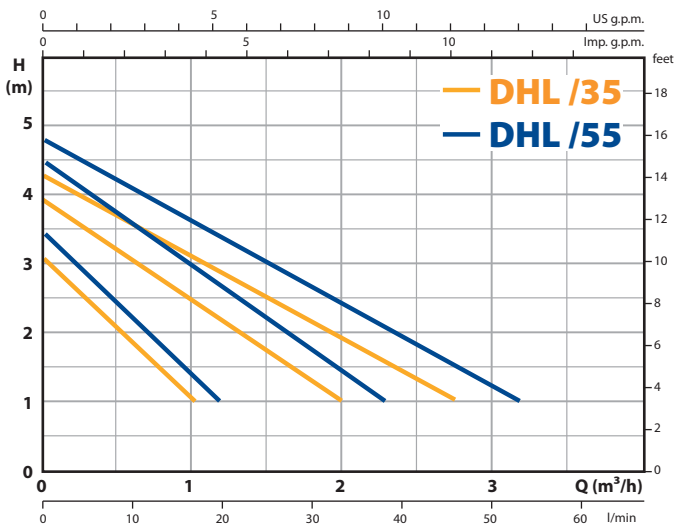

MODEL	DIMENSIONS	PERFORMANCE		Speed	rpm	P1 (W)	In (A)
		m³/h	metres				
Single-phase							
DHL 25/35-130	130	0.3 ÷ 2.8	4 ÷ 1	3	2300	48	0.21
DHL 25/35-180	180			2	1950	46	0.20
				1	1400	34	0.15
DHL 25/55-130	130	0.3 ÷ 3.2	4.5 ÷ 1	3	2350	52	0.23
DHL 25/55-180	180			2	1900	46	0.20
				1	1350	36	0.16
DHL 25/65-130	130	0.3 ÷ 3.2	5 ÷ 1	3	2200	62	0.27
DHL 25/65-180	180			2	1800	58	0.25
				1	1300	38	0.16
DHL 25/70-180	180	0.3 ÷ 5.2	7 ÷ 1	3	2650	125	0.55
DHL 32/70-180	180			2	2520	103	0.48
				1	2030	92	0.45

MODEL	PORTS		DIMENSIONS mm						Peso kg
	DN1	DN2	a1	a2	b1	b2	c1	c2	
Single-phase									
DHL 25/35-130								130	2.7
DHL 25/35-180								180	3.0
DHL 25/55-130	1½"	1½"	101.5	33.7	76.7	51.3	68.2	130	2.7
DHL 25/55-180								180	3.0
DHL 25/65-130								130	2.7
DHL 25/65-180								180	3.0
DHL 25/70-180	1½"	1½"	115.5	33.7	76.7	51.3	68.2	180	3.5
DHL 32/70-180	2"	2"						180	3.6

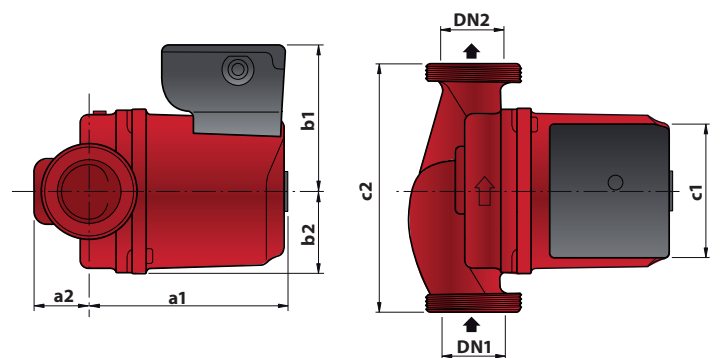

PALLETIZATION

MODEL	n° pumps	H (mm)	kg 1~
Single-phase			
DHL 25/35-130	200	880	557
DHL 25/35-180	180	890	557
DHL 25/55-130	200	880	557
DHL 25/55-180	180	890	557
DHL 25/65-130	200	880	557
DHL 25/65-180	180	890	557
DHL 25/70-180	180	890	647
DHL 32/70-180	180	890	665

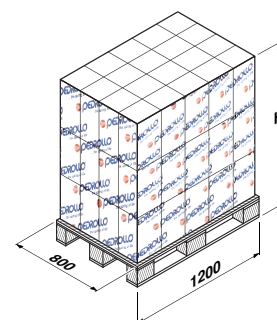

ACCESSORIES



SF - SPHERICAL TANK

MODEL	FITTING	CAPACITY
24 SF	1"	24 litres

- Maximum working pressure 8 bar
- Replaceable butyl rubber diaphragm

CL - CYLINDRICAL TANKS



MODEL	FITTING	CAPACITY
24 CL	1"	20 litres
60 CL	1"	60 litres
100 CL	1"	100 litres
200 CL	1½"	200 litres
300 CL	1½"	300 litres

- Maximum working pressure 10 bar
- Replaceable butyl rubber diaphragm

VT - VERTICAL TANKS



8-19 VT

MODEL	FITTING	CAPACITY
8 VT	1"	8 litres
19 VT	1"	19 litres
60 VT	1"	60 litres
100 VT	1"	100 litres
200 VT	1½"	200 litres
300 VT	1½"	300 litres
500 VT	1½"	500 litres

- Maximum working pressure 10 bar (8 bar for 8VT, 19VT)
- Replaceable butyl rubber diaphragm

SPHERICAL KIT



MODEL KS 24

- 24 litres spherical tank
- 0 ÷ 6 bar pressure gauge
- 5-way fitting - 1" gas
- Pressure switch "FSG 2"

CYLINDRICAL KIT



MODEL KC 24

- 20 litres cylindrical tank
- 0 ÷ 6 bar pressure gauge
- 5-way fitting - 1" gas
- hose 1" gas (500 mm)
- pressure switch "FSG 2"

MODEL KC 60

- 60 litres cylindrical tank
- 0 ÷ 6 bar pressure gauge
- 5-way fitting - 1" gas
- hose 1" gas (600 mm)
- pressure switch "FSG 2"



AIRFLO - AUTOMATIC AIR FEEDERS

MODEL	SUITABLE FOR TANKS
AIRFLO 1	100 ÷ 500 litres
AIRFLO 2	600 ÷ 1000 litres

- Automatic air feeders suitable for maintaining the air cushion in surge tanks without a diaphragm.

NA - 3-WAY NIPPLE FOR AIR FEEDERS

NA 1.00	1" x 1"	NA 1.50	1½" x 1½"
NA 1.25	1¼" x 1¼"	NA 2.00	2" x 2"

- 3-way brass fittings for connections with air feeders (AIRFLO)



PRESSURE SWITCHES

MODEL	MANUFACTURER	STANDARD SETTING (*)
FSG 2	SQUARE D	1.4 ÷ 2.8 bar
FYG 22	SQUARE D	5.4 ÷ 7.0 bar
FYG 32	SQUARE D	8 ÷ 10.5 bar
PM/5	ITALTECNICA	1.4 ÷ 2.8 bar
PT/5 SK (three-phase)	ITALTECNICA	1.4 ÷ 2.8 bar

(*) User adjustable

PRESSURE GAUGES



MC 6

MR 6-10

MODEL	FITTING	DIAMETER	SCALE
MC 6	¼" - central	50 mm	0 ÷ 6 bar
MR 6	¼" - radial	63 mm	0 ÷ 6 bar
MR 10	¼" - radial	63 mm	0 ÷ 10 bar

GLYCERIN FILLED PRESSURE GAUGES



MCG 6

MRG 6-10

MODEL	FITTING	DIAMETER	SCALE
MCG 6	¼" - central	50 mm	0 ÷ 6 bar
MRG 6	¼" - radial	63 mm	0 ÷ 6 bar
MRG 10	¼" - radial	63 mm	0 ÷ 10 bar



R 3



R 5

3 - 5 WAY FITTINGS

MODEL	FITTING
R 3 - 3 way	1"
R 5 - 5 way	1"

- R 3: three-way brass fittings with 1" gas connections
- R 5: five-way brass fittings with 1" gas and ¼" gas connections

HOSES



MODEL			PIPE	FITTINGS	LENGTH		
TF 5	TF 6	TF 10	1"	1" x 1"	500 mm	600 mm	1000 mm

- Flexible EPDM rubber hoses
- Maximum working pressure 10 bar

HOSES COMPLETE WITH ELBOW

MODEL		PIPE	FITTINGS	LENGTH	
TFG 5	TFG 6	3/4"	1" x 1"	500 mm	600 mm

- Flexible EPDM rubber hoses
- Maximum working pressure 10 bar

FLOAT SWITCHES



MODEL			CABLE (*)	LENGTH (*)		
0315/3	0315/5	0315/10	H07 RN-F or PVC	3 metres	5 metres	10 metres

- With **H07 RN-F** cable: single function (**emptying**) floats, with 10 A switch
- With **PVC** cable: dual function (**emptying and filling**) floats, with 10 A switch

MODEL			CABLE (*)	LENGTH (*)		
T 80/3	T 80/5	T 80/10	H07 RN-F or PVC	3 metres	5 metres	10 metres

- With **H07 RN-F** cable: - single function (**emptying**) floats, with double watertight protection chamber and 10 A switch
- With **PVC** cable: - dual function (**emptying and filling**) floats - double watertight protection chamber and 10 A switch

MODEL		CABLE*	LENGTH (*)	
SMALL 3	SMALL 5	H07 RN-F or PVC	3 metres	5 metres

- With H07 RN-F cable: -single function (emptying) floats, with double watertight protection chamber and 10 A switch
- With PVC cable: - dual function (emptying and filling) floats - double watertight protection chamber and 10 A switch

(*) → When ordering, please specify cable length (3, 5 or 10 metres) and type (H07 RN-F or PVC)

MODEL	CABLE	LENGTH
MAC 5	PVC	10 metres

- Tilting float: - dual function (emptying and filling) - double watertight protection chamber with 20 A switch

⇒ **Recommended for use with waste water collection stations (SAR)**

VF - FOOT VALVES



MODEL	FITTING
VF 0.5	1/2"
VF 0.75	3/4"
VF 1	1"
VF 1.25	1 1/4"
VF 1.5	1 1/2"
VF 2	2"

- Brass foot valves, stainless steel suction filter

VR - CHECK VALVES



MODEL	FITTINGS
VR 0.5	1/2"
VR 0.75	3/4"
VR 1	1"
VR 1.25	1 1/4"
VR 1.5	1 1/2"
VR 2	2"

- Brass check valves

VR-FT - BALL CHECK VALVES



MODEL	FITTINGS
VR-FT 1.25 - THREADED	1 1/4"
VR-FT 1.5 - THREADED	1 1/2"
VR-FT 2 - THREADED	2"

- Check valves for submersible pumps (sewage and waste water)
- Max. working pressure 10 bar
- Min. working pressure 0.3 bar
- Working temperature -10°C ÷ +80 °C

VR-FF - BALL CHECK VALVES



MODEL	FITTINGS
VR-FF/DN 65 - FLANGED	Ø 65 mm
VR-FF/DN 80 - FLANGED	Ø 80 mm

- Check valves for submersible pumps (sewage and waste water)
- Max. working pressure 10 bar
- Min. working pressure 0.3 bar
- Working temperature -10°C ÷ +80 °C

F - FILTER HOLDERS WITH PLASTIC HEAD



MODEL	THREADED FITTINGS	CARTRIDGE HEIGHT
MEDIUM - F 0.75	3/4"	5"
MEDIUM - F 1	1"	5"
JUNIOR - F 0.75	3/4"	7"
JUNIOR - F 1	1"	7"
SENIOR - F 0.75	3/4"	10"
SENIOR - F 1	1"	10"

- Maximum working pressure 5 bar (at temp. +20°C)
- Maximum temperature + 45°C (at pressure 2 bar)

RL - POLYESTER FILTER CARTRIDGES



MODEL	FILTRATION	CARTRIDGE HEIGHT	FILTER HOLDER
RL 5	50 µ	5"	MEDIUM F
RL 7	50 µ	7"	JUNIOR F
RL 10	50 µ	10"	SENIOR F

FA - POLYPROPYLENE FILTER CARTRIDGES



MODEL	FILTRATION	CARTRIDGE HEIGHT	FILTER HOLDER
FA 5	50 µ	5"	MEDIUM F
FA 7	50 µ	7"	JUNIOR F
FA 10	50 µ	10"	SENIOR F

HA - FILTER CARTRIDGE WITH POLYPHOSPHATE CRYSTALS



MODEL	CARTRIDGE HEIGHT	FILTER HOLDER
HA 10	10"	SENIOR F

LA - FILTER CARTRIDGE WITH ACTIVATED CARBON



MODEL	CARTRIDGE HEIGHT	FILTER HOLDER
LA 10 BX	10"	SENIOR F

WRENCH FOR FILTER HOLDERS



MODEL	FILTER HOLDER
WRENCH F	F

FLAT PVC HOSE



MODEL	FITTING	Ø INTERNAL	LENGTHS
TP 1.25	1¼"	32 mm	5 - 10 - 20 metres
TP 1.50	1½"	40 mm	5 - 10 - 20 metres
TP 2.00	2"	52 mm	5 - 10 - 20 metres
TP 2.50	2½"	63 mm	5 - 10 - 20 metres
TP 3.00	3"	76 mm	5 - 10 - 20 metres

- Flat, abrasion and weather resistant plasticized delivery hoses, complete with hosedail.
- ⇒ **Ideal for irrigation even with fertilisers and for draining water in combination with DRAINAGE PUMPS**

GARDEN KIT - SUCTION HOSE



MODEL	FITTING	LENGTH
GARDEN KIT	1"	7 metres

- Hose complete with foot valve
- ⇒ **Recommended for use with portable garden pumps such "BETTY"**

MT 1 - MECHANICAL FLOW METRE



MODEL	MAXIMUM FLOW RATE	MAXIMUM PRESSURE	FITTINGS
MT 1	120 l/min	3.5 bar	1" x 1"

- Mechanical flow metre for private use, suitable for measuring diesel fuel
- ⇒ **Recommended for use with "CK" series pumps**

NZ - DISPENSING NOZZLE WITH HOSE



MODEL	ELBOW FITTING
NZ 0.75	¾"
NZ 1.00	1"

- Aluminium dispensing nozzle complete with 4 metres long hose, reinforced with steel spiral, with threaded fittings
- ⇒ **Recommended for use with "CK" series pumps**

STRAIGHT HOSETAIL FITTINGS



MODEL	HOSETAIL	THREADED FITTING
RP 0.75	Ø 25 mm	¾"
RP 1	Ø 30 mm	1"
RP 1.25	Ø 35 mm	1¼"
RP 1.5	Ø 40 mm	1½"
RP 2	Ø 50 mm	2"

- Nylon fittings

CURVED HOSETAIL FITTINGS



MODEL	HOSETAIL	THREADED FITTING
RPG 0.75	Ø 25 mm	¾"
RPG 1	Ø 30 mm	1"
RPG 1.25	Ø 35 mm	1¼"
RPG 1.5	Ø 40 mm	1½"
RPG 2	Ø 50 mm	2"

- Nylon fittings

TEFLON TAPE FOR HYDRAULIC JOINTS



MODEL	LENGTH
TFN 1	12 m
TFN 2	50 m
TFN 3 ¾"	12 m

AEROSOL PAINT



MODEL	COLOUR	CAPACITY
SPRAY 1	Pedrollo blue	400 ml

CAPACITORS



type F= faston

MODEL	CAPACITANCE	Voltage	Frequency
06 F	6.3 μ F	450 V	50 ÷ 60 Hz
10 F	10 μ F	450 V	50 ÷ 60 Hz
10 FC (*)	10 μ F	450 V	50 ÷ 60 Hz
12 F	12.5 μ F	450 V	50 ÷ 60 Hz
14 F	14 μ F	450 V	50 ÷ 60 Hz
16 F - 500	16 μ F	500 V	50 ÷ 60 Hz
16 F - 450		450 V	50 ÷ 60 Hz
16 F - 250		250 V	50 ÷ 60 Hz
20 F - 500	20 μ F	500 V	50 ÷ 60 Hz
20 F - 450		450 V	50 ÷ 60 Hz
25 F - 450	25 μ F	450 V	50 ÷ 60 Hz
25 F - 250		250 V	50 ÷ 60 Hz
30 F	30 μ F	250 V	50 ÷ 60 Hz
31 F	31.5 μ F	450 V	50 ÷ 60 Hz
35 F	35 μ F	450 V	50 ÷ 60 Hz
40 F	40 μ F	450 V	50 ÷ 60 Hz
45 F	45 μ F	450 V	50 ÷ 60 Hz
50 F	50 μ F	450 V	50 ÷ 60 Hz
55 F	55 μ F	450 V	50 ÷ 60 Hz
60 F - 450	60 μ F	450 V	50 ÷ 60 Hz
60 F - 300		300 V	50 ÷ 60 Hz
60 F - 250		250 V	50 ÷ 60 Hz
70 F	70 μ F	450 V	50 ÷ 60 Hz
80 F	80 μ F	250 V	50 ÷ 60 Hz

- Capacitors with CE marking and VDE-IMQ approval (*) FC = Short faston connections

CAPACITORS



type C= with cable

MODEL	CAPACITANCE	Voltage	Frequency
10 C	10 μ F	450 V	50 ÷ 60 Hz
12 C	12.5 μ F	450 V	50 ÷ 60 Hz
16 C	16 μ F	450 V	50 ÷ 60 Hz
20 C - 500	20 μ F	500 V	50 ÷ 60 Hz
20 C - 450		450 V	50 ÷ 60 Hz
25 C - 500	25 μ F	500 V	50 ÷ 60 Hz
25 C - 450		450 V	50 ÷ 60 Hz
30 C - 450	30 μ F	450 V	50 ÷ 60 Hz
30 C - 250		250 V	50 ÷ 60 Hz
31 C - 500	31.5 μ F	500 V	50 ÷ 60 Hz
31 C - 450		450 V	50 ÷ 60 Hz
35 C - 500	35 μ F	500 V	50 ÷ 60 Hz
35 C - 450		450 V	50 ÷ 60 Hz
40 C	40 μ F	450 V	50 ÷ 60 Hz
50 C	50 μ F	450 V	50 ÷ 60 Hz
60 C	60 μ F	250 V	50 ÷ 60 Hz
70 C	70 μ F	250 V	50 ÷ 60 Hz
75 C	75 μ F	450 V	50 ÷ 60 Hz
80 C	80 μ F	250 V	50 ÷ 60 Hz

- Capacitors with CE marking and VDE-IMQ approval

ACCESSORIES



ELECTRICAL CABLE FOR LEVEL PROBES

MODEL	SECTION	WEIGHT PER METRE
CSL	1.5 mm ²	0,019 kg



POWER CABLE FOR SUBMERSIBLE PUMPS

MODEL	MODEL	WEIGHT PER METRE
4 x 1 mm ²	H07 RN-F	0,165 kg
4 x 1.5 mm ²	H07 RN-F	0,205 kg
4 x 2.5 mm ²	H07 RN-F	0,290 kg
4 x 4 mm ²	H07 RN-F	0,420 kg
4 x 6 mm ²	H07 RN-F	0,505 kg
4 x 10 mm ²	H07 RN-F	1,030 kg
4 x 16 mm ²	H07 RN-F	2,050 kg



(RECOMMENDED)

"3M" ELECTRICAL CABLE RESIN JOINT KIT

MODEL	No. OF CORES	CABLE SECTION	EXTERNAL JUNCTION DIAMETRE
RPS 1	4	1 ÷ 2.5 mm ²	Ø 32 mm
RPS 2	4	1 ÷ 10 mm ²	Ø 42 mm
RPS 3	4	4 ÷ 16 mm ²	Ø 48 mm



(ECONOMICAL)

"3M" ELECTRICAL CABLE HEAT-SHRINK JOINT KIT

MODEL	No. OF CORES	CABLE SECTION
GPS 1	4	1 ÷ 2.5 mm ²
GPS 2	4	4 ÷ 6 mm ²
GPS 3	4	10 mm ²
GPS 4	4	16 mm ²
GPS 5	4	25 mm ²
GPS 6	4	35 mm ²



POWER CABLE WITH PLUG

MODEL	CABLE SECTION	LENGTH	PLUG
H05 VV-F (PVC)	3 x 0.75 mm ²	150 cm	SCHUKO
H07 RN-F (NEOPRENE)	3 x 1 mm ²	150 cm	SCHUKO

BEARINGS



MODEL	DIMENSIONS
6201 ZZ	12 x 32 x 10 mm
6201 ZZ - C3	12 x 32 x 10 mm
6202 ZZ - C3	15 x 35 x 11 mm
6203	17 x 40 x 12 mm
6203 ZZ	17 x 40 x 12 mm
6203 ZZ - C3	17 x 40 x 12 mm
6203 2RS	17 x 40 x 12 mm
6204 ZZ	20 x 47 x 14 mm
6204 ZZ - C3	20 x 47 x 14 mm
6205 ZZ	25 x 52 x 15 mm
6206 ZZ - C3	30 x 62 x 16 mm
6212 ZZ - C3	60 x 110 x 22 mm
6303 ZZ - C3	17 x 47 x 14 mm
6303 2RS - C3	17 x 47 x 14 mm
6304 ZZ	20 x 52 x 15 mm
6304 ZZ - C3	20 x 52 x 15 mm
6304 2RS - C3	20 x 52 x 15 mm
6306 ZZ - C3	30 x 72 x 19 mm
6307 ZZ - C3	35 x 80 x 21 mm
6308 ZZ - C3	40 x 90 x 23 mm
6310 ZZ - C3	50 x 110 x 27 mm
6312 ZZ - C3	60 x 130 x 31 mm
6314 ZZ - C3	70 x 150 x 35 mm
3203 B - C3	17 x 40 x 17,5 mm
7203 B	17 x 40 x 12 mm
7303 B	17 x 47 x 14 mm

FANS

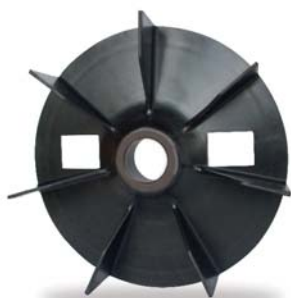

MODEL	DIMENSIONS	SHAFT DIAMETER
14VN05	85 x 18 mm	12 mm
14VN06	104 x 21 mm	12 mm
14VN07	125 x 24 mm	14.5 mm
14VN075	118 x 22 mm	14.5 mm
14VN08	138 x 27 mm	20 mm
14VN081	132 x 27 mm	20 mm
14VN0815	132 x 27 mm	20 mm
14VN09	162 x 32 mm	24 mm
14VN10	176 x 38 mm	28 mm
14VN10162	155 x 37 mm	28 mm
14VN132	165 x 45 mm	36 mm

CONTROL BOXES

QEM - CONTROL BOXES FOR 4" SINGLE-PHASE BOREHOLE PUMPS



MODEL	MOTOR POWER		CAPACITOR	RATED CURRENT
	kW	HP	CAPACITANCE	A
Single-phase				
QEM 050	0.37	0.50	16 μ F	5
QEM 075	0.55	0.75	20 μ F	6
QEM 100	0.75	1	30 μ F	7
QEM 150	1.1	1.5	40 μ F	10
QEM 200	1.5	2	50 μ F	13
QEM 300	2.2	3	75 μ F	18

- Single-phase 230 V 50 Hz

QET - CONTROL BOXES FOR 4" AND 6" THREE-PHASE BOREHOLE PUMPS



MODEL	MOTOR POWER		RATED CURRENT
	kW	HP	A
Three-phase			
QET 050	0.37	0.50	1.7
QET 075	0.55	0.75	2
QET 100	0.75	1	2.5
QET 150	1.1	1.5	3.9
QET 200	1.5	2	4.8
QET 300	2.2	3	7
QET 400	3	4	9
QET 550	4	5.5	11.5
QET 750	5.5	7.5	15.5
QET 1000	7.5	10	21.5
QET 1250	9.2	12.5	23.5
QET 1500	11	15	27.5
QET 2000	15	20	36
QET 2500	18.5	25	45
QET 3000	22	30	54
QET 4000	30	40	68

- The control box has a selector for manual or automatic operation (with float switch, pressure switch, etc.).
- Three-phase 400 V 50 Hz

QSM - CONTROL BOXES FOR 4" SINGLE-PHASE PUMPS WITH LEVEL PROBES



Level probes

MODEL	MOTOR POWER		CAPACITOR	RATED CURRENT
	kW	HP	CAPACITANCE	A
Single-phase				
QSM 050	0.37	0.50	16 μ F	5
QSM 075	0.55	0.75	20 μ F	6
QSM 100	0.75	1	30 μ F	7
QSM 150	1.1	1.5	40 μ F	10
QSM 200	1.5	2	50 μ F	13
QSM 300	2.2	3	75 μ F	17.5

- The control box has a selector for manual or automatic operation (with float switch, pressure switch, etc.) and may be connected to level probes that protect the pump against dry running.
- **Single-phase 230 V 50 Hz**

QST - CONTROL BOXES FOR 4" AND 6" THREE-PHASE PUMPS WITH LEVEL PROBES



Level probes

MODEL	MOTOR POWER		RATED CURRENT
	kW	HP	A
Three-phase			
QST 50	0.37	0.50	1.7
QST 75	0.55	0.75	2
QST 100	0.75	1	2.5
QST 150	1.1	1.5	3.9
QST 200	1.5	2	4.8
QST 300	2.2	3	7
QST 400	3	4	9
QST 550	4	5.5	11.5
QST 750	5.5	7.5	15.5
QST 1000	7.5	10	21.5
QST 1250	9.2	12.5	23.5
QST 1500	11	15	27.5
QST 2000	15	20	36
QST 2500	18.5	25	45
QST 3000	22	30	54
QST 4000	30	40	68

- The control box has a selector for manual or automatic operation (with float switch, pressure switch, etc.) and may be connected to level probes that protect the pump against dry running.
- **Three-phase 400 V 50 Hz**

CONTROL BOXES

EVOLUTION - CONTROL BOXES FOR 4" AND 6" BOREHOLE PUMPS



MODEL	ADJUSTABLE POWER		VOLTAGE	RATED CURRENT A
	kW	HP		
EVOLUTION-MONO	from 0.37 to 2.2	from 0.5 to 3	Single-phase 230 V 50 Hz	from 2 to 16
EVOLUTION-TRI/1	from 0.55 to 7.5	from 0.75 to 10	Three-phase 400 V 50 Hz	from 2 to 15
EVOLUTION-TRI/2	from 7.5 to 10	from 10 to 15	Three-phase 400 V 50 Hz	from 16 to 24

- The control box contains a circuit board that makes it possible to adjust the limit at which the overload and short-circuit protection intervenes; the circuit board also protects the pump against dry running by controlling the cos ϕ value without additional level probes.
- The control box may be connected to a float switch (or a pressure switch, etc.).

QES - CONTROL BOXES FOR SINGLE PHASE DRAINAGE PUMPS



MODEL	MOTOR POWER		CAPACITOR	RATED CURRENT A
	kW	HP	CAPACITANCE	
Single-phase QES 300 MONO	2.2	3	60 μ F	16
QES 300 MONO-AL (*)	2.2	3	60 μ F	16

► The control box is designed for connection to the thermal protector built into the motor windings of the VXcm30, PVXcm30, MCM30, PMCM30 drainage pumps.

(*) QES 300 MONO-AL, control box with:

- Contacts for connection to an auxiliary float switch for level alarm
- Red warning light that signals conditions exceeding the alarm level
- Input connections (220÷230V / 50Hz) for the external alarm (light, siren, etc.)

- Single-phase 230 V 50 Hz

QES - CONTROL BOXES FOR THREE PHASE DRAINAGE PUMPS



MODEL	ADJUSTABLE POWER		RATED CURRENT A
	kW	HP	
Three-phase QES 150	1.1	1.5	4.2
QES 200	1.5	2	5.2
QES 300	2.2	3	6.5

► The control box comes complete with a selector for manual or automatic operation (with float switch) and is designed for connection to the thermal protector built into the motor windings of the VXC, PVXC, MC, PMC drainage pumps.

- Three-phase 380 ÷ 415V 50 Hz

QED1 - ELECTRONIC CONTROL BOX FOR 1 DRAINAGE PUMP



MODEL	ADJUSTABLE POWER		VOLTAGE	RATED CURRENT A
	kW	HP		
QED1-MONO	from 0.37 to 2.2	from 0.5 to 3	single-phase 230 V 50 Hz	from 2 to 16
QED1-TRI	from 0.55 to 3.7	from 0.75 to 5	Three-phase 400 V 50 Hz	from 2 to 8

⇒ The control box is designed for connection to the thermal protector built into the motor windings of the VXC, PVXC, MC and PMC drainage pumps.

- The control box is designed to be connected to **three float switches** (start-up, shut-off and alarm level).
- The control box contains an electronic card that makes it possible to regulate the threshold at which the protection intervenes against overload currents and short-circuits.

QED2 - ELECTRONIC CONTROL BOX FOR 2 DRAINAGE PUMPS



MODEL	ADJUSTABLE POWER		VOLTAGE	RATED CURRENT A
	kW	HP		
QED2-MONO	from 0.37 to 2.2	from 0.5 to 3	single-phase 230 V 50 Hz	from 2 to 16
QED2-TRI	from 0.55 to 3.7	from 0.75 to 5	Three-phase 400 V 50 Hz	from 2 to 8

⇒ The control box is designed for connection to the thermal protector built into the motor windings of the VXC, PVXC, MC and PMC drainage pumps.

- The control box is designed to be connected to **four float switches** (alternate start-up of the first pump, alternate start-up of the second pump, shut-off and alarm level)
- The control box contains an electronic card that makes it possible to regulate the threshold at which the protection intervenes against overload currents and short-circuits.

CABLE SIZES FOR SUBMERSIBLE MOTORS

SINGLE-PHASE 230 V - 50 Hz

MOTOR POWER		cable section in mm ²						
kW	HP	4 x 1	4 x 1.5	4 x 2.5	4 x 4	4 x 6	4 x 10	4 x 16
		maximum cable length in metres						
0.37	0.50	60	90	140				
0.55	0.75	45	70	110	180			
0.75	1	35	50	85	140	210		
1.1	1.5	25	35	60	95	145	240	
1.5	2		30	45	75	115	190	305
2.2	3			30	50	75	125	200

THREE-PHASE 230 V - 50 Hz

MOTOR POWER		cable section in mm ²										
kW	HP	4x1	4 x 1.5	4 x 2.5	4 x 4	4 x 6	4 x 10	4 x 16	4 x 25	4 x 35	4 x 50	4 x 70
		maximum cable length in metres										
0.37	0.50	100	152	255								
0.55	0.75	83	126	210	338							
0.75	1	65	99	165	265	405						
1.1	1.5	48	72	120	192	292	485					
1.5	2		53	88	142	215	360					
2.2	3			60	97	147	245	392				
3	4			47	73	110	183	295	510			
4	5.5				55	83	138	220	380			
5.5	7.5					60	100	160	275	385		
7.5	10					45	73	114	195	275	395	
9.2	12.5						64	100	157	220	315	
11	15						54	87	135	190	270	378
13	17.5							75	117	164	236	330
15	20							65	102	144	205	287
18.5	25								82	114	162	225
22	30								69	95	137	190
30	40									70	102	142

THREE-PHASE 400 V - 50 Hz

MOTOR POWER		cable section in mm ²										
kW	HP	4x1	4 x 1.5	4 x 2.5	4 x 4	4 x 6	4 x 10	4 x 16	4 x 25	4 x 35	4 x 50	4 x 70
		maximum cable length in metres										
0.37	0.50	300										
0.55	0.75	250	380									
0.75	1	195	295									
1.1	1.5	145	215	360								
1.5	2	105	160	265	425							
2.2	3	70	110	180	290	440						
3	4	55	85	140	220	330						
4	5.5	40	60	105	165	250	415					
5.5	7.5		45	75	120	180	300	480				
7.5	10		35	55	95	135	220	340	585			
9.2	12.5			47	75	115	190	300	470			
11	15			40	65	95	160	260	405			
13	17.5				60	85	140	225	350	490		
15	20				50	75	125	195	305	430		
18.5	25					58	100	155	245	340	485	
22	30					49	85	130	205	285	410	570
30	40					36	63	96	152	210	305	425

Voltage drop 3% - Maximum environment temperature + 30 °C

FRICTION LOSS CHART

(for straight pipes with 15-250 mm internal diameter and flow rates from 8 to 8330 l/min)

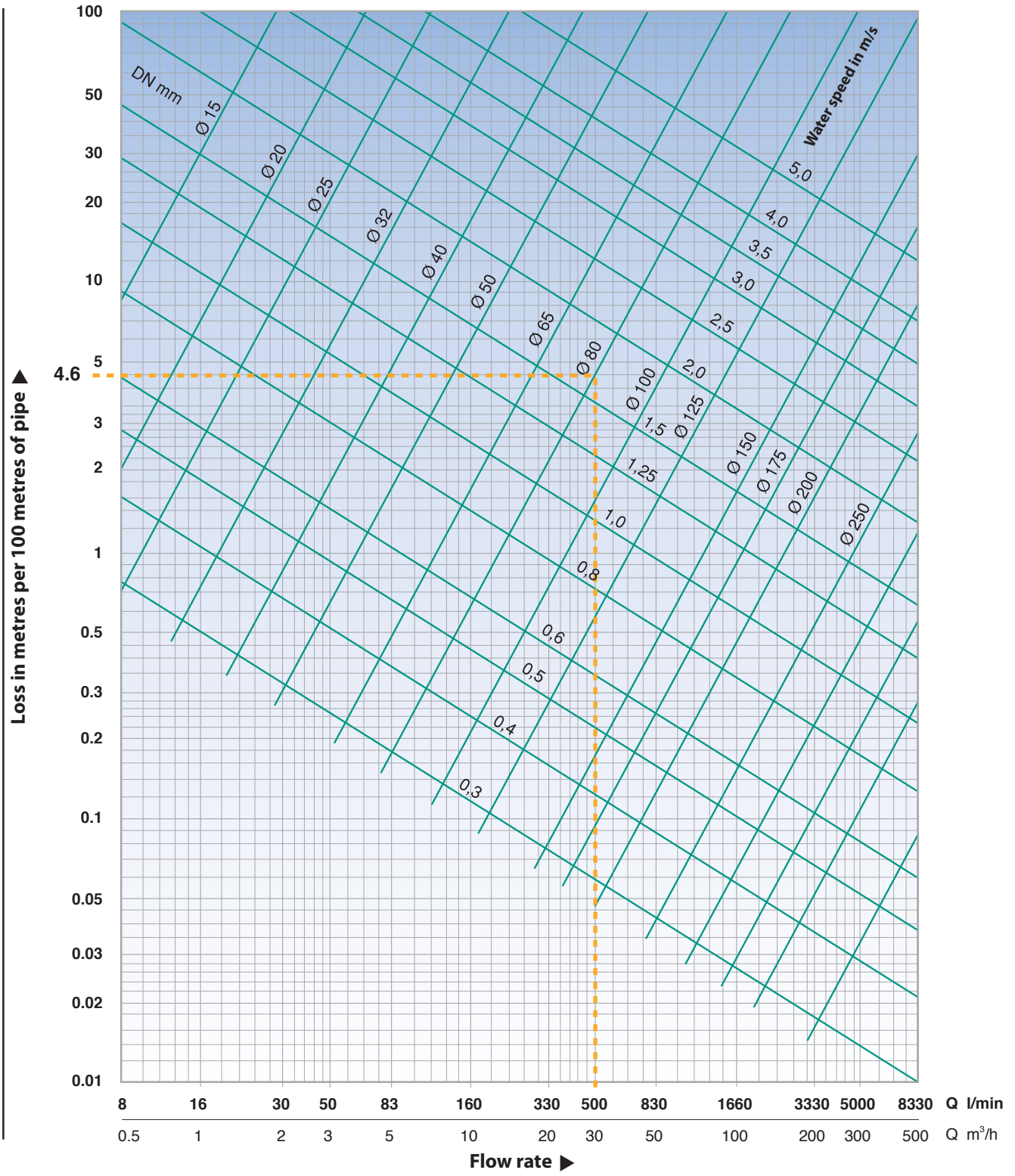

The data in the table refers to cold water and other liquids with the same kinematic viscosity and new cast iron pipes. The load losses (hv) indicated in the table must be multiplied by: **0.8** for new steel pipes, **1.25** for old, slightly rusty iron pipes, and **1.7** for old pipes where the build-up of incrustation must be taken into account.

⇒ **EXAMPLE:** Flow rate data **Q = 500 l/min**, new steel pipe Ø 80 mm, pipe length 50 m.

Find the flow rate on the horizontal axis and move vertically until you meet the DN 80 mm line.

The corresponding load losses can thus be found on the vertical axis.

hv = 4,6 m for every 100 m of pipe.

hv1 = 4,6 x 0.8 = 3.68 m/100 (steel pipe).

Considering the real length of the pipe:

hv2 = 3,68 x 50:100 = 1.84 m (for 50 m of pipe).

The flow speed is determined by considering the position of the intersection point, which is between the oblique lines with value of 1.5-2 m/sec. In the case considered that gives: **C = 1.7 metres/sec**

CONVERSION OF UNITS OF MEASUREMENT

LENGTH

millimetre	centimetre	metre	inch	foot	yard
mm	cm	m	in	ft	yd
1	0.1	0.001	0.0394	0.0033	0.0011
10	1	0.01	0.3937	0.0328	0.0109
1000	100	1	39.3701	3.2808	10.936
25.4	2.54	0.0254	1	0.0833	0.0278
304.8	30.48	0.3048	12	1	0.3333
914.4	91.44	0.9144	36	3	1

1 kilometre = 1000 metres = 0.62137 miles – 1 mile = 1609.34 metres = 1.60934 kilometres

VOLUME

cubic metre	litre	millilitre	Imperial gallon	US gallon	cubic foot
m ³	l	ml	Imp. gal.	US gal	ft ³
1	1000	1 x 10 ⁶	220	264.2	35.3147
0.001	1	1000	0.22	0.2642	0.0353
1 x 10 ⁻⁶	0.001	1	2.2 x 10 ⁻⁴	2.642 x 10 ⁻⁴	3.53 x 10 ⁻⁵
0.00455	4.546	4546	1	1.201	0.1605
0.00378	3.785	3785	0.8327	1	0.1337
0.0283	28.317	28.317	6.2288	7.4805	1

WEIGHT

kilogram	pound	hundredweight	ton	long ton	short ton
kg	lb	cwt	t	tn	sh. tn
1	2.205	0.0197	0.001	9.84 x 10 ⁻⁴	0.0011
0.454	1	0.0089	4.54 x 10 ⁻⁴	4.46 x 10 ⁻⁴	5.0 x 10 ⁻⁴
50.802	112	1	0.0508	0.05	0.056
1000	2204.6	19.684	1	0.9842	1.1023
1016	2240	20	1.0161	1	1.102
907.2	2000	17.857	0.9072	0.8929	1

VOLUMETRIC FLOW RATE

litres second	litres minute	cubic metres hour	cubic feet hour	cubic feet minute	Imp. gal. minute	US gal. minute	US barrel day (oil)
l/s	l/min	m ³ /h	ft ³ /h	ft ³ /min	Imp. gal/min	US gal/min	US barrel/g
1	60	3.6	127.133	2.1189	13.2	15.85	543.439
0.017	1	0.06	2.1189	0.0353	0.22	0.264	9.057
0.278	16.667	1	35.3147	0.5886	3.666	4.403	150.955
0.008	0.472	0.0283	1	0.0167	0.104	0.125	4.275
0.472	28.317	1.6990	60	1	6.229	7.480	256.475
0.076	4.546	0.2728	9.6326	0.1605	1	1.201	41.175
0.063	3.785	0.2271	8.0209	0.1337	0.833	1	34.286
0.002	0.110	0.0066	0.2339	0.0039	0.024	0.029	1

PRESSURE AND HEAD

Newton square metre	kiloPascal	bar	kilogram force square centimetre	pound force square inch	foot of water	metre of water	millimetre mercury	inch mercury
N/m ²	kPa	bar	kgf/cm ²	psi	ft H ₂ O	m H ₂ O	mm Hg	In Hg
1	0.001	1 x 10 ⁵	1.02 x 10 ⁵	1.45 x 10 ⁻⁴	3.35 x 10 ⁻⁴	1.02 x 10 ⁻⁴	0.0075	2.95 x 10 ⁻⁴
1000	1	0.01	1.02 x 10 ⁵	0.145	0.335	0.102	7.5	0.295
100000	100	1	1.02	14.5	33.52	10.2	750.1	29.53
98067	98.07	0.981	1	14.22	32.81	10	735.6	28.96
6895	6.895	0.069	0.0703	1	2.31	0.703	51.72	2.036
2984	2.984	0.03	0.0305	0.433	1	0.305	22.42	0.882
9789	9.789	0.098	0.1	1.42	3.28	1	73.42	2.891
133.3	0.133	0.0013	0.0014	0.019	0.045	0.014	1	0.039
3386	3.386	0.0338	0.0345	0.491	1.133	0.345	25.4	1



PEDROLLO SpA

Via Enrico Fermi 7 - 37047 San Bonifacio (VR) ITALY
tel. +39 045 6136311 - fax +39 045 7614663
sales@pedrollo.com - www.pedrollo.com

The features and specifications herein stated are in no way binding for the manufacturer. The manufacturer is free to modify the product at any time without previous notice.

Cod. 499032010